

- Flow
- Pressure
- Level
- Temperature
- pH-Value/Redox
- Conductivity
- Humidity
- Turbidity
- Density



measuring
 •
 monitoring
 •
 analysing



Production Plants of the KOBOLD Group

Hofheim, Germany



Sindelfingen, Germany



Köln, Germany



Pittsburgh, USA



Barcelona, Spain



Nyiregyháza, Hungary





Flowmeters/-switches

Variable Area-Plastic - Low Volume
Polycarbonate/brass,
Polysulfone/stainless steel
Model: KSV



Water: 0.25 1.5 l/h ... 10 80 l/h
Air: 20 80 NI/h ... 0.5 2.5 Nm³/h
t_{max} 120 °C; p_{max} 6 bar
Connection: 1/4" NPT female thread
Accuracy: ± 6 % of full scale

Variable Area - Plastic - Low Volume
Acrylic
Model: KFR



Water: 5 - 50 ml/min ... 5 - 75 l/min
Air: 0.05 - 0.5 NI/min ... 400 - 4000 NI/min
t_{max} 65 °C; p_{max} 6,5 bar
Connection: 1/8" NPT, 1" NPT female thread
Accuracy: ±2 - 5 % of full scale

Variable Area - Plastic
Trogamide, Polysulfone, PVDF
Model: KSK



Water: 1.5 - 11 l/h ... 100 - 1000 l/h
Air: 0.15 - 0.45 Nm³/h ... 20 - 105 Nm³/h
t_{max} 140 °C; p_{max} PN 10
Connection:
G 1/4...1 female, glue-in connection
Accuracy: Cl. 4 according to VDI

Variable Area - Plastic
Trogamide, Polysulfone
Model: KSM



Water: 15 - 150 l/h ... 8000 - 60000 l/h
Air: 0.8 - 5 Nm³/h ... 300 - 2500 Nm³/h
t_{max} 140 °C; p_{max} 16 bar
Connection: G 1/2...3 1/2 female/male thread
Accuracy: Cl. 4 according to VDI

Variable Area - Low Volume - Switch
Stainless steel
Model: KSR, SVN



Water: 2 - 250 ml/min
Air: 3 - 360 NI/h
t_{max} 70 °C; p_{max} 16 bar
Connection: G 1/4, 1/4" NPT female thread

Variable Area - Low Volume
Stainless steel
Model: KDF-9/KDG-9



Water: 0.02 - 0.25 l/h ... 10 - 100 l/h
Air: 2 - 20 NI/h... 300 - 3000 NI/h
t_{max} 100 °C; p_{max} 16 bar
Connection: G 1/4, 1/4" NPT female thread
Accuracy: ±3 % q_G = 50 %

Variable Area - Low Volume
Stainless steel
Model: KDF-2/KDG-2



Water: 0.025 - 2.5 l/h ... 16 - 160 l/h
Air: 0.5 - 5 NI/h ... 500 - 5000 NI/h
t_{max} 100 °C; p_{max} 16 bar
Connection: G 1/4, 1/4" NPT female thread
Accuracy: ±2,5 % q_G = 50 %

Variable Area - Glass Cone
Stainless steel, POM-C
Model: UMR, UXR



Water: 0.5 - 5 l/h ... 15 - 150 l/h
Air: 0.005 - 0.05 Nm³/h ... 0.3 - 3 Nm³/h
t_{max} 100 °C; p_{max} 16 bar
Connection: G 1/4 female thread
Accuracy: Cl. 4 according to VDI

Variable Area - Glass Cone - Thread Connection
Stainless steel, PVC
Model: URM



Water: 0.25 - 2.5 l/h ... 2500 - 25000 l/h
Air: 3.2 - 32 NI/h ... 50 - 500 Nm³/h
t_{max} 100 °C; p_{max} 20 bar
Connection: G 3/8...3 male, G 1/4...G 1 1/2 female, DIN 11851, hose connection
Accuracy: Cl. 4 according to VDI

Variable Area - Glass Cone
PVC
Model: URB



Water: 10 - 100 l/h ... 100 - 1000 l/h
Air: 0.32 - 3.2 Nm³/h ... 3.2 - 32 Nm³/h
t_{max} 65 °C; p_{max} 6 bar
Connection: G 1/2...1 1/4 male thread
Accuracy: Cl. 4 according to VDI

Variable Area - Glass Cone
Stainless steel, POM-C
Model: UVR, UTR



Water: 10 - 100 l/h ... 200 - 2000 l/h
Air: 0.1 - 1 Nm³/h ... 5 - 50 Nm³/h
t_{max} 100 °C; p_{max} 16 bar
Connection: G 3/8, G 1/2 female thread
Accuracy: Cl. 4 according to VDI

Variable Area - Glass Cone - Loose Flange
PVC, PTFE
Model: URL



Water: 1 - 10 l/h ... 250 - 2500 l/h
Air: 0.01 - 0.1 Nm³/h ... 10 - 100 Nm³/h
t_{max} 100 °C; p_{max} 6 bar
Connection: flange DN 15...40
Accuracy: Cl. 4 according to VDI





Flowmeters/-switches

Variable Area - Glass Cone

Stainless steel, PVDF, PVC

Model: V31



Water: 1.1 - 11 l/h ... 1000 - 10000 l/h
Air: 36 - 360 NI/h ... 18 - 180 Nm³/h
t_{max} 80 °C; p_{max} 15 bar
Connection: G ¼ ... 2 female,
flange DN 10 ... 65, ANSI ½" ... 2 ½"
Accuracy: Cl. 1.6/2.5 according to VDI

Variable Area - Glass Cone - Fixed Flange

Stainless steel

Model: URK



Water: 1 - 10 l/h ... 15000 - 50000 l/h
Air: 0.02 - 0.2 Nm³/h ... 50 - 500 Nm³/h
t_{max} 100 °C; p_{max} 20 bar
Connection: flange DN 15 ... 80,
ANSI ½" ... 3"
Accuracy: Cl. 4 according to VDI

Variable Area - Glass Cone - Table Mounting

POM-C

Model: URA



Water: 15 - 150 l/h
Air: 0.3 - 3 Nm³/h
t_{max} 80 °C; p_{max} 16 bar
Connection: G ¼ female thread
Accuracy: Cl. 4 according to VDI

Variable Area - Glass Cone for Compressors

Brass

Model: UTS



Air: 10 - 100 NI/h ... 0.3 - 3 Nm³/h
t_{max} 55 °C; p_{max} 3 bar
Connection:
M18 x 1.5, axial special connection
Accuracy: Cl. 4 according to VDI

Variable Area

Brass, stainless steel

Model: DSV-1



Water:
0.25 - 1.25 l/min ... 10 - 130 l/min
Air: on request
t_{max} 100 °C; p_{max} 10 bar
Connection:
G ¼ ... 1 ¼, ¼ ... 1 ¼" NPT female
Accuracy: ± 4 % of full scale

Variable Area

Brass, stainless steel

Model: DSV-3



Water:
0.25 - 1.25 l/min ... 10 - 130 l/min
Air: on request
t_{max} 100 °C; p_{max} 10 bar
Connection:
G ¼ ... 1 ¼, ¼ ... 1 ¼" NPT female
Accuracy: ± 4 % of full scale

Variable Area Switch - Low Volume

PVC

Model: SWK-13



Water: 0.2 - 0.8 l/min ... 13 - 24 l/min
Air: on request
t_{max} 60 °C; p_{max} 6 bar
Connection: G ½ female thread
Accuracy: ± 4 % of full scale

Variable Area Switch - Low Volume

Brass, stainless steel

Model: SWK-1



Water: 0.05 - 0.1 l/min ... 13 - 24 l/min
Air: on request
t_{max} 100 °C; p_{max} 250 bar
Connection: G ½ female thread
Accuracy: ± 4 % of full scale

Variable Area - Low Volume

Brass, stainless steel

Model: SWK-2



Water: 0.05 - 0.1 l/min ... 13 - 24 l/min
Air: on request
t_{max} 100 °C; p_{max} 250 bar
Connection: G ½ female thread
Accuracy: ± 4 % of full scale

Variable Area - All Metal - Low Volume

Stainless steel

Model: KDS



Water: 0.1 - 1 l/h ... 20 - 200 l/h
Air: 5 - 50 NI/h ... 600 - 6000 NI/h
t_{max} 130 °C; p_{max} PN 16/40
Connection: ¼" NPT
Option: Analogue output 4 - 20 mA
Accuracy: ± 3 % q₅ 50

Variable Area - All Metal - Low Volume

Stainless steel

Model: BGK



Water: 0.1 - 1 l/h ... 20 - 200 l/h
Air: 5 - 50 NI/h ... 600 - 6000 NI/h
t_{max} 130 °C; p_{max} PN 40 (higher on request)
Connection: DN 10, DN 15, DN 20,
ANSI ½", ¾", 1"
Option: Analogue output 4 - 20 mA
Accuracy: ± 3 % q₅ 50

Variable Area - All Metal

Stainless steel, special material on request

Model: BGN



Water: 0.5 - 5 l/h ... 13000 - 130000 l/h
Air:
0.015 - 0.15 Nm³/h ... 240 - 2400 Nm³/h
t_{max} 350 °C; p_{max} PN 40 (higher on request)
Connection:
flange DN 15 ... 150, ANSI ½" ... 6"
Options: Analogue output,
BUS-Interface, Heating coat
Accuracy: ± 1.6 - 2.2 % of full scale



Flowmeters/-switches

Variable Area - All Metal
Stainless steel, special material on request
Model: BGN-High Pressure



Water: 0.5 - 5 l/h ... 13000 - 130000 l/h
Air:
0.015 - 0.15 Nm³/h ... 240 - 2400 Nm³/h
t_{max} 350 °C; p_{max} 600 bar
Connection: flange DN 15...150,
ANSI ½"...6", thread, special connections
Options: Analogue output,
BUS-Interface, Heating coat
Accuracy: ± 1.6 - 2.2 % of full scale

Variable Area - All Metal
Brass, stainless steel
Model: DSS



Water: 0.05 - 1 l/min ... 10 - 110 l/min
t_{max} 100 °C; p_{max} 350 bar
Connection:
G ¼...1¼, ¼...1¼" NPT female thread
Accuracy: ± 5 % of full scale

Variable Area - All Metal
Brass, stainless steel
Model: SMV



Water: 0.1 - 1 l/min ... 10 - 110 l/min
t_{max} 100 °C; p_{max} 350 bar
Connection:
G ¼...1¼, ¼...1¼" NPT female thread
Accuracy: ± 5 % of full scale

Displacer All Metal
Brass, stainless steel
Model: SMO,SMW

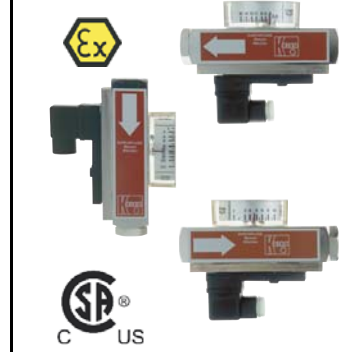

Water: 0.2 - 3 l/min ... 10 - 120 l/min
t_{max} 100 °C; p_{max} 350 bar
Connection:
G ¼...1, ¼...¾" NPT female thread
Accuracy: ± 5 % of full scale

Variable Area All Metal - Mounting Position Independent
Stainless steel, special material on request
Model: BGF

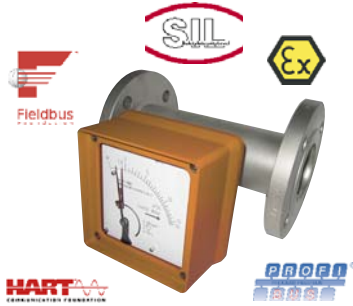

Water: 10 - 100 l/h ... 4000 - 40000 l/h
Air: 0.3 - 3 Nm³/h ... 110 - 1100 Nm³/h
t_{max} 350 °C; p_{max} PN 40
Connection:
flange DN 15...80, ANSI ½"...3"
Accuracy: ± 1.6 according to VDI

Displacer Switch - Mounting Position Independent
Brass, stainless steel
Model: SMN



Water: 1 - 100 l/min
t_{max} 100 °C; p_{max} 350 bar
Connection: 1" NPT, G 1 female thread
Accuracy: ± 5 % of full scale

Viscosity Compensated - Plastic
Polysulfone
Model: VKP



Water: 2 - 20 l/min ... 20 - 100 l/min
Oil: 1 - 18 l/min ... 10 - 75 l/min
t_{max} 120 °C; p_{max} 16 bar
Connection:
G ½, G ¾ female/male thread, G 1, 1" NPT male thread, soldered or glue-in connection
Accuracy: ± 5 % of full scale

Viscosity Compensated
Brass, stainless steel
Model: VKG



Viscosity range: 1 - 540 mm²/s
Oil: 0.1 - 0.45 l/min ... 5 - 80 l/min
t_{max} 100 °C; p_{max} 12 bar
Connection: G ¼...1, ¼...1" NPT
Accuracy: ± 4 % of full scale

Viscosity Compensated - All Metal
Brass, stainless steel
Model: VKM



Viscosity range: 1 - 540 mm²/s
Oil: 0.01 - 0.07 l/min ... 8 - 80 l/min
t_{max} 100 °C; p_{max} 350 bar
Connection: G ¼...1, ¼...1" NPT
Accuracy: ± 4 % of full scale

Viscosity Compensated - All Metal
Brass, stainless steel
Model: VKM with ADI-1



Viscosity range: 1 - 540 mm²/s
Oil: 0.01 - 0.063 l/min ... 8 - 72 l/min
t_{max} 100 °C; p_{max} 350 bar
Connection: G ¼...1, ¼...1" NPT
Accuracy: ± 4 % of full scale

Viscosity Compensated - All Metal
Brass
Model: VKA



Viscosity range: 30 - 540 mm²/s
Oil: 0.1 - 0.4 l/min ... 30 - 100 l/min
t_{max} 100 °C; p_{max} 250 bar
Connection:
G ¼...1, ½" NPT, ¾" NPT female thread
Accuracy: ± 4 % of full scale

Manifold Valves for Multiple Installation
Aluminium
Model: BVB



t_{max} 100 °C; p_{max} PN 64
Connection: G ½ female thread





Flowmeters/-switches

Paddle Switch
Brass, stainless steel
Model: PSR



Water:
2.3 - 4.7 l/min ... 47.6 - 67.2 l/min
 t_{max} 110 °C; p_{max} 100 bar
Connection:
G 1/4...1 1/2, 1/4...1 1/2" NPT female thread

Paddle Switch
Brass, stainless steel
Model: PSE



Water: 68 - 90 l/min ... 383 - 533 l/min
 t_{max} 110 °C; p_{max} 100 bar
Connection: G 1/2, 1/2" NPT male thread

Paddle Switch - Polysulfone
Polysulfone
Model: PPS



Water: 18 - 36 l/min ... 72 - 108 l/min
 t_{max} 105 °C; p_{max} 10 bar
Connection: G 1, 1" NPT male thread
Accuracy: \pm 20 % of reading

Paddle Switch - Air
Brass
Model: LPS



Air: 1 - 8 m/s
 t_{max} 85 °C; p_{max} atmospheric
Connection: connection plate

Paddle Bellow Switch
Brass, stainless steel
Model: FPS



Water:
0.17 - 0.85 m³/h ... 72.6 - 165.7 m³/h
 t_{max} 120 °C; p_{max} 30 bar
Connection: G 1/2, G 3/4 female thread, G 1, 1" NPT male thread

Paddle Bellow Switch
Brass, stainless steel, PVC
Model: DWN



Water: 1 - 5 l/min ... 900 - 3600 m³/h
 t_{max} 100 °C; p_{max} PN 16
Connection: G 3/8...2, 3/8...2" NPT female thread, flange DN 10...50, ANSI 3/8"...2", weld-on flange DN 40...500
Accuracy: \pm 3 - 5 % of full scale

Paddle Bellow Meter/Switch
Brass, Stainless steel, PVC
Model: DWU



Water: 1 - 5 l/min ... 900 - 3600 m³/h
 t_{max} 100 °C; p_{max} PN 16
Connection: G 3/8...2, 3/8...2" NPT female thread, flange DN 10...50, ANSI 3/8"...2", weld-on flange DN 40...500
Accuracy: \pm 3 - 5 % of full scale

Paddle Torsion - Meter/Switch
Aluminium-bronze, stainless steel
Model: DPT...C3



Water: 5 - 30 l/min ... 850 - 1900 l/min
 t_{max} 80 °C; p_{max} PN 40
Connection: G 3/8...3, 3/8...3" NPT female thread
Accuracy: \pm 3 % of full scale

Paddle Torsion - Meter/Switch
Aluminium-bronze, stainless steel
Model: DPT...K



Water: 5 - 30 l/min ... 850 - 1900 l/min
 t_{max} 80 °C; p_{max} PN 40
Connection: G 3/8...3, 3/8...3" NPT female thread
Accuracy: \pm 3 % of full scale

Baffle Flap Meter/Switch
Brass, stainless steel, PVC
Model: DWD



Water: 1 - 10 l/min ... 360 - 3600 m³/h
 t_{max} 120 °C; p_{max} 25 bar
Connection: G 3/8...2, 3/8...2" NPT female thread, flange DN 10...50, ANSI 3/8"...2", weld-on flange DN 40...500
Accuracy: \pm 1.5 % of full scale

Flap Meter/Switch
Steel, stainless steel, PP, PVDF, Hastelloy
Model: TSK



Water: 0.5 - 3.5 m³/h ... 200 - 1500 m³/h
 t_{max} 300 °C; p_{max} PN 40
Connection: wafer flange DN 25...500, ANSI 1"...20"
Accuracy: \pm 2 % of reading

Flow, Humidity and Temperature Hand-Held Measuring Unit
Model: HND-F115



Measuring range: 0.05...5 m/s Water; 0.55...20 m/s Air
Humidity: 0...100% rH
Temperature: -40...+120 °C, -80...250 °C
Accuracy: from \pm 0.1 %



Flowmeters/-switches

Turbine Wheel - Pulse Output
Brass, stainless steel, PPO
Model: DRS-...F5



Water: 2 - 40 l/min
 t_{max} 150°C; p_{max} 200 bar
Connection: G 1/2, G 3/4, 3/4" NPT
Accuracy: \pm 1.5 % of full scale

Turbine Wheel - Analogue Output
Brass, stainless steel, PPO
Model: DRS-...L3



Water: 2 - 40 l/min
 t_{max} 80°C; p_{max} 200 bar
Connection: G 1/2, G 3/4, 3/4" NPT
Accuracy: \pm 1.5 % of full scale

Turbine Wheel - Analogue Output
Brass, stainless steel, PPO
Model: DRS-...L4 with AUF



Water: 2 - 40 l/min
 t_{max} 80°C; p_{max} 200 bar
Connection: G 1/2, G 3/4, 3/4" NPT
Accuracy: \pm 1.5 % of full scale

Turbine Wheel - Pointer Indicator
Brass, stainless steel, PPO
Model: DRS-...Z3



Water: 2 - 40 l/min
 t_{max} 80°C; p_{max} 200 bar
Connection: G 1/2, G 3/4, 3/4" NPT
Accuracy: \pm 1.5 % of full scale

Turbine Wheel - Compact Electronic
Brass, stainless steel, PPO
Model: DRS-...C3



Water: 2 - 40 l/min
 t_{max} 80°C; p_{max} 200 bar
Connection: G 1/2, G 3/4, 3/4" NPT
Accuracy: \pm 1.5 % of full scale

Turbine Wheel - Counter
Brass, stainless steel, PPO
Model: DRS with ZED



Water: 2 - 40 l/min
 t_{max} 150°C; p_{max} 200 bar
Connection: G 1/2, G 3/4, 3/4" NPT
Accuracy: \pm 1.5 % of full scale

Turbine Wheel - Pulse Output
PVC, PVDF
Model: TUR-1



Water: 0.2 - 5 m³/h ... 2.5 - 100 m³/h
 t_{max} 70°C; p_{max} 10 bar
Connection: flange DN 25 ... 100
Accuracy: \pm 1 % of full scale

Turbine Wheel - Analogue Output
PVC, PVDF
Model: TUR-2...M



Water: 0.2 - 5 m³/h ... 2.5 - 100 m³/h
 t_{max} 70°C; p_{max} 10 bar
Connection: flange DN 25 ... 100
Accuracy: \pm 1 % of full scale

Turbine Wheel - Pointer Indicator
PVC, PVDF
Model: TUR-2...Z3



Water: 0.2 - 5 m³/h ... 2.5 - 100 m³/h
 t_{max} 70°C; p_{max} 10 bar
Connection: flange DN 25 ... 100
Accuracy: \pm 1 % of full scale

Turbine Wheel - Compact Electronics
PVC, PVDF
Model: TUR-2...C3



Water: 0.2 - 5 m³/h ... 2.5 - 100 m³/h
 t_{max} 70°C; p_{max} 10 bar
Connection: flange DN 25 ... 100
Accuracy: \pm 1 % of full scale

Turbine Wheel - Digital Display
PVC, PVDF
Model: TUR-2...K



Water: 0.2 - 5 m³/h ... 2.5 - 100 m³/h
 t_{max} 70°C; p_{max} 10 bar
Connection: flange DN 25 ... 100
Accuracy: \pm 1 % of full scale

Turbine Wheel - Pulse - Analogue Output
Aluminium-bronze, stainless steel
Model: DPE



Water: 5 - 30 l/min ... 50 - 750 l/min
 t_{max} 80°C; p_{max} PN 40
Connection: G 1/2...3, 1/2...3" NPT female thread, weld-on sleeve DN 25 ... 80
Accuracy: \pm 2.5 % of full scale





Flowmeters/-switches

Turbine Wheel - Analogue Output

Aluminium-bronze, stainless steel
Model: DPE with AUF



Water: 5 - 30 l/min ... 50 - 750 l/min
 t_{max} 80 °C; p_{max} PN 40
Connection: G 1/2...3, 1/2...3" NPT female thread, weld-on sleeve DN 25...80
Accuracy: \pm 2.5 % of full scale

Turbine Wheel - Pointer Indicator

Aluminium-bronze, stainless steel
Model: DPE-...Z3



Water: 5 - 30 l/min ... 50 - 750 l/min
 t_{max} 80 °C; p_{max} PN 40
Connection: G 1/2...3, 1/2...3" NPT female thread, weld-on sleeve DN 25...80
Accuracy: \pm 2.5 % of full scale

Turbine Wheel - Compact Electronics

Aluminium-bronze, stainless steel
Model: DPE-...C3



Water: 5 - 30 l/min ... 50 - 750 l/min
 t_{max} 80 °C; p_{max} PN 40
Connection: G 1/2...3, 1/2...3" NPT female thread, weld-on sleeve DN 25...80
Accuracy: \pm 2.5 % of full scale

Turbine Wheel - Digital Display

Aluminium-bronze, stainless steel
Model: DPE with ADI-1



Water: 5 - 30 l/min ... 50 - 750 l/min
 t_{max} 80 °C; p_{max} PN 40
Connection: G 1/2...3, 1/2...3" NPT female thread, weld-on sleeve DN 25...80
Accuracy: \pm 2.5 % of full scale

Turbine Wheel - Dosing Electronics

Aluminium-bronze, stainless steel
Model: DPE with ZED



Water: 5 - 30 l/min ... 50 - 750 l/min
 t_{max} 80 °C; p_{max} PN 40
Connection: G 1/2...3, 1/2...3" NPT female thread, weld-on sleeve DN 25...80
Accuracy: \pm 2.5 % of full scale

Turbine Wheel - Pulse-Analogue Output

Aluminium-bronze, stainless steel
Model: DRB

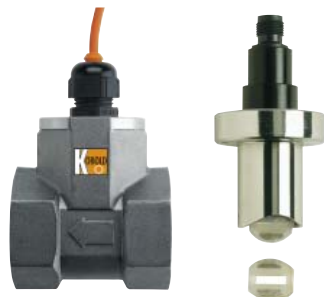

Water: 5 - 30 l/min ... 50 - 750 l/min
 t_{max} 80 °C; p_{max} 16 bar
Connection: G 1/2...3, 1/2...3" NPT female thread, weld-on sleeve DN 25...80
Accuracy: \pm 3 % of full scale

Turbine Wheel - Analogue Output

Aluminium-bronze, stainless steel
Model: DRB with AUF



Water: 5 - 30 l/min ... 50 - 750 l/min
 t_{max} 80 °C; p_{max} 16 bar
Connection: G 1/2...3, 1/2...3" NPT female thread, weld-on sleeve DN 25...80
Accuracy: \pm 3 % of full scale

Turbine Wheel - Pointer Indicator

Aluminium-bronze, stainless steel
Model: DRB-...Z3



Water: 5 - 30 l/min ... 50 - 750 l/min
 t_{max} 80 °C; p_{max} 16 bar
Connection: G 1/2...3, 1/2...3" NPT female thread, weld-on sleeve DN 25...80
Accuracy: \pm 3 % of full scale

Turbine Wheel - Compact Electronics

Aluminium-bronze, stainless steel
Model: DRB-...C3



Water: 5 - 30 l/min ... 50 - 750 l/min
 t_{max} 80 °C; p_{max} 16 bar
Connection: G 1/2...3, 1/2...3" NPT female thread, weld-on sleeve DN 25...80
Accuracy: \pm 3 % of full scale

Turbine Wheel - Digital Display

Aluminium-bronze, stainless steel
Model: DRB with ADI-1



Water: 5 - 30 l/min ... 50 - 750 l/min
 t_{max} 80 °C; p_{max} 16 bar
Connection: G 1/2...3, 1/2...3" NPT female thread, weld-on sleeve DN 25...80
Accuracy: \pm 3 % of full scale

Turbine Wheel - Dosing Electronics

Aluminium-bronze, stainless steel
Model: DRB with ZED



Water: 5 - 30 l/min ... 50 - 750 l/min
 t_{max} 80 °C; p_{max} 16 bar
Connection: G 1/2...3, 1/2...3" NPT female thread, weld-on sleeve DN 25...80
Accuracy: \pm 3 % of full scale

Turbine Wheel - Pulse Output

Stainless steel
Model: TUV



Water: 0.3 - 1.5 l/min ... 35 - 400 l/min
 t_{max} 350 °C; p_{max} 640 bar
Connection: G 1/4...1 1/2 female thread
Accuracy: \pm 1 % of reading



Flowmeters/-switches

Turbine Wheel - Pulse Output
PVDF, Stainless steel
Model: SFL



Water: 0.5 - 20 l/min
t_{max} 90 °C; p_{max} 250 bar
Connection: G 3/8
Accuracy: ± 1 % of full scale

Turbine Wheel - Counter Electronics
Stainless steel
Model: DOT



Water: 0.11 - 1.1 m³/h ... 700 - 7000 m³/h
t_{max} 240 °C; p_{max} 250 bar
Connection: G 1/2 ... 2, 1/2 ... 2" NPT,
flange DN 15 ... 500
Accuracy: ± 0.5 % (linearity)

Turbine Wheel Flowmeter/ Counter - Battery powered
Nylon, brass, stainless steel
Model: EDM



Water: 4 - 40 l/min ... 80 - 800 l/min
t_{max} 60 °C; p_{max} 100 bar
Connection: Rc 1/2 ... 2 female thread
Accuracy: ± 1.5 % of full scale

Turbine Wheel - Low Volume
Nylon, stainless steel, titanium
Model: PEL-L



Water:
0.006 - 0.1 l/min ... 10 - 500 l/min
t_{max} 135 °C; p_{max} 345 bar
Connection:
R 1/2 ... 1 1/4, within-flange DN 40/50,
glue-in connection DN 15 ... 50
Accuracy: ± 1.25 % of full scale

Turbine Wheel - Low Volume
Stainless steel, PVC, titanium
Model: PEL-M



Water:
0.006 - 0.1 l/min ... 10 - 500 l/min
t_{max} 135 °C; p_{max} 345 bar
Connection:
R 1/2 ... 1 1/4, within-flange DN 40/50,
glue-in connection DN 15 ... 50
Accuracy: ± 1.25 % of full scale

Rotating Vane - Low Volume - Pulse Output
Brass, stainless steel
Model: DPM-...F5



Water: 0.015 - 0.7 l/min ... 0.05 - 5 l/min
t_{max} 80 °C; p_{max} 16 bar
Connection:
G 1/8, G 1/4, 1/8" NPT, 1/4" NPT female thread
Accuracy: ± 1 - 2.5 % of full scale

Rotating Vane - Low Volume - Analogue Output
Brass, stainless steel
Model: DPM-...L3



Water: 0.015 - 0.7 l/min ... 0.05 - 5 l/min
t_{max} 80 °C; p_{max} 16 bar
Connection:
G 1/8, G 1/4, 1/8" NPT, 1/4" NPT female thread
Accuracy: ± 1 - 2.5 % of full scale

Rotating Vane - Low Volume - Analogue Output
Brass, stainless steel
Model: DPM-...L4 with AUF



Water: 0.015 - 0.7 l/min ... 0.05 - 5 l/min
t_{max} 80 °C; p_{max} 16 bar
Connection: G 1/8, G 1/4, 1/8" NPT, 1/4" NPT
Accuracy: ± 1 - 2.5 % of full scale

Rotating Vane - Low Volume - Pointer Indicator
Brass, stainless steel
Model: DPM-...Z3



Water: 0.015 - 0.7 l/min ... 0.05 - 5 l/min
t_{max} 80 °C; p_{max} 16 bar
Connection: G 1/8, G 1/4, 1/8" NPT, 1/4" NPT
Accuracy: ± 1 - 2.5 % of full scale

Rotating Vane - Low Volume - Compact Electronics
Brass, stainless steel
Model: DPM-...C3



Water: 0.015 - 0.7 l/min ... 0.05 - 5 l/min
t_{max} 80 °C; p_{max} 16 bar
Connection: G 1/8, G 1/4, 1/8" NPT, 1/4" NPT
Accuracy: ± 1 - 2.5 % of full scale

Rotating Vane - Low Volume - Counter
Brass, stainless steel
Model: DPM with ZED



Water: 0.015 - 0.7 l/min ... 0.05 - 5 l/min
t_{max} 80 °C; p_{max} 16 bar
Connection: G 1/8, G 1/4, 1/8" NPT, 1/4" NPT
Accuracy: ± 1 - 2.5 % of full scale

Rotating Vane - Low Volume - Pulse Output
Polypropylene
Model: DPL-...F5



Water: 0.025 - 0.5 l/min ... 1 - 25 l/min
t_{max} 70 °C; p_{max} 10 bar
Connection:
G 1/2 male thread, hose connector
Accuracy: ± 2.5 % of full scale





Flowmeters/-switches

Rotating Vane - Low Volume - Analogue Output

Polypropylene
Model: DPL-...L3



Water: 0.025 - 0.5 l/min ... 1 - 25 l/min
 t_{max} 70 °C; p_{max} 10 bar
Connection:
G 1/2 male thread, hose connector
Accuracy: \pm 2.5 % of full scale

Rotating Vane - Low Volume - Analogue Output

Polypropylene
Model: DPL-...L4 with AUF



Water: 0.025 - 0.5 l/min ... 1 - 25 l/min
 t_{max} 70 °C; p_{max} 10 bar
Connection:
G 1/2 male thread, hose connector
Accuracy: \pm 2.5 % of full scale

Rotating Vane - Low Volume - Pointer Indicator

Polypropylene
Model: DPL-...Z3



Water: 0.025 - 0.5 l/min ... 1 - 25 l/min
 t_{max} 70 °C; p_{max} 10 bar
Connection:
G 1/2 male thread, hose connector
Accuracy: \pm 2.5 % of full scale

Rotating Vane - Low Volume - Compact Electronic

Polypropylene
Model: DPL-...C3



Water: 0.025 - 0.5 l/min ... 1 - 25 l/min
 t_{max} 70 °C; p_{max} 10 bar
Connection:
G 1/2 male thread, hose connector
Accuracy: \pm 2.5 % of full scale

Rotating Vane - Low Volume - Counter

Polypropylene
Model: DPL with ZED



Water: 0.025 - 0.5 l/min ... 1 - 25 l/min
 t_{max} 70 °C; p_{max} 10 bar
Connection:
G 1/2 male thread, hose connector
Accuracy: \pm 2.5 % of full scale

Rotating Vane - Low Volume

Brass, PTFE, Rhython®
Model: KFF-1, KFG-1



Water: 15 - 100 ml/min ... 1 - 10 l/min
Air: 10 - 50 Nml/min ... 100 - 500 L_v/min
 t_{max} 50 °C; p_{max} 35 bar
Connection: hose connection 1/8" ... 1/2"
Accuracy: \pm 3 % of full scale

Rotating Vane - Low Volume

Brass, PTFE, Rhython®
Model: KFF-3, KFG-3



Water: 13 - 100 ml/min ... 0.2-5 l/min
Air: 10 - 50 Nml/min ... 2-10 L_v/min
 t_{max} 50 °C; p_{max} 35 bar
Connection: hose connection 1/8" ... 1/2"
Accuracy: \pm 3 % of full scale

Rotating Vane - Low Volume

Stainless steel
Model: DTK



Water: 0.05 - 0.6 l/min ... 1 - 12 l/min
 t_{max} 140 °C; p_{max} 30 bar
Connection: G 1/4, 1/4" NPT female thread
Accuracy: \pm 2 % of full scale

Rotating Vane - Low Volume - Pulse Output

Trogamide, Polysulfone, brass,
Polypropylene, stainless steel
Model: DF-H



Water: 0.08 - 0.5 l/min ... 40 - 160 l/min
 t_{max} 80 °C; p_{max} 100 bar
Connection: G 1/4 ... 1 1/2, 1/4 ... 1 1/2" NPT,
flange DN 15 ... 50, ANSI 1/2" ... 2"
Accuracy: \pm 2.5 % of full scale

Rotating Vane - Low Volume - Analogue Output

Trogamide, Polysulfone, brass,
Polypropylene, stainless steel
Model: DF-MA



Water: 0.08 - 0.5 l/min ... 40 - 160 l/min
 t_{max} 80 °C; p_{max} 100 bar
Connection: G 1/4 ... 1 1/2, 1/4 ... 1 1/2" NPT,
flange DN 15 ... 50, ANSI 1/2" ... 2"
Accuracy: \pm 2.5 % of full scale

Rotating Vane Switch - Low Volume

Trogamide, Polysulfone, brass,
Polypropylene, stainless steel
Model: DF-WM



Water: 0.08 - 0.5 l/min ... 40 - 160 l/min
 t_{max} 80 °C; p_{max} 100 bar
Connection: G 1/4 ... 1 1/2, 1/4 ... 1 1/2" NPT,
flange DN 15 ... 50, ANSI 1/2" ... 2"
Accuracy: \pm 2.5 % of full scale

Rotating Vane - Low Volume - Digital Display

Trogamide, Polysulfone, brass,
Polypropylene, stainless steel
Model: DF-K



Water: 0.08 - 0.5 l/min ... 40 - 160 l/min
 t_{max} 80 °C; p_{max} 100 bar
Connection: G 1/4 ... 1 1/2, 1/4 ... 1 1/2" NPT,
flange DN 15 ... 50, ANSI 1/2" ... 2"
Accuracy: \pm 2.5 % of full scale



Flowmeters/-switches

Rotating Vane - Low Volume - Counter

Trogamide, Polysulfone, Polypropylene, brass, stainless steel

Model: DF-Z



Water: 0.08 - 0.5 l/min ... 40 - 160 l/min
t_{max} 80 °C; p_{max} 100 bar
Connection: G ¼ ... 1½, ¼ ... 1½" NPT, flange DN 15 ... 50, ANSI ½" ... 2"
Accuracy: ± 2.5 % of full scale

Rotating Vane - Low Volume - Dosing Electronic

Trogamide, Polysulfone, Polypropylene, brass, stainless steel

Model: DF-D



Water: 0.08 - 0.5 l/min ... 40 - 160 l/min
t_{max} 80 °C; p_{max} 100 bar
Connection: G ¼ ... 1½, ¼ ... 1½" NPT, flange DN 15 ... 50, ANSI ½" ... 2"
Accuracy: ± 2.5 % of full scale

Rotating Vane - Pulse Output Brass

Model: DFT-11



Water: 0.2 - 2 l/min ... 3 - 60 l/min
t_{max} 80 °C; p_{max} 16 bar
Connection: G ¼ ... ¾, ¼ ... ¾" NPT
Accuracy: ± 2.5 % of full scale

Rotating Vane - Pulse Output PTFE

Model: DFT-13



Water: 0.2 - 2 l/min ... 3 - 60 l/min
t_{max} 80 °C; p_{max} 16 bar
Connection: G ¼ ... ¾, ¼ ... ¾" NPT
Accuracy: ± 2.5 % of full scale

Rotating Vane - Digital Display PTFE, brass

Model: DFT-13...K



Water: 0.2 - 2 l/min ... 3 - 60 l/min
t_{max} 80 °C; p_{max} 16 bar
Connection: G ¼ ... ¾, ¼ ... ¾" NPT
Accuracy: ± 2.5 % of full scale

Rotating Vane - Pulse - Analogue Output

POM, PVDF, brass, stainless steel
Model: DRH-...F, DRH-...L



Water: 0.2 - 0.8 l/min ... 2.5 - 50 l/min
t_{max} 80 °C; p_{max} 100 bar
Connection: G ¾, G 1, ¾" NPT, 1" NPT
Accuracy: ± 2.5 % of full scale

Rotating Vane - Analogue Output POM, PVDF, brass, stainless steel

Model: DRH with AUF



Water: 0.2 - 0.8 l/min ... 2.5 - 50 l/min
t_{max} 80 °C; p_{max} 100 bar
Connection: G ¾, G 1, ¾" NPT, 1" NPT
Accuracy: ± 2.5 % of full scale

Rotating Vane - Pointer Indicator POM, PVDF, brass, stainless steel

Model: DRH-...Z3



Water: 0.2 - 0.8 l/min ... 2.5 - 50 l/min
t_{max} 80 °C; p_{max} 100 bar
Connection: G ¾, G 1, ¾" NPT, 1" NPT
Accuracy: ± 2.5 % of full scale

Rotating Vane - Compact Electronics

POM, PVDF, brass, stainless steel
Model: DRH-...C3



Water: 0.2 - 0.8 l/min ... 2.5 - 50 l/min
t_{max} 80 °C; p_{max} 100 bar
Connection: G ¾, G 1, ¾" NPT, 1" NPT
Accuracy: ± 2.5 % of full scale

Rotating Vane - Digital Display POM, PVDF, brass, stainless steel

Model: DRH with ADI-1



Water: 0.2 - 0.8 l/min ... 2.5 - 50 l/min
t_{max} 80 °C; p_{max} 100 bar
Connection: G ¾, G 1, ¾" NPT, 1" NPT
Accuracy: ± 2.5 % of full scale

Rotating Vane - Counter POM, PVDF, brass, stainless steel

Model: DRH with ZED



Water: 0.2 - 0.8 l/min ... 2.5 - 50 l/min
t_{max} 80 °C; p_{max} 100 bar
Connection: G ¾, G 1, ¾" NPT, 1" NPT
Accuracy: ± 2.5 % of full scale

Rotating Vane - Pulse Output Polypropylene, aluminium-bronze, stainless steel

Model: DRG



Water: 0.5 - 12 l/min ... 10 - 140 l/min
t_{max} 80 °C; p_{max} 40 bar
Connection: G ½ ... 1, ½ ... 1" NPT
Accuracy: ± 3 % of full scale





Flowmeters/-switches

Rotating Vane - Analogue Output

Polypropylene, aluminium-bronze, stainless steel

Model: DRG with AUF



Water: 0.5 - 12 l/min ... 10 - 140 l/min
 t_{max} 80 °C; p_{max} 40 bar
 Connection: G 1/8... 1, 1/8... 1" NPT
 Accuracy: \pm 3 % of full scale

Rotating Vane - Pointer Indicator

Polypropylene, aluminium-bronze, stainless steel

Model: DRG-...Z3



Water: 0.5 - 12 l/min ... 10 - 140 l/min
 t_{max} 80 °C; p_{max} 40 bar
 Connection: G 1/8... 1, 1/8... 1" NPT
 Accuracy: \pm 3 % of full scale

Rotating Vane - Compact Electronics

Polypropylene, aluminium-bronze, stainless steel

Model: DRG-...C3



Water: 0.5 - 12 l/min ... 10 - 140 l/min
 t_{max} 80 °C; p_{max} 40 bar
 Connection: G 1/8... 1, 1/8... 1" NPT
 Accuracy: \pm 3 % of full scale

Rotating Vane - Digital Display

Polypropylene, aluminium-bronze, stainless steel

Model: DRG with ADI-1



Water: 0.5 - 12 l/min ... 10 - 140 l/min
 t_{max} 80 °C; p_{max} 40 bar
 Connection: G 1/8... 1, 1/8... 1" NPT
 Accuracy: \pm 3 % of full scale

Rotating Vane - Dosing Electronics

Polypropylene, aluminium-bronze, stainless steel

Model: DRG with ZED



Water: 0.5 - 12 l/min ... 10 - 140 l/min
 t_{max} 80 °C; p_{max} 40 bar
 Connection: G 1/8... 1, 1/8... 1" NPT
 Accuracy: \pm 3 % of full scale

Rotating Vane - Pulse Output

Brass

Model: DOW



Water: 1 - 70 l/min
 t_{max} 90 °C; p_{max} 10 bar
 Connection: G 3/4 male thread, 3/4" NPT
 Accuracy: \pm 1.5 % of reading

Rotating Vane - Insertion Version

Stainless steel

Model: DOR



Water: 0.36 - 6300 l/s ... 0.3 - 10 m/s
 t_{max} 200 °C; p_{max} 80 bar
 Connection: G 1 1/2, G 2, 1 1/2" NPT, 2" NPT
 for tubes \varnothing 40 ... 2500 mm
 Accuracy: \pm 1.5 % (linearity)

Dual-Ring Piston - Pendulum - Low Volume

Stainless steel

Model: LFM



Water: 0.005 - 0.25 l/min
 t_{max} 70 °C; p_{max} 100 bar
 Connection: G 1/8, Swagelok 6 mm
 Accuracy: \pm 2.5 % of reading

Ring Piston Counter - Pulse Output

Brass

Model: DRZ...F



Viscosity range: 5 - 100 mm²/s
 Oil: 6 - 420 l/h
 t_{max} 80 °C; p_{max} 40 bar
 Connection: G 1/8, G 1/4, 1/8" NPT, 1/4" NPT
 Accuracy: \pm 1 % of reading

Ring Piston Counter - Analogue Output

Brass

Model: DRZ with AUF



Viscosity range: 5 - 100 mm²/s
 Oil: 6 - 420 l/h
 t_{max} 80 °C; p_{max} 40 bar
 Connection: G 1/8, G 1/4, 1/8" NPT, 1/4" NPT
 Accuracy: \pm 1 % of reading

Ring Piston Counter - Compact Electronics

Brass

Model: DRZ-...C3



Viscosity range: 5 - 100 mm²/s
 Oil: 6 - 420 l/h
 t_{max} 80 °C; p_{max} 40 bar
 Connection: G 1/8, G 1/4, 1/8" NPT, 1/4" NPT
 Accuracy: \pm 1 % of reading

Ring Piston Counter

Aluminium, stainless steel

Model: DRT



Viscosity range: up to 1 000 000 mPas
 Oil: 10 - 500 l/h ... 700 - 20 000 l/h
 t_{max} 150 °C; p_{max} 350 bar
 Connection: G 1/2... 2, 1/2... 2" NPT, flange DN 15... 50, Tri-Clamp
 Accuracy: \pm 0.5 - 1 % of reading



Flowmeters/-switches

Oval Gear - Pulse Output
POM, aluminium
Model: OVZ-...I4



Viscosity range: 10 - 800 mm²/s
Oil: 0.3 - 8 l/min ... 1.6 - 40 l/min
t_{max} 80 °C; p_{max} 40 bar
Connection: G 1/4 ... 3/4, 1/4 ... 3/4" NPT
Accuracy: ± 2.5 % of full scale

Oval Gear - Analogue Output
POM, aluminium
Model: OVZ-...L4 with AUF



Viscosity range: 10 - 800 mm²/s
Oil: 0.3 - 8 l/min ... 1.6 - 40 l/min
t_{max} 80 °C; p_{max} 40 bar
Connection: G 1/4 ... 3/4, 1/4 ... 3/4" NPT
Accuracy: ± 2.5 % of full scale

Oval Gear - Pointer Indicator
POM, aluminium
Model: OVZ-...Z3



Viscosity range: 10 - 800 mm²/s
Oil: 0.3 - 8 l/min ... 1.6 - 40 l/min
t_{max} 80 °C; p_{max} 40 bar
Connection: G 1/4 ... 3/4, 1/4 ... 3/4" NPT
Accuracy: ± 2.5 % of full scale

Oval Gear - Compact Electronics
POM, aluminium
Model: OVZ-...C3



Viscosity range: 10 - 800 mm²/s
Oil: 0.3 - 8 l/min ... 1.6 - 40 l/min
t_{max} 80 °C; p_{max} 40 bar
Connection: G 1/4 ... 3/4, 1/4 ... 3/4" NPT
Accuracy: ± 2.5 % of full scale

Oval Gear - Dosing Electronics
POM, aluminium
Model: OVZ with ZED



Viscosity range: 10 - 800 mm²/s
Oil: 0.3 - 8 l/min ... 1.6 - 40 l/min
t_{max} 80 °C; p_{max} 40 bar
Connection: G 1/4 ... 3/4, 1/4 ... 3/4" NPT
Accuracy: ± 2.5 % of full scale

Oval Gear - Counter - Pulse Output
Aluminium, stainless steel, cast iron
Model: DOM-...F4



Viscosity range: 0 - 1 000 000 mPas
Oil: 0.5 - 36 l/h ... 150 - 2500 l/min
t_{max} 120 °C; p_{max} 400 bar
Connection: G 1/2 ... 4 female thread
Accuracy: ± 0.2 - 1 % of reading

Oval Gear - Counter - Pulse Output
Aluminium, stainless steel, cast iron
Model: DOM-...LCD



Viscosity range: 0 - 1 000 000 mPas
Oil: 0.5 - 36 l/h ... 150 - 2500 l/min
t_{max} 120 °C; p_{max} 400 bar
Connection: G 1/2 ... 4 female thread
Accuracy: ± 0.2 - 1 % of reading

Oval Gear - Counter - Mechanical
Aluminium, stainless steel, cast iron
Model: DOM-...mech



Viscosity range: 0 - 1 000 000 mPas
Oil: 0.5 - 36 l/h ... 150 - 2500 l/min
t_{max} 120 °C; p_{max} 400 bar
Connection: G 1/2 ... 4 female thread
Accuracy: ± 0.2 - 1 % of reading

Oval Gear With Air Eliminator
Aluminium, stainless steel, cast iron
Model: DOM with ZAL



Viscosity range: 0 - 1 000 000 mPas
Oil: 10 - 150 l/min ... 150 - 2500 l/min
t_{max} 70 °C; p_{max} 10 bar
Connection: flange DN 20...50,
ANSI 3/4" ... 2"
Accuracy: ± 0.2 - 1 % of reading

Dosing Unit - Rotating Vane
Brass
Model: DOB



Water: 1 - 70 l/min
t_{max} 80 °C; p_{max} 10 bar
Connection: G 3/4 male thread,
3/4" NPT male thread
Accuracy: ± 0.5 % of reading

Dosing Unit - Mechanical
Aluminium, stainless steel, cast iron
Model: DOL



Viscosity range: 0 - 1 000 000 mPas
Oil: 0.5 - 36 l/h ... 150 - 2500 l/min
t_{max} 120 °C; p_{max} 400 bar
Connection: G 1/2 ... 4 female thread
Accuracy: ± 0.2 - 1 % of reading

Dosing Unit - Oval Gear For Additives
Stainless steel
Model: DOP



Water: 0.01 - 1 l/min ... 0.25 - 10 l/min
t_{max} 100 °C; p_{max} 20 bar
Connection: 3/8" NPT
Accuracy: ± 0.5 % of reading





Flowmeters/-switches

Screw Spindle - Meter

Cast iron, stainless steel

Model: OMG



Viscosity range: 1 - 5000 mm²/s
Oil: 0.1 - 10 l/min ... 50 - 5000 l/min
t_{max} 200 °C; p_{max} 420 bar
Connection:
G ½... 6 female thread, flange DN 15... 150
Accuracy: ± 0.3 % of reading

Screw Spindle - Dosing Electronics

Cast iron, stainless steel

Model: OMG with ADI-1



Viscosity range: 1 - 5000 mm²/s
Oil: 0.1 - 10 l/min ... 50 - 5000 l/min
t_{max} 200 °C; p_{max} 420 bar
Connection:
G ½... 6 female thread, flange DN 15... 150
Accuracy: ± 0.3 % of reading

Screw Spindle - Counter

Cast iron, stainless steel

Model: OMG with ZED



Viscosity range: 1 - 5000 mm²/s
Oil: 0.1 - 10 l/min ... 50 - 5000 l/min
t_{max} 200 °C; p_{max} 420 bar
Connection:
G ½... 6 female thread, flange DN 15... 150
Accuracy: ± 0.3 % of reading

Screw Spindle - Meter

Aluminium

Model: OME



Viscosity range: 1 - 5000 mm²/s
Oil: 0.2 - 10 l/min ... 2 - 100 l/min
t_{max} 100 °C; p_{max} 40 bar
Connection:
G ½... 1 female thread, flange DN 15... 25
Accuracy: ± 0.3 % of reading

Screw Spindle - Dosing Electronics

Aluminium

Model: OME with ADI-1



Viscosity range: 1 - 5000 mm²/s
Oil: 0.2 - 10 l/min ... 2 - 100 l/min
t_{max} 100 °C; p_{max} 40 bar
Connection:
G ½... 1 female, flange DN 15... 25
Accuracy: ± 0.3 % of reading

Screw Spindle - Counter

Aluminium

Model: OME with ZED



Viscosity range: 1 - 5000 mm²/s
Oil: 0.2 - 10 l/min ... 2 - 100 l/min
t_{max} 100 °C; p_{max} 40 bar
Connection:
G ½... 1 female, flange DN 15... 25
Accuracy: ± 0.3 % of reading

Gear Wheel - Meter

Cast iron, stainless steel

Model: DZR



Viscosity range: 20 - 5000 mm²/s
Oil: 0.008 - 2 l/min ... 3 - 700 l/min
t_{max} 150 °C; p_{max} 400 bar
Connection: G ¾... 1 female thread
Accuracy: ± 0.3 - 1 % of reading

Gear Wheel - Dosing Electronics

Cast iron, stainless steel

Model: DZR with ADI-1



Viscosity range: 20 - 5000 mm²/s
Oil: 0.008 - 2 l/min ... 3 - 700 l/min
t_{max} 150 °C; p_{max} 400 bar
Connection: G ¾... 1 female thread
Accuracy: ± 0.3 - 1 % of reading

Gear Wheel - Counter

Cast iron, stainless steel

Model: DZR with ZED



Viscosity range: 20 - 5000 mm²/s
Oil: 0.008 - 2 l/min ... 3 - 700 l/min
t_{max} 150 °C; p_{max} 400 bar
Connection: G ¾... 1 female thread
Accuracy: ± 0.3 - 1 % of reading

Gear Wheel - Meter

Aluminium

Model: KZA



Viscosity range: 20 - 4000 mm²/s
Oil: 0.02 - 4 l/min ... 1 - 200 l/min
t_{max} 80 °C; p_{max} 160 bar
Connection: G ¼... 1 female thread
Accuracy: ± 0.3 - 3 % of reading

Gear Wheel - Dosing Electronics

Aluminium

Model: KZA with ADI-1



Viscosity range: 20 - 4000 mm²/s
Oil: 0.02 - 4 l/min ... 1 - 200 l/min
t_{max} 80 °C; p_{max} 160 bar
Connection: G ¼... 1 female thread
Accuracy: ± 0.3 - 3 % of reading

Gear Wheel - Counter

Aluminium

Model: KZA with ZED



Viscosity range: 20 - 4000 mm²/s
Oil: 0.02 - 4 l/min ... 1 - 200 l/min
t_{max} 80 °C; p_{max} 160 bar
Connection: G ¼... 1 female thread
Accuracy: ± 0.3 - 3 % of reading



Flowmeters/-switches

Calorimetric Indicator/Switch
Stainless steel
Model: KAL-D



Water: 0.04 - 2 m/s
 t_{max} 80°C; p_{max} 40 bar
Connection:
G 1/4 ... 1 1/2, 1/4 ... 3/4" NPT, M12, Tri-Clamp

Calorimetric Indicator/Switch
Stainless steel
Model: KAL-K



Water: 0.04 - 2 m/s
 t_{max} 120°C; p_{max} 100 bar
Connection:
G 1/4 ... 1 1/2, 1/4 ... 3/4" NPT, M12, Tri-Clamp

Calorimetric Meter/Switch
Stainless steel
Model: KAL-A(K)



Water: 0.04 - 2 m/s
 t_{max} 120°C; p_{max} 100 bar
Connection:
G 1/4 ... 1 1/2, 1/4 ... 3/4" NPT, M12, Tri-Clamp
Accuracy: \pm 10 % of full scale

Calorimetric Indicator/Switch
Brass, stainless steel
Model: KAL, KAL-E



Water: 0.04 - 2 m/s
 t_{max} 120°C; p_{max} 100 bar
Connection:
G 1/4 ... 1 1/2, 1/4 ... 3/4" NPT, M12, Tri-Clamp

Calorimetric Flowmeter/Switch
Stainless steel
Model: DVK



Air: 1 - 10 Nl/min ... 600 - 12000 Nl/h
 t_{max} 50°C; p_{max} 15 bar
Connection: G 1/4 ... 2
Accuracy: 5 % of full scale

Calorimetric Indicator/Switch
Brass
Model: KAL-L



Air: 1 - 20 m/s
 t_{max} 120°C; p_{max} 8 bar
Connection:
G 1/2, Rp 1/2, M18, flange, smooth shaft
Accuracy: 10 % of reading

Mass - Flowmeter - Thermal
Aluminium, stainless steel
Model: DMW-A/B

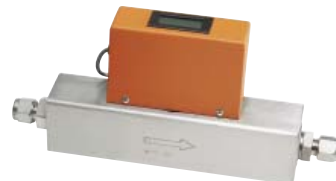

Air: 5 - 100 Nml/min ... 380 - 7 500 Nl/min
 t_{max} 50°C; p_{max} 10 bar
Connection: G 1/4 ... 1 female thread
Accuracy: 3 % of full scale

Mass - Flowmeter/Controller - Thermal
Aluminium, stainless steel
Model: DMW-C/D



Air: 5 - 100 Nml/min ... 50 - 1000 Nl/min
 t_{max} 50°C; p_{max} 10 bar
Connection: G 1/4 ... 1/2 female thread
Accuracy: 3 % of full scale

Mass - Flowmeter - Thermal
Nylon, stainless steel
Model: MAS



Air: 0 - 10 Nml/min ... 0 - 500 Nml/min
 t_{max} 50°C; p_{max} 35 bar
Connection:
1/4" NPT female thread, Swagelok
Accuracy: \pm 1.5 % of full scale

Mass - Meter/Controller - Thermal
Nylon, stainless steel
Model: MFC



Air: 0 - 10 Nml/min ... 0 - 50 Nl/min
 t_{max} 50°C; p_{max} 35 bar
Connection:
1/4" NPT female thread, Swagelok
Accuracy: \pm 1.5 % of full scale

Mass - Meter/Controller - Thermal
Stainless steel
Model: DMS



Air: 0 - 10 Nml/min ... 0 - 200 Nl/min
 t_{max} 50°C; p_{max} 35 bar
Connection: 1/4 ... 1/2" NPT female thread,
clamp connection
Accuracy: \pm 1 % of full scale

Mass - Flowmeter - Thermal
Stainless steel
Model: KMT-1/-2/-3



Air: 0.5 - 200 Nm/s
 t_{max} 80°C; p_{max} 16 bar
Connection: R 1/2 ... 2 ball valve
Accuracy: \pm 2.5 % of reading
 \pm 0.15 % of full scale





Flowmeters/-switches

Mass - Flowmeter - Thermal
Stainless steel

Model: KMT-4



Air: 0.2 - 200 Nm/s
 t_{max} 80 °C; p_{max} 16 bar
 Connection: R 1/2" male for insertion (DN65...DN300)
 Accuracy: $\pm 2.5\%$ of reading $\pm 0.5\%$ of full scale

Mass - Flowmeter - Thermal
Stainless steel

Model: KES-1/3/4



Air: 0 - 4.7 m/s ... 0 - 94 m/s
 t_{max} 175 °C; p_{max} 16 bar
 Connection: 1/4 ... 8" NPT, compression fitting with 1/2" NPT, 1" NPT
 Accuracy: $\pm 1.0\%$ of full scale $\pm 0.5\%$ of reading

Coriolis Mass
Stainless steel

Model: TME/UMC-3

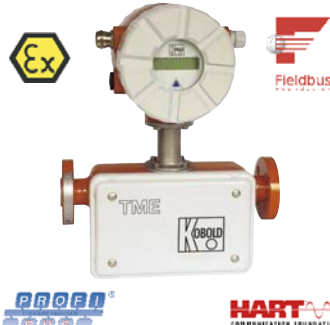

Water: 0 - 60 kg/h ... 0 - 60 000 kg/h
 t_{max} 180 °C; p_{max} PN 40
 Connection: flange DN 10 ... 80, ANSI 1/2" ... 3"
 Accuracy: $\pm 0.15\%$ of reading

Coriolis Mass
Stainless steel, Hastelloy

Model: TMU/UMC-3

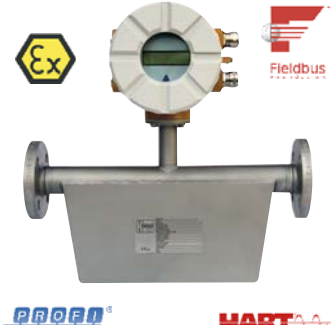

Water: 0 - 60 kg/h ... 0 - 2 200 000 kg/h
 t_{max} 260 °C;
 p_{max} PN 40 (up to 750 bar on request)
 Connection: flange DN 10 ... 300, ANSI 1/2" ... 12"
 Accuracy: $\pm 0.1\%$ of reading

Coriolis Mass with Heating
Stainless steel, Hastelloy

Model: TMU-...AC

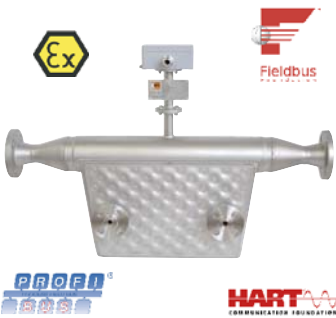

Water: 0 - 60 kg/h ... 0 - 1 900 000 kg/h
 t_{max} 260 °C; p_{max} PN 40
 Connection: flange DN 10 ... 300, ANSI 1/2" ... 12"
 Accuracy: $\pm 0.1\%$ of reading

Coriolis Mass
Stainless steel, Hastelloy, tantalum

Model: TM/UMC-3



Water: 0 - 0.8 kg/h ... 0 - 65 000 kg/h
 t_{max} 260 °C; p_{max} PN 40
 Connection: 1/4 ... 1/2" NPT, flange DN 10 ... 100, ANSI 1/2" ... 4"
 Accuracy: $\pm 0.1\%$ of reading

Coriolis Mass
Stainless steel, Hastelloy, tantalum

Model: TMR/UMC-3



Viscosity range: 0.3 - 50 000 mPas
 Water: 0 - 120 kg/h ... 0 - 120 000 kg/h
 t_{max} 260 °C; p_{max} PN 40
 Connection: flange DN 20 ... 100, ANSI 3/4" ... 4"
 Accuracy: $\pm 0.1 - 0.15\%$ of reading

Coriolis Mass
Stainless steel

Model: TME/UMC-4



Water: 0 - 60 kg/h ... 0 - 60 000 kg/h
 t_{max} 180 °C; p_{max} PN 40
 Connection: flange DN 10 ... 80, ANSI 1/2" ... 3"
 Accuracy: $\pm 0.15\%$ of reading

Coriolis Mass
Stainless steel, Hastelloy

Model: TMU/UMC-4



Water: 0 - 60 kg/h ... 0 - 2 200 000 kg/h
 t_{max} 260 °C;
 p_{max} PN 40 (up to 750 bar on request)
 Connection: flange DN 10 ... 300, ANSI 1/2" ... 12"
 Accuracy: $\pm 0.1\%$ of reading

Orifice Plate - Differential Pressure
Steel, stainless steel, Hastelloy C, titanium, Monel, tantalum

Model : KPL



Measuring span: 1:10
 Connection: DN 50...1600,
 t_{max} 560 °C; p_{max} PN 100

Venturi Nozzle - Differential Pressure
Aluminium-bronze, stainless steel

Model: RCD-...Z



Water: 0.5 - 3.3l/min ... 300 - 2350l/min
 Air: 0.5 - 5.35 Nm³/h ... 300 - 2750 Nm³/h
 t_{max} 100 °C; p_{max} PN 40
 Connection: G 1/2 ... 3, 1/2 ... 3" NPT female
 Accuracy: $\pm 3\%$ of full scale

Venturi Nozzle - Differential Pressure
Aluminium-bronze, stainless steel

Model: RCD-...C3



Water: 0.5 - 3.3l/min ... 300 - 2350l/min
 Air: 0.5 - 5.35 Nm³/h ... 300 - 2750 Nm³/h
 t_{max} 100 °C; p_{max} PN 40
 Connection: G 1/2 ... 3, 1/2 ... 3" NPT female
 Accuracy: $\pm 3\%$ of full scale





Flowmeters/-switches

Orifice Differential Pressure Flowmeter

Aluminium-bronze, stainless steel
Model: RCD-...K



Water: 0.5 - 3.3 l/min ... 300 - 2350 l/min
Air: 0.5 - 5.35 Nm³/h ... 300 - 2750 Nm³/h
t_{max} 100 °C; p_{max} PN 40
Connection: G 1/2 ... 3, 1/2 ... 3" NPT female
Accuracy: ± 3 % of full scale

Electromagnetic - Analogue Output

PPS/Stainless steel, PVDF/Hastelloy
Model: MIK-...L4 with AUF

High Quality - Low Cost



Water: 10 - 500 ml/min ... 40 - 800 l/min
t_{max} 80 °C; p_{max} 10 bar
Connection: G 1/2 ... 2 3/4 male thread
Accuracy: ± 2 % of full scale

Electromagnetic - Pulse Output
PPS/Stainless steel, PVDF/Hastelloy
Model: MIK-...F3

High Quality - Low Cost



Water: 10 - 500 ml/min ... 40 - 800 l/min
t_{max} 80 °C; p_{max} 10 bar
Connection: G 1/2 ... 2 3/4 male thread
Accuracy: ± 2 % of full scale

Electromagnetic - Compact Electronics
PPS/Stainless steel, PVDF/Hastelloy
Model: MIK-...C3

High Quality - Low Cost



Water: 10 - 500 ml/min ... 40 - 800 l/min
t_{max} 80 °C; p_{max} 10 bar
Connection: G 1/2 ... 2 3/4 male thread
Accuracy: ± 2 % of full scale

Electromagnetic - Counter
PPS/Stainless steel, PVDF/Hastelloy
Model: MIK-...E

High Quality - Low Cost



Water: 10 - 500 ml/min ... 40 - 800 l/min
t_{max} 80 °C; p_{max} 10 bar
Connection: G 1/2 ... 2 3/4 male thread
Accuracy: ± 2 % of full scale

Electromagnetic - Dosing Electronics
PPS/Stainless steel, PVDF/Hastelloy
Model: MIK-...G

High Quality - Low Cost



Water: 10 - 500 ml/min ... 40 - 800 l/min
t_{max} 80 °C; p_{max} 10 bar
Connection: G 1/2 ... 2 3/4 male thread
Accuracy: ± 2 % of full scale

Electromagnetic - Insertion
Stainless steel, PTFE- or PFA-lining
Model: PIT



Water: 0 - 5 m/s or 0 - 10 m/s
t_{max} 150 °C; p_{max} PN 40
Connection:
flange DN 40...80, ANSI 2" ... 3",
for pipelines DN 150 ... 1200
Accuracy: ±1.5% of reading

Electromagnetic - Insertion with Installation-/Extracting Device
Stainless steel, PTFE- or PFA-lining
Model: PIT-U



Water: 0 - 10 m/s
t_{max} 100 °C; p_{max} PN 40
Connection:
flange DN 40...80, ANSI 2" ... 3"
Accuracy:
± 1.5 % of reading ± 0.5 % of full scale

Electromagnetic Meter
Lining: hard rubber, soft rubber, Wa-
gunit, PTFE, PVDF
Model: DMH



Water: 0 - 10 m/s
t_{max} 150 °C; p_{max} PN 40
Connection:
flange DN 10 ... 1200, ANSI 1/2" ... 48"
Option: Sensor in stainless steel, wafer
type, sanitary connections
Accuracy: ± 0.3 % of reading

Ultrasonic Meter for Flow Measurement in Open Channels
PP
Model: NUS-4



Measuring range (water): depends on
dimensions of canal/weir
t_{max} 90 °C; p_{max} 3 bar abs
Connection:
G 1 1/2, G 2, 1 1/2" NPT, 2" NPT male, DN 80,
DN 125, DN 150, ANSI 3", 5", 6"
Analogue output
Accuracy: depends on dimensions of
canal/weir

Vortex - Switch
PPS/Brass, PPS/Stainless steel
Model: DVZ-...S3

High Quality - Low Cost



Water: 0.5 - 4.5 l/min ... 10 - 100 l/min
t_{max} 80 °C; p_{max} 10 bar
Connection: G 1/4 ... 1, 1/4 ... 1" NPT
Accuracy: ± 2.5 % of full scale

Vortex - Analogue Output
PPS/Brass, PPS/Stainless steel
Model: DVZ-...L

High Quality - Low Cost



Water: 0.5 - 4.5 l/min ... 10 - 100 l/min
t_{max} 80 °C; p_{max} 10 bar
Connection: G 1/4 ... 1, 1/4 ... 1" NPT
Accuracy: ± 2.5 % of full scale





Flowmeters/ Switches

Vortex - Analogue Output
PPS/Brass, PPS/Stainless steel
Model: DVZ-...L4 with AUF

High Quality - Low Cost



Water: 0.5 - 4.5 l/min ... 10 - 100 l/min
 t_{max} 80°C; p_{max} 10 bar
Connection: G 1/4 ... 1, 1/4 ... 1" NPT
Accuracy: ± 2.5 % of full scale

Vortex - Pulse Output
PPS/Brass, PPS/Stainless steel
Model: DVZ-...F3

High Quality - Low Cost



Water: 0.5 - 4.5 l/min ... 10 - 100 l/min
 t_{max} 80°C; p_{max} 10 bar
Connection: G 1/4 ... 1, 1/4 ... 1" NPT
Accuracy: ± 2.5 % of full scale

Vortex - Compact Electronic
PPS/Brass, PPS/Stainless steel
Model: DVZ-...C3

High Quality - Low Cost



Water: 0.5 - 4.5 l/min ... 10 - 100 l/min
 t_{max} 80°C; p_{max} 10 bar
Connection: G 1/4 ... 1, 1/4 ... 1" NPT
Accuracy: ± 2.5 % of full scale

Vortex - Counter
PPS/Brass, PPS/Stainless steel
Model: DVZ-...E

High Quality - Low Cost



Water: 0.5 - 4.5 l/min ... 10 - 100 l/min
 t_{max} 80°C; p_{max} 10 bar
Connection: G 1/4 ... 1, 1/4 ... 1" NPT
Accuracy: ± 2.5 % of full scale

Vortex - Dosing Electronic
PPS/Brass, PPS/Stainless steel
Model: DVZ-...G

High Quality - Low Cost



Water: 0.5 - 4.5 l/min ... 10 - 100 l/min
 t_{max} 80°C; p_{max} 10 bar
Connection: G 1/4 ... 1, 1/4 ... 1" NPT
Accuracy: ± 2.5 % of full scale

Vortex - Meter
Stainless steel
Model: DVH



Water: 0.2 - 5 ... 32 - 970 m³/h
Air:
3 - 28 Nm³/h ... 3057 - 280187 Nm³/h
 t_{max} 400°C; p_{max} PN 100
Connection: DN 15 ... 200, ANSI 1/2" ... 8"
Option: integrated temperature and pressure sensor, wafer type
Accuracy: ± 0.7 % of reading (water)
 ± 1 % of reading (gas/steam)

Vortex - Meter
Stainless steel
Model: DVE



Water: 5.2 - 157 ... 284 - 8537 m³/h
Air: 889 - 1463 Nm³/h ... 26915 - 2467081 Nm³/h
 t_{max} 400°C; p_{max} 100 bar
Connection: 2" NPT, DN 50, ANSI 2", mountable in NW80 ... NW600
Option: integrated temperature and pressure sensor, installation/removal device
Accuracy: ± 1.2 % of reading (water)
 ± 1.5 % of reading (gas/steam)

Oscillation - Meter/Switch
Stainless steel
Model: DOG-1



Air: 0.2 - 20 Nm³/h ... 35 - 3500 Nm³/h
Pressure drop: max. 50 mbar
 t_{max} 120°C (for EX 60°C); p_{max} PN 40
Connection:
Flange DN 25 ... 200, ANSI 1" ... 8"
Accuracy: ± 1.5 % of reading

Oscillation - Meter/Switch
Stainless steel
Model: DOG-2

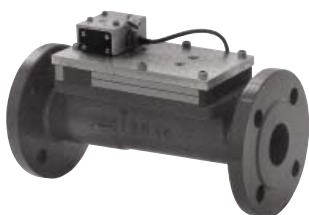

Water:
0.075 - 3.75 m³/h ... 19.6 - 980 m³/h
 t_{max} 120°C; p_{max} PN 40
Connection:
flange DN 25 ... 200, ANSI 1" ... 8"
Accuracy: ± 0.5 % of reading

Oscillation - Meter/Switch
Transducer/Transmitter
Model: DOG-1/-2... Electronic options



Input: frequency
Analogue output
Limit contacts, sensor supply, counter, flow computer

Ultrasonic - Switch
Brass, stainless steel
Model: DUK-...S3

High Quality - Low Cost



Water: 0.08 - 20 l/min ... 2.5 - 630 l/min
 t_{max} 90°C; p_{max} 10 bar
Connection: G 1/2 ... 3 female thread
Accuracy: ± 1.5 % of full scale

Ultrasonic - Analogue Output
Brass, stainless steel
Model: DUK-...L4 with AUF

High Quality - Low Cost



Water: 0.08 - 20 l/min ... 2.5 - 630 l/min
 t_{max} 90°C; p_{max} 10 bar
Connection: G 1/2 ... 3 female thread
Accuracy: ± 1.5 % of full scale



Ultrasonic - Pulse Output

Brass, stainless steel

Model: DUK-...F3

High Quality - Low Cost



Water: 0.08 - 20 l/min ... 2.5 - 630 l/min
 t_{max} 90 °C; p_{max} 10 bar
 Connection: G 1/2 ... 3 female thread
 Accuracy: \pm 1.5 % of full scale

Ultrasonic - Compact Electronics-

Brass, stainless steel

Model: DUK-...C3

High Quality - Low Cost



Water: 0.08 - 20 l/min ... 2.5 - 630 l/min
 t_{max} 90 °C; p_{max} 10 bar
 Connection: G 1/2 ... 3 female thread
 Accuracy: \pm 1.5 % of full scale

Ultrasonic - Counter/Dosing

Brass, stainless steel

Model: DUK-...E, G

High Quality - Low Cost



Water: 0.08 - 20 l/min ... 2.5 - 630 l/min
 t_{max} 90 °C; p_{max} 10 bar
 Connection: G 1/2 ... 3 female thread
 Accuracy: \pm 1.5 % of full scale

Ultrasonic - Digital Display

Brass, stainless steel

Model: DUK-...K

High Quality - Low Cost



Water: 0.08 - 20 l/min ... 2.5 - 630 l/min
 t_{max} 90 °C; p_{max} 10 bar
 Connection: G 1/2 ... 3 female thread
 Accuracy: \pm 1.5 % of full scale

Flow Regulators

Brass, stainless steel

Model: REG

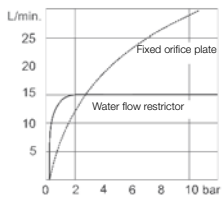

Viscosity range: 1 - 30 mm²/s
 Flow rates: 0.5 - 40 l/min
 t_{max} 300 °C; p_{max} 200 bar
 Connection: G 1/2, G 3/4, 3/4" NPT

Flow Regulators

Brass, stainless steel

Model: REG



Viscosity range: 1 - 30 mm²/s
 Flow rates: 0.5 - 40 l/min
 t_{max} 300 °C; p_{max} 200 bar
 Connection: G 1/2, G 3/4, 3/4" NPT

Flow Regulators - Multiple Element

Brass, stainless steel

Model: REG-8



Viscosity range: 1 - 30 mm²/s
 Flow rates: 1 - 280 l/min
 t_{max} 300 °C; p_{max} 200 bar
 Connection: flange DN 20...50

Flow Regulators - Multiple Element

Brass, stainless steel

Model: REG-9



Viscosity range: 1 - 30 mm²/s
 Flow rates: 1 - 280 l/min
 t_{max} 300 °C; p_{max} 200 bar
 Connection: G 1 1/2 ... G 2 1/2

Flow Indicator with Rotor

Brass, stainless steel

Model: DAA, DAH



Water: 0.4 - 4 l/min ... 8 - 100 l/min
 t_{max} 100 °C; p_{max} 16 bar
 Connection: G 1/4 ... 1 1/2, 1/4 ... 1 1/2" NPT female

Flow Indicator with Rotor

Grey cast iron, cast steel, stainless steel

Model: DAR-1



t_{max} 260 °C; p_{max} 40 bar
 Connection: G 1/4 ... 2, 1/4 ... 2" NPT female

Flow Indicator with Rotor

Grey cast iron, cast steel, stainless steel

Model: DAR-2



t_{max} 260 °C; p_{max} 40 bar
 Connection: flange DN 15 ... 200, ANSI 1/2" ... 8"

Flow Indicator with Rotating Vane

Brass, stainless steel

Model: DAF-1



Water: 0.03 - 0.1 l/min ... 5 - 150 l/min
 t_{max} 110 °C; p_{max} 16 bar
 Connection: G 1/8 ... 1 1/2, 1/8 ... 1 1/2" NPT female





Flow Indicators

Flow Indicator with Rotor
Brass, stainless steel
Model: DAF-2



Water: 0.03 - 0.1 l/min ... 5 - 150 l/min
 t_{max} 110 °C; p_{max} 16 bar
Connection:
flange DN 15 ... 50, ANSI 1/2" ... 2"

Flow Indicator with Rotor
Brass
Model: DKF



Water: 0.14 - 2 l/min ... 1.8 - 83 l/min
 t_{max} 120 °C; p_{max} 6 bar
Connection: G 1/8" ... 1, 1/4" ... 1" NPT female

Flow Indicator with Rotor
Brass, stainless steel, POM
Model: DIH



Water: 0.2 - 0.5 l/min ... 1 - 50 l/min
 t_{max} 80 °C; p_{max} 16 bar
Connection:
G 3/8, G 1 female thread, 3/8" NPT, 1" NPT

Flow Indicator with Rotor
PP, aluminium-bronze, stainless steel
Model: DIG



Water: 0.5 - 12 l/min ... 3 - 80 l/min
 t_{max} 80 °C; p_{max} 16 bar
Connection: G 1/2" ... 1, 1/4" ... 1" NPT female

Flow Indicator with Flap
Grey cast iron, cast steel, stainless steel
Model: DAK-1



t_{max} 280 °C; p_{max} 40 bar
Connection: G 1/4" ... 2, 1/2" ... 2" NPT female

Flow Indicator with Flap
Grey cast iron, cast steel, stainless steel
Model: DAK-2



t_{max} 280 °C; p_{max} 40 bar
Connection:
flange DN 15 ... 200, ANSI 1/2" ... 8"

Flow Indicator with Flap
Red cast iron
Model: DAZ



Water: 2.1 - 17 l/min ... 2.1 - 24 l/min
 t_{max} 200 °C; p_{max} 16 bar
Connection: G 1/2" ... 1 female thread

Flow Indicator with Ball
Bronze
Model: DAB



t_{max} 100 °C; p_{max} 6 bar
Connection: G 3/4" ... 3 female thread

Flow Indicator with Ball
Brass
Model: DKB



Water:
0.05 - 15 l/min ... 0.14 - 105 l/min
 t_{max} 120 °C; p_{max} 6 bar
Connection: G 1/8" ... 1, 1/4" ... 1" NPT female

Flow Indicator with Drip Tube
Grey cast iron, cast steel, stainless steel
Model: DAT-1



t_{max} 280 °C; p_{max} 40 bar
Connection: G 1/4" ... 2, 1/2" ... 2" NPT female

Flow Indicator with Drip Tube
Grey cast iron, cast steel, stainless steel
Model: DAT-2



t_{max} 280 °C; p_{max} 40 bar
Connection:
flange DN 15 ... 200, ANSI 1/2" ... 8"

Flow Indicator - Sight Glass
Stainless Steel, PVC
Model: UFJ



Connection: G 1/4" ... G 2 female
 t_{max} 100 °C; p_{max} 20 bar





Pressure Measurement

Bourdon Tube Pressure Gauges
Brass, stainless steel

Model: MAN-R,-Q



Measuring range:
-1 ... 0 bar ... 0 ... +1000 bar
Housing: Ø 63, 100, 160 mm
Overload protected: 1.15- 1.3 times
Connection: G ¼, G ½ male thread
Accuracy: Cl. 1.0; 1.6

All Stainless Steel Bourdon Tube Pressure Gauges
Stainless steel

Model: MAN-R



Measuring range:
-1 ... 0 bar ... 0 ... +1000 bar
Housing: Ø 63, 100, 160 mm
Overload protected: 1.15- 1.3 times
Connection: G ¼, G ½ male thread
Accuracy: Cl. 1.0; 1.6

All Stainless Steel Bourdon Tube Pressure Gauges for Exceptional Safety
Stainless steel

Model: MAN-N...S



Measuring range:
-1 ... 0 bar ... 0 ... +1600 bar
Housing: Ø 63, 100, 150 mm
Overload protected: 1.15- 1.5 times
Connection:
G ¼, G ½, ½" NPT, ¼" NPT male thread
Accuracy: Cl. 1.0; 1.6

Bourdon Tube - Refrigeration
Brass, stainless steel

Model: MAN-T



Measuring range:
-1 ... +9 bar ... -1 ... +40 bar
Housing: Ø 63, 80, 100 mm
Overload protected: 1.0 times
Connection: 7/16-20 UNF, G ¼ male
Accuracy: Cl. 1.0; 1.6

Capsule Element Pressure Gauges
Brass, stainless steel

Model: MAN-K



Measuring range:
-10 ... 0 bar ... 0 ... +600 bar
Housing: Ø 63, 80, 100, 160 mm
Overload protected: 0.9- 10 times
Connection: G ¼, G ½ male thread
Accuracy: Cl. 1.6

Diaphragm Pressure Gauges
Stainless steel

Model: MAN-P



Measuring range:
-16 ... 0 mbar; 0 ... +40 bar
Housing: Ø 100, 160 mm
Overload protected: 1.15- 1.3 times
Connection: G ½ male thread, open flange
Accuracy: Cl. 1.6

All Stainless Steel Pressure Transducer
Stainless steel

Model: MAN-ZF



Measuring range:
-1 ... 0 bar ... 0 ... +600 bar
Housing: Ø 100 mm
Overload protected: 0.9- 1.0 times
Connection: G ½ male thread
Accuracy: Cl. 1.0

Pressure Gauges Digital with Ceramic Sensor Element, Battery Powered
St. steel/PA glass fibre reinforced

Model: MAN-SD



Measuring range:
-1 ... 0 bar ... 0 ... +1600 bar
Display: LC-Display
Overload protected: 1.3-3 times
Connection:
G ¼, G ½, ¼" NPT, ½" NPT male
Accuracy: Cl. 0.5

Pressure Gauges Digital with Ceramic Sensor Element
Stainless steel/PA glass fibre reinforced

Model: MAN-LD



Measuring range:
-1 ... 0 bar ... 0 ... +1600 bar
Display: LC-Display
Overload protected: 1.3- 3 times
Connection:
G ¼, G ½, ¼" NPT, ½" NPT male thread
analogue output 4-20mA
power supply: 24 V_{DC}
Accuracy: Cl. 0.5

Pressure Gauges with Ceramic/-Thin Film Cell
Stainless steel

Model: PDC



Measuring range:
0 ... +2 bar ... 0 ... +700 bar
Display: 2 x 4½-digit LCD, illuminated
Overload protected:
2 times - max. 1000 bar
Connection: G ¼, ¼" NPT male thread
Accuracy: ± 0.5 % of full scale ... ±1 Digit

Pressure Gauges Digital with Ceramic Sensor Element
Stainless steel/PA glass fibre reinforced

Model: MAN-SF26



Measuring range:
-1 ... 0 bar ... 0 ... +1600 bar
Display: 4-digit LED
Overload protected: 2 times
Connection:
G ¼, G ½, ¼" NPT, ½" NPT male thread
Accuracy: Cl. 0.5

U-Pipe Pressure Gauges
Glass

Model: PUM



Measuring range:
0 ... ±25 mbar ... 0 ... ±150 mbar
Scale division: 2 mm
Hose connection: Ø 7 mm
Accuracy: ± 0.2 mbar



Pressure Measurement

Differential Pressure Gauge Digital with Ceramic Sensor Element

St. steel/PA glass fibre reinforced
Model: MAN-BF26



Measuring range:
-1 ... 0 bar ... 0 ... +1 600 bar
Display: 4-digit LED
Overload protected: 2 times
Connection:
G ¼, G ½, ¼" NPT, ½" NPT male thread
Accuracy: Cl. 0.5

Differential Pressure Gauge Digital with Ceramic Sensor Element

St. steel/PA glass fibre reinforced
Model: MAN-BF20



Measuring range:
-1 ... 0 bar ... 0 ... +1 600 bar
Display: 4-digit LED
Overload protected: 2 times
Connection:
G ¼, G ½, ¼" NPT, ½" NPT male thread
Accuracy: Cl. 0.5

Differential Pressure Gauge Digital with Ceramic Sensor Element

St. steel/PA glass fibre reinforced
Model: MAN-BF28V



Measuring range:
-1 ... 0 bar ... 0 ... +1 600 bar
Display: 4-digit LED
Overload protected: 2 times
Connection:
G ¼, G ½, ¼" NPT, ½" NPT male thread
Accuracy: Cl. 0.5

Differential Pressure Gauge with double diaphragm

Stainless steel
Model: MAN-UF, -UH



Measuring range:
0 ... +100 mbar ... 0 ... +25 bar
Static pressure on both sides: 200 bar
Housing: Ø 100 mm, 150 mm
Connection:
G ½, ½" NPT male, ¼" NPT female
Accuracy: Cl. 1.6

Differential Pressure Gauge with Bourdon Tube

Brass, stainless steel
Model: MAN-DF, -DG



Measuring range:
0.1 ... +0.3 bar ... 0 ... +600 bar
Overload protected:
1.3 times - (short time)
Connection: G ½ male thread
Accuracy: Cl. 1.6

Differential Pressure Gauge with Bourdon Tube

Aluminium, steel
Model: MAN-DG12R



Measuring range:
0 ... +1 bar ... 0 ... +60 bar
Housing: Ø 160 mm
Overload protected:
1.3 times - (short time)
Connection: G ½ male thread
Accuracy: Cl. 1.6

Differential Pressure Gauge with Diaphragm

Aluminium
Model: MAN-Dx2A



Measuring range:
0 ... +25 mbar ... 0 ... +25 bar
Housing: Ø 100, 160 mm
Connection: G ¼ female thread
Accuracy: Cl. 1.6

Differential Pressure Gauge with Diaphragm

Stainless steel
Model: MAN-DF2G, -DG2G



Measuring range:
0 ... +60 mbar ... 0 ... +40 bar
special versions up to PN 400
Housing: Ø 100, 160 mm
Connection: G ½ female thread
Accuracy: Cl. 1.6

Hand-Held Pressure Measuring Device for Differential Pressure for 2 External Sensors

Model: HND-P215



Measuring range: -2.5 mbar ... +400 bar depending on sensor
Option: logger, alarm, control function
Accuracy: ± 0.1 % of full scale

Hand-Held Pressure Measuring Device for Differential Pressure for 2 Integrated Sensors

Model: HND-P126, -P236



Measuring range: -100 ... +2000 mbar
Option: logger, alarm
Accuracy: ± 0.2 % of full scale

Differential Pressure Sensor - Thin Film

Model: PMP



Measuring range: 0 ... +50 mbar
Power supply: 24 V_{AC/DC}, 110 V_{AC}, 230 V_{AC}
Display: 4-digit LED
Connection: hose connection 6 x 8 mm

Differential Pressure Transmitter

St. steel, Monel, tantalum, Hastelloy

Model: PAD

High Quality - Low Cost



HART COMMUNICATION FOUNDATION

Measuring range:
+0.75 mbar ... +413.70 bar
Power supply: 18 - 45 V_{DC}
Connection: ¼" NPT, ½" NPT
Accuracy: ± 0.075 % of measuring span



Pressure Measurement

Differential Pressure Transmitter with Diaphragm Seal

St. steel, Monel, Tantalum, Hastelloy, PTFE
Model: PAD-...N

High Quality - Low Cost



HART
COMMUNICATOR FOUNDATION

Measuring range:
0 ... +250 mbar ... 0 ... +206.80 bar
 t_{max} 200 °C
Connection: flange-, thread-, clamp on-, and in-line diaphragm seal (nominal size 15 ... 100)
Accuracy: $\pm 0.075\%$ of calibrated span + influence of diaphragm seal

Pressure Transmitter for Harsh Conditions

Brass
Model: PNK

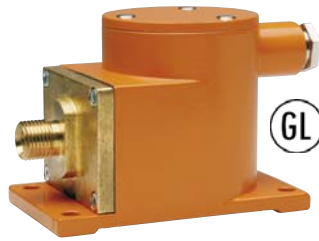

Measuring range:
-1 ... 0 bar ... 0 ... +100 bar
Overload protection: 1.6 times
Connection: M16x1.5 with sealing cone, Adapter: R 1/4, R 1/2, 1/2" NPT male thread
Accuracy: $\pm 1\%$ of full scale

Test Pressure Gauge with Bourdon Tube

Aluminium, brass, stainless steel
Model: MAN-F



Measuring range:
-0.6 ... 0 bar ... 0 ... +2500 bar
Housing: \varnothing 160, 250 mm
Overload protected: 1.0 times - (calm)
Connection: G 1/2 male thread
Accuracy: Cl. 0.25; 0.6

Pressure Gauge with Membrane Diaphragm Seal

Stainless steel
Model: MAN-RF...D



Measuring range:
-1 ... +3 bar ... 0 ... +40 bar
Housing: \varnothing 100 mm
Overload protected: 1.3 times
Connection: flange \varnothing 85 mm
Accuracy: Cl. 1.6

Diaphragm, Capsule, and Inline Diaphragm Seals for Pressure Gauges

Stainless steel, special material on request
Model: DRM



Measuring range:
0 ... +1 bar ... 0 ... +1600 bar
Filling:
glycerine, paraffin- and silicone oil
diverse thread and flange connection, Tri-Clamp, DIN 11851, SMS- and IDF-Norm
Accuracy: Cl. 1.6

All Stainless Steel Bourdon Tube Pressure Gauge with Membrane Diaphragm

Stainless steel
Model: MAN-RD...DRM-600



Measuring range:
0 ... +6 bar ... 0 ... +1600 bar
Housing: \varnothing 63 mm
Connection:
G / NPT-thread; M 20x1.5; M 48x3
Accuracy: Cl. 1.6

Contact Pressure Gauges with Membrane Diaphragm Seal

Stainless steel
Model: MAN-RF...M...DRM-601



Measuring range:
0 ... +6 bar ... 0 ... +1600 bar
Housing: \varnothing 100 mm
Connection: G 1/2 ... 1 1/2 male thread
Accuracy: Cl. 1.6

Pressure Gauge with Diaphragm Seal DIN 11851 and Cool. Element

Stainless steel
Model: MAN-RF...MZB-711...DRM-602



Measuring range:
0 ... +1 bar ... 0 ... +40 bar
Housing: \varnothing 100 mm
Connection: DIN 11851 DN 20... 100
Accuracy: Cl. 1.6

All Stainless Steel Pressure Gauge with Membrane Diaphragm

Stainless steel
Model: MAN-RF...M1...DRM-628



Measuring range:
0 ... +1 bar ... 0 ... +40 bar
Housing: \varnothing 100, 160 mm
Connection: flange DN 25... 100
Accuracy: Cl. 1.6

All Stainless Steel Pressure Gauge with Membrane Diaphragm

Stainless steel
Model: MAN-RF...M1...DRM-620



Measuring range:
0 ... +1 bar ... 0 ... +40 bar
Housing: \varnothing 100, 160 mm
Connection: flange DN 25 ... 100
Accuracy: Cl. 1.6

All Stainless Steel Pressure Gauge with In-Line Diaphragm

Stainless steel
Model: MAN-RF...M21...DRM-502



Measuring range:
+1.6 ... +40 bar ... +2.5 ... +40 bar
Connection: Tri-Clamp 1/2" ... 2", hygienic connection ISO DN 15... 50
Accuracy: Cl. 1.6

Contact Pressure Gauge with Membrane Diaphragm Seal DIN 11851

Stainless steel
Model: MAN-RF...M21...DRM-602



Measuring range:
0 ... +1 bar ... 0 ... +40 bar
Connection:
Union nut DIN 11851 DN 20... 100
Accuracy: Cl. 1.6



Pressure Measurement

Pressure Gauge with Membrane Diaphragm Seal, DIN 11851

Stainless steel

Model: MAN-RF...DRM-603



Measuring range:
0 ... +1 bar ... 0 ... +40 bar
Connection:
Union nut DIN 11851 DN 25... 100
Accuracy: Cl. 1.6

Pressure Gauge with Diaphragm Seal Clamp Connection

Stainless steel

Model: MAN-RF...DRM-613



Measuring range:
0 ... +2,5 bar ... 0 ... +10 bar
Housing: Ø 100 mm
Connection: Tri-Clamp 1" ... 3"
Accuracy: Cl. 1.6

Pressure Gauges with Diaphragm for PCB Manufacture

PPH

Model: MAN...



Measuring range:
0 ... +1 bar ... 0 ... +25 bar
Connection: G 3/4 male thread
Accuracy: Cl. 1.6

Digital Pressure Gauges with Diaphragm Seals for Homogenizing Machines

Stainless steel

Model: MAN-SD...DRM-189



Measuring range:
0 ... +100 bar ... 0 ... +1 000 bar
Membrane: flush mounted
Connection: for block flange
Accuracy: Cl. 1.6

Pressure Sensor with Diaphragm Seals for Homogenizing Machines

Stainless steel

Model: SEN...DRM-189...AUF



Measuring range:
0 ... +100 bar ... 0 ... +1 000 bar
Membrane: flush mounted
 t_{max} 100 °C
Connection: for block flange
Accuracy: Cl. 1.0

Digital Pressure Gauges with Diaphragm Seals for Homogenizing Machines

Stainless steel

Model: MAN-SF...DRM-189



Measuring range:
0 ... +100 bar ... 0 ... +1 000 bar
Housing: Ø 100 mm
Membrane: flush mounted
Display: 4-digit, green LED display
 t_{max} 100 °C
Connection: for block flange
Accuracy: Cl. 1.0

Digital Pressure Gauge with Membrane Diaphragm Seal PVC

PVC

Model: MAN-SD...DRM-630



Measuring range:
0 ... +1,6 bar ... 0 ... +10 bar
Housing: Ø 74 mm
Connection: G 1/4, G 1/2, 1/2" NPT female
Accuracy: Cl. 1.0

Pressure Sensor with Membrane Diaphragm Seal PP

Polypropylene

Model: SEN...DRM-631



Measuring range:
0 ... +1,6 bar ... 0 ... +10 bar
Connection: G 1/4, G 1/2, 1/2" NPT female
Accuracy: Cl. 1.6

Pressure Gauge with Membrane Diaphragm Seal

PVDF

Model: MAN-RD...DRM-632



Measuring range:
0 ... +1,6 bar ... 0 ... +16 bar
Housing: Ø 63 mm
Connection: G 1/4, G 1/2, 1/2" NPT female
Accuracy: Cl. 1.6

Pressure Sensor with Diaphragm Seal and AUF

Stainless steel

Model: SEN...DRM-600



Measuring range:
0 ... +6 bar ... 0 ... +600 bar
 t_{max} 70 °C
Connection:
G 1/2... G 1 1/2 male, stainless steel
Accuracy: Cl. 1.0

Pressure Sensor with Plug-on Display and Process Assembly

Brass, Stainless steel

Model: SEN-86 with AUF, KUG-S



Measuring range:
-1 ... 0 bar ... 0 ... +600 bar
Overload protected: 1.5-2 times
Connection: G 1/2 male thread
Accuracy: Cl. 0.5; 1.0

Pressure Sensor with Ceramic Cell

Stainless steel

Model: PDA



Measuring range:
-1 ... 0 bar ... 0 ... +400 bar
Display: 3-digit LED
Connection: G 1/4, G 1/2, 1/4" NPT, 1/2" NPT male thread
Accuracy: ± 0.5 - 1 % of full scale



Pressure Measurement

Pressure Transmitter
Stainless Steel, Hastelloy-C, Tantalum
Model: PAS

High Quality - Low Cost



Measuring range: -1 ... +600 bar
Power supply: 11.9 - 45 V_{DC}
Connection: 1/4" NPT female, 1/2" NPT female
Accuracy: ±0.075 % of calibrated span

Pressure Transmitter with Diaphragm Seal
St. steel, Monel, Tantalum, Hastelloy, PTFE
Model: PAS-...N

High Quality - Low Cost



Measuring range:
0 ... +250 mbar ... 0 ... +600 bar
t_{max} 200 °C
Connection: Thread or with flange (nominal size 15 ... 100)
Accuracy: ±0.075% of calibrated span + influence of diaphragm seal

Pressure Transmitter with Diaphragm Seal
St. steel, Monel, Tantalum, Hastelloy, PTFE
Model: PAS-...N

High Quality - Low Cost



Measuring range:
0 ... +250 mbar ... 0 ... +600 bar
t_{max} 350 °C
Connection: Thread or flange (nominal size 15 ... 100)
Accuracy: ±0.075% of calibrated span + influence of diaphragm seal

Pressure Sensor with Ceramic Cell and Plug-On Display AUF
Stainless Steel
Model: SEN-86 with AUF



Measuring range:
-1 ... 0 bar ... 0 ... +600 bar
Display: 4-digit LED
Overload protected: 1.5 - 2 times
Connection: G 1/2, 1/2" NPT male thread
Accuracy: Cl. 0.5; 1.0

Pressure Sensor with Ceramic Cell and Plug-On Display AUF
Stainless Steel
Model: SEN-87 with AUF



Measuring range:
-1 ... 0 bar ... 0 ... +600 bar
Display: 4-digit LED
Overload protected: 1.5 - 2 times
Connection: G 1/4, 1/4" NPT male thread
Accuracy: Cl. 0.5; 1.0

Pressure Sensor with Ceramic Cell
Stainless Steel
Model: SEN-96



Measuring range:
0 ... 1 bar ... 0 ... +600 bar
Overload protected: 1,3 - 5 times
Connection:
G 1/4, 1/2, 1/4" NPT, 1/2" NPT male thread
Accuracy: ±≤ 1 % of full scale

Pressure Sensor with Ceramic Cell
Stainless Steel
Model: SEN-98/-99



Measuring range:
-1 ... 0 bar ... 0 ... +600 bar (rel)
0 ... 1 bar ... 0 ... +25 bar (abs)
Overload protected: 1,3 - 5 times
Connection:
G 1/4, 1/2, 1/4" NPT, 1/2" NPT male thread
Accuracy: ≤0,25...0,5% of span

Pressure Sensor Compact Piezoresistive
Stainless Steel
Model: SEN-3297



Measuring range:
0 ... +1 bar ... 0 ... +6 bar
Membrane: internal
Overload protected: 2 times
Connection:
G 1/4, 1/2, 1/4" NPT, 1/2" NPT male thread
Accuracy: Cl. 1.0

Pressure Sensor Compact Thin Film
Stainless Steel
Model: SEN-3397



Measuring range:
0 ... +10 bar ... 0 ... +600 bar
Membrane: internal
Overload protected: 2 times
Connection:
G 1/4, 1/2, 1/4" NPT, 1/2" NPT male thread
Accuracy: Cl. 1.0

Pressure Sensor Industrial Piezoresistive
Stainless Steel
Model: SEN-3276,-3277



Measuring range:
-1 ... 0 bar ... 0 ... +25 bar
Membrane: internal
Overload protected: 2 - 3.5 times
Connection:
G 1/4, 1/2, 1/4" NPT, 1/2" NPT male thread
Accuracy: ± 0.25 - 0.5 % of full scale

Pressure Sensor Industrial Piezoresistive - Flush Mounted
Stainless Steel
Model: SEN-3251,-3252



Measuring range:
-1 ... 0 bar ... 0 ... +25 bar
Membrane: flush mounted
Overload protected: 2 - 3.5 times
Connection: G 1/2, G 1 male thread
Accuracy: ± 0.25 - 0.5 % of full scale

Press. Sensor Industrial Thin Film
Stainless steel
Model: SEN-3376,-3377



Measuring range:
0 ... +40 bar ... 0 ... +1000 bar
Membrane: internal
Overload protected: 1.5 - 3 times
Connection:
G 1/4, 1/2, 1/4" NPT, 1/2" NPT male thread
Accuracy: Cl. 0.25; 0.5



Pressure Measurement/ Monitoring

Pressure Sensor Precision Piezoresistive/Thin Film

Stainless steel
Model: SEN-3290, -3390



Measuring range:
-0.25 ... 0 bar ... 0 ... +1000 bar
Membrane: internal
Overload protected: 1.5-3.5 times
Connection: G 1/2 male thread
Accuracy: ± 0.1 % of full scale

Pressure Sensor Piezoresistive/ Thin Film - Flush Mounted

Stainless steel
Model: SEN-3344, -3386



Measuring range:
0 ... +40 bar ... 0 ... +600 bar
Membrane: flush mounted
Overload protected: 2 times
Connection: G 1/2 male thread
Accuracy: Cl. 0.25; 0.5

Pressure Hand-Held Unit for External Sensors

Model: HND-P210, -215



Measuring range:
-1.99 ... +2.5 mbar ... 0 ... +400 bar
(sensor dependent)
Option: logger, alarm, control function
Accuracy: ± 0.1 % of full scale

Differential Pressure Hand-Held Unit with 2 Integrated Sensors

Model: HND-P121, -123, 126



Measuring range:
-1 ... +25 mbar ... -10.0 ... +2000 mbar
Option: logger, alarm, control function
Accuracy: ± 0.2 % of full scale

Pressure Hand-Held Unit with 1 Integrated Sensor

Model: HND-P129, -239



Measuring range: 0 ... +1300 mbar
Option: logger, alarm, control function
Accuracy: ± 0.2 % of full scale

Pressure Switch with Ceramic Cell

Stainless Steel
Model: PDD



Measuring range:
-1 ... 0 bar ... 0 ... +400 bar
Display: 3-digit LED
Overload protected: 1.5-2 times
Connection:
G 1/4, G 1/2, 1/4" NPT, 1/2" NPT male thread
Accuracy: ± 0.5 - 1 % of full scale

Electronic Pressure Switch - Thin Film/Ceramic

Stainless Steel
Model: PSC



Measuring range:
-1 ... +2 bar ... 0 ... +700 bar
Display: 4-digit LED
Connection:
G 1/4, G 1/2, 1/4" NPT, 1/2" NPT male thread
Accuracy: ± 1 % of full scale ... ± 1 Digit

Pressure Switch with Hall Sensor

Brass, aluminium
Model: PDL-0/-1



Switching range:
-0.9 ... -0.05 bar ... +30 ... +600 bar
Switching function: N/O/N/C
Connection: G 1/4, 1/4" NPT male thread
Repeatability: < 1 % of full scale

Pressure Switch - mechanical

Stainless Steel
Model: SCH-27



Switching range:
0,7 ... 6 mbar ... 8 ... 160 bar
Switching function: micro switch
Connection: 1/2" NPT female, 1/4" NPT female, 1/2" NPT male, G 1/2 male
Repeatability: < 1% of switching point

Differential Pressure Switch - mechanical

Stainless Steel
Model: SCH-28



Switching range:
0,1 ... 1 bar ... 0,2 ... 10 bar
Switching function: micro switch
Connection: 1/2" NPT female, 1/4" NPT female, 1/2" NPT male, G 1/2 male
Repeatability: < 1% of switching point

Pressure Gauges Accessories

Brass, steel, stainless steel
Model: MZB



Shut off cocks and valves,
syphons, trottle and overpressure
protection equipment, adapters

Sandwich Plug-On Display

Model: AUF



Input: 4-20 mA loop powered
Option: Open-Collector
No additional power supply required



Level Switches

Float Magnet Switch

Brass, stainless steel, PVC, PPH, PVDF

Model: M



Density: 0.5 kg/dm³
t_max 150°C; p_max 100 bar
Connection: thread /NPT, flange DIN/ANSI

Float Magnet Switch

Brass, stainless steel, PVC, PP

Model: MS



Density: from 0.6 kg/dm³
t_max 150°C; p_max 100 bar
Connection: G 3/8 male thread

Float Bypass Switch

Aluminium, stainless steel

Model: NBA/NBE



Density: 0.65 kg/dm³
t_max 90°C; p_max 10 bar
Connection: G 3/8 female, R 1/2 male

Plastic Level Switch

Polypropylene, PVDF

Model: NKP



Density: 0.6 kg/dm³
t_max 100°C; p_max 10 bar

Float Switch

Stainless steel

Model: RFS



Density: 0.7 kg/dm³
t_max 120°C; p_max 5 bar
Connection: 1/2" NPT male thread

Float Switch

Brass, stainless steel

Model: NV



Density: 0.7 kg/dm³
t_max 110°C; p_max 16 bar
Connection: G 3/4 male, M27 x 1,5 male

Float Switch

Polyethylene, Polypropylene

Model: NSP-S



Density: 0.9 kg/dm³
t_max 85°C; p_max 1 bar
Connection: Cable

Float Switch

Polypropylene

Model: NAB



Density: 0.5 ... 1.15 kg/dm³
t_max 85°C; p_max 5 bar
Connection: Cable

Float Switch

Polypropylene

Model: NSM



Density: 0.6 kg/dm³
t_max 95°C; p_max 3 bar
Connection: Cable

Float Switch

Polypropylene, Hypalon

Model: NEC



Density: 0.7 ... 1.4 kg/dm³
t_max 95°C; p_max 5,5 bar
Connection: Cable

Float Switch

PTFE

Model: NST



Density: 0.79 kg/dm³
t_max 150°C; p_max 1 bar
Connection: Cable

Float Switch

Stainless steel

Model: NSE



Density: 0.8 kg/dm³
t_max 150°C; p_max 15 bar
Connection: G 1/2 male thread

Dual Magnet Float Switch

Stainless steel

Model: NGS

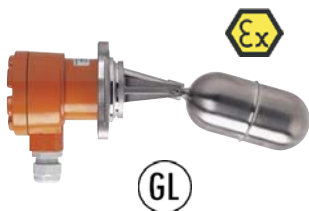

Density: 0.7 kg/dm³
t_max 250°C; p_max 25 bar
Connection: Square box flange, DIN-flange, DN80/100, BSP 2", 2" NPT

Conductive Switch

Stainless steel, Hastelloy, Titanium, Coating: Polypropylene, PTFE

Model: NES



t_max 150°C; p_max 30 bar
Connection: G 1/2, G 1 1/2 male thread

Conductive Suspended Electrodes

Stainless steel, Hastelloy, Titanium, Neoprene, PVC

Model: NEH



t_max 150°C; p_max 6 bar
Connection: G 1/2, G 1 1/2 male thread

Conductive Switch § 19 WHG

Stainless steel, Hastelloy, Titanium, Coating: Polypropylene, PTFE

Model: NEW



t_max 60°C; p_max atmospheric
Connection: G 1, G 1 1/2 male thread





Level Switches

Conductive Switch PP, PPS

Model: NEK



t_{max} 85 °C; p_{max} 20 bar
Connection:
G 3/4 male thread, 3/4" NPT male
Open-Collector or relay

Conductive Switch Stainless steel, PEEK

Model: LNK



Measuring range: 4 - 1500 mm
 t_{max} 150 °C; p_{max} 10 bar
Connection:
G 1/2, G 1 male thread, hygienic
installation system LZE
Open-Collector

Conductive Switch Compact Probe

Stainless steel, PEEK

Model: LNK-K



Measuring range: 4 - 1500 mm
 t_{max} 150 °C; p_{max} 10 bar
Connection: G 1/2 male thread, hygienic
installation system LZE
Open-Collector

Electrode Relays for Conductive Switches

Model: NE-104, -304



2 limit contacts or
2 Min/Max control switches
Switch capacity: max. 250 V_{AC},
5 A, 600 VA

Electrode Relay § 19 WHG

Model: NE-204



2 limit contacts or
2 Min/Max control switches
Switch capacity: max. 250 V_{AC},
5 A, 600 VA

Head Mounted Transmitter for Conductive Probes

Model: LNR



t_{max} 80 °C
Open-Collector

Microwave Switch

Stainless steel, PEEK

Model: LNM



t_{max} 100 °C (150 °C for CIP); p_{max} 10 bar
Connection: G 1/2, M12 x 1,5 male thread,
hygienic installation system LZE
Open-Collector

Capacitive Switch Liquids

Stainless steel, PEEK

Model: LNZ



t_{max} 100 °C (150 °C for CIP); p_{max} 10 bar
Connection: G 1/2 male thread, hygienic
installation system LZE
Open-Collector

Capacitive Switch Liquids

Stainless steel, PVDF

Model: NCW



t_{max} 90 °C; p_{max} 10 bar
Connection: G 1, G 2 male thread,
Adapter: G 1 1/4, G 1 1/2, round flange,
weld-in sleeve
1 relay, SPDT

Capacitive Switch Liquids - High Temperature

Stainless steel

Model: NCW-H



t_{max} 125 °C; p_{max} 10 bar
Connection: G 1, G 2 male thread,
Adapter: G 1 1/4, G 1 1/2, round flange,
weld-in sleeve
1 relay, SPDT

Ultrasonic Switch Liquids

Stainless steel

Model: NQ-1000



t_{max} 125 °C; p_{max} 20 bar
Connection: R 1 male thread
1 switch output

Optical Switch Liquids

Polypropylene, stainless steel

Model: OPT



t_{max} 80 °C; p_{max} 10 bar
Connection: G 1/2, 1/2" NPT male thread or
M14 with bulkhead nut
Open-Collector

Vibration Switch Liquids

Stainless steel

Model: NWS-***20



t_{max} 130 °C (150 °C for CIP); p_{max} 50 bar
Viscosity: max. 5000 mm²/s
Connection: R-/NPT-thread, DIN-/ANSI-
flange, Tri-Clamp, milk connection DIN
11851, Aseptic DIN 11864, DRD-flange

Vibration Switch Liquids - Plug Connection

Stainless steel

Model: NWS-***2*ES...



t_{max} 90 °C (150 °C for CIP); p_{max} 45 bar
Viscosity: max. 5000 mm²/s
Connection: R-/NPT-thread, DIN-/ANSI-
flange, Tri-Clamp, milk connection DIN
11851, Aseptic DIN 11864, DRD-flange

Vibration Switch Liquids - Cable Connection

Stainless steel

Model: NWS-***2*F...



t_{max} 90 °C (150 °C for CIP); p_{max} 45 bar
Viscosity: max. 5000 mm²/s
Connection:
R-/NPT-thread, DIN-/ANSI-flange,
Tri-Clamp, sanitary connection DIN 11851,
Aseptic DIN 11864, DRD-flange

Vibration Switch - Bulk Materials

Stainless steel

Model: NSV



Switching range: 230 - 3000 mm
Density: 0.06 kg/dm³
 t_{max} 80 °C; p_{max} atmospheric
Connection: G 1 1/2 male
1 relay, SPDT



Level Meter/Transmitters

Vibration Switch - Bulk Materials

Stainless steel

Model: NVI



Switching range: 235 mm
Density: 0.05 kg/dm³
t_max 160 °C; p_max 25 bar
Connection: G 1½, 1½" NPT male
1 relay, SPDT

Diaphragm Switch - Bulk Materials

Neoprene, FPM, steel, st. steel

Model: NMF



t_max 200 °C; p_max 1 bar (over-pressure secure)
Connection: flange

Rotation Vane Switch - Bulk Materials

Stainless steel

Model: NIR-9/NIR-E9



Switching range: 65 - 4000 mm
t_max 200 °C; p_max 0.5 bar
Connection: G 1 male, Adapter: G 1¼, G 1½, round flange, weld-in sleeve
1 relay, SPDT

Capacitive Switch - Bulk Materials

Stainless steel, PTFE

Model: NSC



Switching range: 265 - 3000 mm
t_max 80 °C; p_max 0.5 bar
Connection: G 1 male, Adapter: G 1¼, G 1½, round flange, weld-in sleeve
1 relay, SPDT

Pendulum Level Monitor Bulk Materials

Aluminium, EPDM

Model: PLS



Pendulum length up to 2000 mm
t_max 80 °C; p_max -0.1 ... 0.5 bar
Process connection: aluminium flange
Contact: max. 250 V_AC/3A

Float Transducer - Reed Chain Bulk Materials

Stainless steel, PVC, PP, PTFE, PE

Model: NM



Measuring range: 300 - 6000 mm
Density: 0.6 kg/dm³
t_max 130 °C; p_max 20 bar
Connection: G ¾ ... 2 male thread, flange DN 50 ... 100
Accuracy: ±10 mm

Float Transducer - Reed Chain with Transmitter Bulk Materials

Stainless steel, PVC, PP, PTFE

Model: NM and ADI



Measuring range: 300 - 6000 mm
Density: 0.6 kg/dm³
t_max 130 °C; p_max 20 bar
Connection: G ¾ ... 2 male, flange DN 50 ... 100
Accuracy: ±10 mm

Float Magnetostrictive Bulk Materials

Stainless steel

Model: NMT



Measuring range: 300 - 4000 mm
Density: 0.7 kg/dm³
t_max -20 ... +70 °C; p_max PN 10
Connection: G 2, 2" NPT male
Analogue output
Accuracy: ±1 mm

Capacitive Measurement Bulk Materials

Stainless steel, PVDF

Model: NMC



Measuring range: 265 - 4000 mm
t_max 125 °C; p_max 10 bar PN 10
Connection: G 1, G 2 male thread, Adapter: G 1¼, G 1½, round flange, weld-in sleeve
Analogue output
Measuring error: 1.5% of probe length

Potentiometric Measurement Bulk Materials

Stainless steel

Model: LNP



Measuring range: 200 - 2000 mm
t_max 120 (150) °C; p_max 10 bar
Connection: G 1, 1" NPT male thread, hygienic installation system LZE
Analogue output
Accuracy: ±1 % of probe length

Bypass Glass Gauge Bulk Materials

Stainless steel, PP

Model: SZM



Measuring range: 370 - 3080 mm
t_max 0 ... 100 °C; p_max 10 bar
Connection: flange DN15 ... 32

Mini Bypass with Roller Indicator Bulk Materials

Stainless steel

Model: NBK-M



Measuring range: 200 - 3000 mm
Density: 0.8 kg/dm³
t_max 200 °C; p_max PN 40
Connection: flange DN 10 ... 25, ANSI ½" ... 1"
Accuracy: ±1 mm (transmitter)

Bypass with Roller Indicator Bulk Materials

Stainless steel

Model: NBK-03,-06,-07,-10,-31,-32,-33



Measuring range: 300 - 5500 mm over 5500 mm 2-piece or multipart
Density: min. 0.54 kg/dm³
t_max 400 °C; p_max PN 320
Accuracy: ±1 mm (transmitter)

Bypass with Roller Indicator Bulk Materials

Stainless steel

Model: NBK-ATEX, -GL

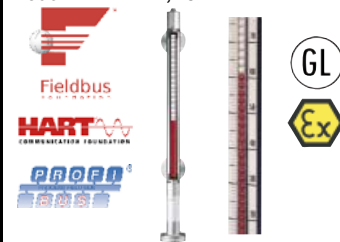

Measuring range: 300 - 5500 mm over 5500 mm 2-piece or multipart
Density: 0.54 kg/dm³
t_max 400 °C; p_max PN 100
Accuracy: ±10 mm (transmitter)

Bypass Over-Top Tank Measurement Bulk Materials

Stainless steel

Model: NBK-04



Measuring range: 300 - 4000 mm
Density: 0.43 kg/dm³
t_max 120 °C; p_max PN 16
Connection: flange DN 50, 65 ANSI 2", 2½"
Accuracy: ±10 mm (transmitter)

Bypass Level Roller Indicator Measurement - Plastic Bulk Materials

PP, PVC, PVDF

Model: NBK-15,-16,-17



Measuring range: 200 - 4000 mm
Density: 0.57 kg/dm³
t_max 80 °C; p_max 4 bar
Connection: flange DN 20 ... 50, ANSI ¾" ... 2"
Accuracy: ±10 mm





Level Switches/Transmitters

Bypass Roller Indicator Low Cost

Stainless steel
Model: NBK-01



Measuring range: 300 - 5500 mm over 5500 mm 2-piece or multipart
Density: 0.54 kg/dm³
t_{max} 400 °C; p_{max} PN 100
Accuracy: ±1 mm (transmitter)

Bypass Roll Measuring Rope PVC

Model: NBK-19



Measuring range: 0.2 - 4,8 m
Density: 1 kg/dm³
t_{max} 60 °C; p_{max} atmospheric
Accuracy: ± 1 mm (transmitter)

Limit Contact for Bypass Measurement

Aluminium, Polycarbonate
Model: NBK-R, RT



t_{max} 400 °C
Switch capacity: 80 VA, 250 V_{AC/DC}, 1 A

Limit Contact for Bypass Measurement

Model: NBK-RA



t_{max} 85 °C
Switch capacity: 45 VA, 230 V_{AC/DC}, 0,6 A

Limit Contact for Bypass Measurement

Model: NBK-RV, -RN



t_{max} 200 °C
Switch capacity:
5 W, 400 V_{DC}/ 230 V_{AC}, 0,5 A

Displacement Level Meter

Stainless steel
Model: BA



Measuring range: 300 - 6 000 mm
Density range: 400 - 2000 g/l
t_{max} 250 °C; p_{max} PN 400
Connection: flange DN 50, ANSI 2"
Analogue output, 2 limit contacts
Accuracy: ± 5 mm

Guided Wave Radar (TDR) for process industry - rod probe

Stainless steel, PTFE
Model: NGM



Measuring range: 100 - 3000 mm (liquids)
t_{max} 250 °C; p_{max} 40 bar
Connection: thread, flange
Analogue output, switching output
Accuracy:
±3 mm or 0,03 % of measured value

Guided Wave Radar (TDR) for process industry - coax probe

Stainless steel
Model: NGM



Measuring range: 100 - 6000 mm (liquids)
t_{max} 250 °C; p_{max} 40 bar
Connection: thread, flange
Analogue output, switching output
Accuracy:
±3 mm or 0,03 % of measured value

Guided Wave Radar (TDR) for process industry - rope sensor

Stainless steel
Model: NGM



Measuring range:
1000 - 20000 mm (solids)
t_{max} 150 °C; p_{max} 40 bar
Connection: thread, flange
Analogue output, switching output
Accuracy:
±3 mm or 0,03 % of measured value

Guided Wave Radar (TDR) for process industry - with Bypass

Stainless steel
Model: NGM



Measuring range: 100 - 3000 mm (liquids)
t_{max} 250 °C; p_{max} 40 bar
Connection: thread, flange
Accuracy:
±3 mm or 0,03 % of measured value

Guided Wave Radar (TDR) for engineering/factory automation

Stainless steel, PTFE
Model: NGF



Measuring range: 200 - 2000 mm (liquids)
t_{max} 100 °C; p_{max} 10 bar
Connection: G ¾, ¾" NPT male
Analogue output, switching output
Accuracy: ±5 mm

Ultrasonic Measurement

PP

Model: NUS-4



Measuring range: 0.2 - 25 m (liquids)
t_{max} 90 °C; p_{max} 3 bar abs
Connection:
G 1½, G 2, 1½" NPT, 2" NPT male, DN 80, DN 125, DN 150, ANSI 3", 5", 6"
Analogue output
Accuracy: ±0.2 % of reading ±0.05 % of f. s.

Pressure Transmitter with Diaphragm Seal

St. steel, Monel, Tantalum, Hastelloy, PTFE
Model: PAD-...N

High Quality - Low Cost



Level:
0 ... +2500 mmWC ... 0 ... +150 mWC
t_{max} 200 °C
Connection: flange via neck tube DN 50 or bigger
Accuracy: ±0.075% of calibrated span + influence of diaphragm seal

Pressure Transmitter with Diaphragm Seal

St. steel, Monel, Tantalum, Hastelloy, PTFE
Model: PAS-...N

High Quality - Low Cost



Level:
0 ... +2500 mmWC ... 0 ... +150 mWC
t_{max} 350 °C
Connection: Thread or flange DN 50 or bigger
Accuracy: ±0.075% of calibrated span + influence of diaphragm seal

Deep-Well Probe

Stainless steel, cable polyurethane
Model: NTB



Measuring range: 0 - 1 ... 0 - 200 mWS
Cable length 200 m
Accuracy: ± 0.5 % of full scale

Hydrostatic Diaphragm Measurement

Stainless steel
Model: NPF



Measuring range:
0 - 600 ... 0 - 10000 mmWS
t_{max} 80 °C
Connection: G ½ male, ½" NPT, DN 50 ... DN 100, ANSI 2" ... 4"
Accuracy: ± 1.6 % of full scale



Temperature Switches/indicators

Bi-metal Switch
Brass, stainless steel
Model: TWR



Switching range: +30 ... +120°C
t_{max} 150°C; p_{max} 64 bar
Connection: G 3/4 male thread

Thermal Reed Switch
Brass, stainless steel
Model: TRS



Switching range: +10 ... +120°C
t_{max} 120°C; p_{max} 25 bar
Connection: G 1/4...1, 1/2...1 NPT

Temperature Switch Digital
Stainless steel
Model: TDD-1, -3, -5, -7



Measuring range: -20 ... +120°C
t_{max} 125°C; p_{max} 80 bar
Connection: G 1/2, G 3/4, 1/2 NPT, 3/4 NPT male thread
2 limit contacts
Accuracy: ±0.5°C

Temperature Switch Digital
Stainless steel
Model: TDD-...D6



Measuring range: -50 ... +125°C
t_{max} 125°C; p_{max} 80 bar
Connection: smooth probe Ø 6 mm
2 limit contacts
Accuracy: ±0.5°C

V-Form - Machinery Glass Thermometer
Aluminium casing, brass
Model: TGL



Measuring range:
-60 ... +40°C ... 0 ... +200°C
Connection: G 1/2, 1/2 NPT male thread
Accuracy: ± 1 % of full scale

V-Form - Machinery Glass Thermometer
Plastic casing, brass
Model: TGK



Measuring range:
-60 ... +40°C ... 0 ... +200°C
Connection: G 1/2, 1/2 NPT male thread
Accuracy: ± 1 % of full scale

Bi-metal Thermometer
Copper alloy, steel, stainless steel
Model: TBI-I/ TBI-S



Measuring range: -30 ... +500°C
p_{max} 25 bar
Connection:
G 1/2 male thread, welding sleeve
Accuracy: Cl. 1.0 according to VDI

Bi-metal Thermometer
Stainless steel
Model: TBE



Measuring range:
-50 ... +50°C...0...+600°C
p_{max} 15 bar
Connection: G 1/2...3/4, 1/2" ... 3/4" NPT, fixed, rotatable, slidable
Accuracy: Cl. 1,0

Shaft Thermometers according to DIN 16205
Stainless steel
Model: TNS



Measuring range:
-40...+40°C ... 0 ... +600°C
p_{max} 25 bar
Connection: G 1/2...1, 1/2...1 NPT, DIN 11851, Tri-Clamp, helix probe
Accuracy: Cl. 1.0 ; 1.6

Capillary Thermometer according to DIN 16206
Stainless steel
Model: TNF



Measuring range:
-40...+40°C ... 0 ... +600°C
p_{max} 25 bar
Connection: G 1/2...1, 1/2...1 NPT, DIN 11851, Tri-Clamp, helix probe
Accuracy: Cl. 1.0 ; 1.6

Safety Thermometer with Contacts
Stainless steel
Model: TNS,TNF



Measuring range:
-40...+40°C ... 0 ... +600°C
p_{max} 25 bar
Connection: G 1/2...1, 1/2...1 NPT, DIN 11851, Tri-Clamp, helix probe
Accuracy: Cl. 1.0 ; 1.6

Shaft Thermometer for Diesel Engines
Steel, stainless steel
Model: TND



Measuring range:
0 ... +600°C ... 0 ... +800°C
p_{max} 25 bar
Connection: G 1/2, G 3/4 male thread
Accuracy: Cl. 1.0 ; 1.6

Thermowells for Shaft and Capillary Thermometer
Stainless steel
Model: TSH



p_{max} 25 bar
Connection:
G 1/2 male thread, welding sleeve

Electronic Temperature Sensor
Stainless steel
Model: TDA



Measuring range: -20 ... +120°C
p_{max} 80 bar
Connection:
G 1/2, G 3/4, 1/2 NPT, 3/4 NPT male
Analogue output, limit contact
Accuracy: ± 0.5°C

Electronic Temperature Sensor
Stainless steel
Model: TDA-...D6



Measuring range: -50 ... +125°C
p_{max} 80 bar
Connection: smooth probe Ø 6 mm
Analogue output, limit contact
Accuracy: ±0.5°C

Infrared Fixed Thermometer
Stainless steel
Model: TIR-SA



Measuring range:
0 ... +120°C ... 100 ... +500°C
4...20 mA, 10 mV/K or voltage model J, K
Accuracy: ± 1.5 % of full scale





Temperature Switches/indicators

Infrared Fixed Thermometer

Stainless steel

Model: TIR-S



Measuring range:
-20...+300 °C ... +1100 ... +2500 °C
Analogue output
Accuracy: ±1.5 % of full scale

Precision Hand-Held Thermometer

Model: HND-T120



Measuring range: -50... +1150 °C
Sensor: Type K (NiCr-Ni)
Accuracy: 0.1 – 1.5 % of reading

Precision Hand-Held Thermometer

Model: HND-T125



Measuring range: -50... +1150 °C
Sensor: Type K (NiCr-Ni)
Accuracy: ±0.1 – 1.5 % of reading

Precision Hand-Held Thermometer

Model: HND-T105, -T205, -T110



Measuring range: -65... +1768 °C)
Sensor:
Pt 100 or thermocouple types K, N, S
Option: Logger, alarm, control function
Accuracy: ±0.03 % of full scale

Double/Differential Hand-Held Thermometer

Model: HND-T115, -T215



Measuring range: -220 ... +1750 °C
Sensor: thermocouple types K, N, S, J, T
Accuracy: ±0.03 % of full scale

Digital Thermometer

Stainless steel

Model: DTM



Measuring range:
-30 ... +40 °C ... 0 ... +400 °C
p_{max} 25 bar
G ½...1, ½...1 NPT
Analogue output, limit switches
Accuracy: Cl. 0,5

Temperature Sensor

Brass, stainless steel

Model: TSA



Measuring range: -40 ... +150 °C
t_{max} 150 °C; p_{max} 25 bar
G ¼...1, ¼...1 NPT
Accuracy: from 0.7 °C

Resistance Thermometer

Brass, bronze, stainless steel

Model: TNK



Measuring range: -80 ... +150 °C
t_{max} 150 °C; p_{max} 50 bar
M18x1,5; G ½; ½ NPT
Accuracy: Cl. A or B

Screw-In Resistance Thermometer

Brass, stainless steel

Model: TMA with AUF and KUG-S



Measuring range:
0 ... +50 °C ... -200 ... +600 °C
p_{max} 36 bar
Accuracy: Cl. B

Resistance Temperature Probe with Connection Box

Model: LTS-A



Measuring range: -50 ... +250 °C
p_{max} 10 bar
Connection: G ½, M12x1,5 male thread,
hygienic installation system LZE
Accuracy: Cl. A

Resistance Temperature Probe- Compact Version

Stainless steel

Model: LTS-K



Measuring range: -50 ... +250 °C
p_{max} 10 bar
Connection: G ½, M12x1,5 male thread,
hygienic installation system LZE
Pt 100, 4...20 mA
Accuracy: Cl. A

Temperature Transducer- Head Mounting

Model: KM-1/-3



Measuring range:
-200 ... +250 °C ... -50 ... +1768 °C
Input: RTD, TC, Ω, mV
Analogue output

Temperature Transducer Rail or Wall Mounting

Model: KM-6



Measuring range:
-200 ... +250 °C ... -50 ... +1768 °C
Input: RTD, TC, Ω, mV
Analogue output

Screw-In Resistance Thermometer according to DIN

Stainless steel

Model: TWD-B



Measuring range: -80 ... +600 °C
p_{max} 25 bar (40 bar)
Connection: G ½...1, ½...1 NPT
Analogue output
Accuracy: Cl. A or B

Weld-In and Insertion Resistance Thermometer according to DIN

Stainless steel

Model: TWD-D, -F



Measuring range: -80 ... +600 °C
p_{max} 25 bar (40 bar)
Analogue output
Accuracy: Cl. A or B

Pipe Resistance Thermometer

Stainless steel

Model: TWP



Measuring range: -20 ... +200 °C
Union nut DIN 11851 DN 25...100
Accuracy: Cl. A or B



Temperature Indicators

Screw-In Resistance Thermometer

Stainless steel

Model: TWE-1



Measuring range: -20 ... +600°C
Connection: G 1/4, G 1/2, M 10
Accuracy: Cl. A or B

Screw-In Resistance Thermometer

Stainless steel

Model: TWE-2



Measuring range: -20 ... +400°C
Connection: M 10
Accuracy: Cl. A or B

Screw-In Resistance Thermometer

Stainless steel

Model: TWE-3



Measuring range: -20 ... +300°C
Connection: M 8
Accuracy: Cl. A or B

Insertion Resistance Thermometer

Stainless steel

Model: TWE-5



Measuring range: -20 ... +350°C
Accuracy: Cl. A or B

Immersion-/Insertion Resistance Thermometer

Stainless steel

Model: TWE-5



Measuring range: -20 ... +350°C
Accuracy: Cl. A or B

Screw-In Resistance Thermometer

Stainless steel

Model: TWE-5



Measuring range: -20 ... +150°C
Connection: G 1/4, G 1/2, G 3/4, M 12
Accuracy: Cl. A or B

Sheath Resistance Thermometer

Stainless steel

Model: TWM



Measuring range: -20 ... +600 °C
Accuracy: Cl. A or B

Resistance Temperature Measuring Unit

Stainless steel

Model: TWL

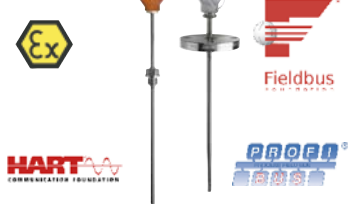

Measuring range: -200 ... +750°C
p_{max} 250 bar
Connection: Thread, flange, weld-in sleeve
Pt 100, 4...20 mA
Accuracy: Cl. A or B

Room Thermometer

Aluminium

Model: TWL-ST

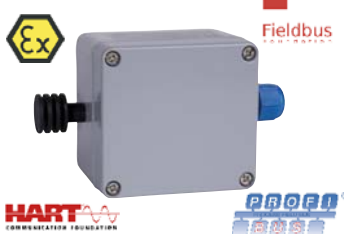

Measuring range: -20 ... +60°C
p_{max} atmospheric
Wall socket
Pt 100, 4...20 mA
Accuracy: Cl. A or B

Contact Resistance Thermometer

Aluminium, stainless steel

Model: TWA



Measuring range: -20 ... +260°C
Accuracy: Cl. A or B

Weld-In and Insertion Thermocouples according to DIN

Steel, stainless steel, ceramic

Model: TTD



Measuring range: -200 ... +1 150 °C
p_{max} 25 bar (40 bar)
Connection: G 1/2 male thread
Accuracy: Cl. 1.0

Screw-In Thermocouples with Compensating Lead

Stainless steel

Model: TTE-1



Measuring range: -200 ... +600°C
Connection: G 1/2, M10x1
Accuracy: Cl. 1.0

Insertion Thermocouples with Bayonet Lock

Stainless steel

Model: TTE-1



Measuring range: 0 ... +400°C
Accuracy: Cl. 1.0

Immersion-/Insertion Thermocouples with Compensating Lead

Stainless steel

Model: TTE-1



Measuring range: 0 ... +600 °C
Accuracy: Cl. 1.0

Immersion and Insertion Thermocouples

Stainless steel

Model: TTL



Measuring range: -200 ... +1 600 °C
p_{max} 250 bar
Connection: thread, flange, weld-in sleeve
4 ... 20 mA
Accuracy: Cl. 1.0 or 2.0

Sheath - Thermocouples

Brass, stainless steel

Model: TTM

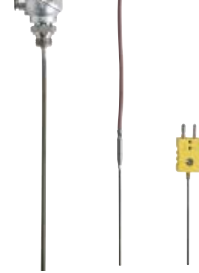

Measuring range: -50 ... +1 100 °C
Accuracy: Cl. 1.0





Analysis

Transmitter for pH-Value and ORP

Model: APM-1



Outputs: 1 binary output,
2 analogue outputs
Switch output:
2 relays with adjustable setpoints

pH-Combined Electrodes

Glass, plastic

Model: APS



Measuring range: pH 1...12
 t_{max} 80 °C; p_{max} 10 bar
Diaphragm: PTFE-ring or ceramic

pH-, Redox- and Temperature Hand-Held Measurement

Model: HND-R



Measuring range: pH: 0...14;
Redox: -1999...+2000 mV
Temperature: -100...+250 °C
Accuracy: ± 0.01 pH; ± 0.1 % of reading

Transmitter for Specific Conductivity

Model: ACM-1



Measuring range: 0...200 mS/cm
Outputs: 1 binary output,
2 analogue outputs,
Switch output:
2 relays with adjustable setpoints

Conductive/Inductive Conductivity Measuring Cells

Stainless steel, graphite

Model: ACS



Measuring range:
0.05 μ S/cm... 15 mS/cm
 t_{max} 150 °C; p_{max} 16 bar
Process connection G $\frac{3}{4}$ male

Inductive Conductivity Measuring System

PEEK, PVDF, stainless steel

Model: LCI



Measuring range: 0...2000 mS/cm
 t_{max} 150 °C; p_{max} 10 bar
integrated Pt 100
Accuracy: $\pm 0.5 - 1$ % of full scale

Hand-Held Conductivity Measuring Unit

Model: HND-C



Measuring range:
0...200 μ S/cm -0... 200 mS/cm
Options: Resistance, salinity, TDS
Accuracy: from $\pm 0,1\%$

Humidity/Temperature Transmitter

Model: AFK-G2



Measuring range:
0...100 % rH; -60...200 °C
 t_{max} 200 °C; p_{max} 25 bar
Outputs: 2 x 4...20 mA
Accuracy: ± 2 % rH

Humidity Transmitter with Display

Model: AFA-G



Measuring range: 5...95 % rH; 0...60 °C
 t_{max} 80 °C
Outputs: 4...20 mA
Accuracy: ± 2 % rH

Humidity/Temperature Transmitter

Model: AFK-E



Measuring range: 0...100 % rH;
-40...+180 °C
 t_{max} 180 °C; p_{max} 15 bar
Outputs: analogue outputs and switches
Accuracy: ± 1.6 % of reading % rH

Hygostat, Humidity Annex Switch

Model: AFS-G1, AFS-G2, AFS-G3



Measuring range: 30...100 % rH
 t_{max} 60 °C
Switch output: 1 SPDT
Accuracy: 3 % rH

Hand-Held Humidity Precision Measuring Unit

Model: HND-F



Measuring range: 0... 100% rH
Integrated Pt 1000
Accuracy: $\pm 0.1 - 0.2$ %

Turbidity Measuring System

Stainless steel

Model: ATA-K, ATS-K



Measuring range: 0... 500 ppm;
0... 4 CU, 0... 10 - 200 FTU
 t_{max} 150 °C; p_{max} 16 bar
Output: 4...20 mA
Accuracy: ± 2 % of full scale

Transmitter for Turbidity Measuring System

Model: ATT-K



Output: 4...20 mA
Switching Output:
2 Alarm contacts (potential-free SPDT),
1 Alarm (lamp and function control)

Turbidity Probe

Stainless steel

Model: ATL



Measuring range:
0... 500 ppm; 0... 4 CU
 t_{max} 90 °C; p_{max} 10 bar
Outputs: 4...20 mA
Accuracy: ± 2 % of full scale

Density Meter

Stainless steel

Model: DWF



Measuring range: 700... 1900 g/L
 t_{max} 150 °C
Process connection
flange DN 25...50, ANSI 1"...2"
Accuracy: ± 1.25 ...6 g/L



Food and Pharmaceutical

Calimetric Meter/Switch
Stainless steel

Model: KAL-K4440



Water: 0.04 – 2 m/s
 t_{max} 120 °C; p_{max} 100 bar
 Connection:
 G 1/4 ... 1 1/2, 1/4 ... 3/4 NPT, M12, Tri-Clamp

Variable Area - All Metal

Stainless steel, special material

Model: BGN-...E

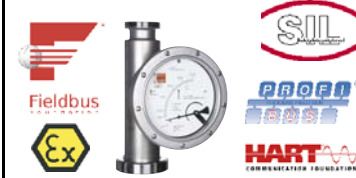

Water: 0.5 – 5 L/h ... 13000 – 130000 L/h
 Air:
 0.015 – 0.15 Nm³/h ... 240 – 2400 Nm³/h
 t_{max} 350 °C; p_{max} PN 40
 Connection:
 Union nut DIN 11851 DN 20...100
 Accuracy: ± 1.6 – 2.2 % of full scale

Electromagnetic Measurement

Stainless steel, PTFE, PVDF

Model: DMH



Water: 0 – 1 m³/h ... 0 – 280 m³/h
 t_{max} 150 °C; p_{max} PN 40
 Connection: 1/2" ... 4" Tri-Clover,
 DN 15 ... DN 100 sanitary acc. to DIN 11851
 Accuracy: ± 0,3 % of reading
 ± 0.01 % of full scale

Contact Pressure Gauge with Diaphragm Seal, DIN 11851

Stainless steel

Model: MAN-RF...M21...DRM-602



Measuring range: 0 ... +1 bar ... 0 ... +40 bar
 Housing: Ø 100, 160 mm
 Connection:
 Union nut DIN 11851 DN 20...100
 Accuracy: Cl. 1.6

Digital Pressure Gauges with Diaphragm Seals for Homogenizing Machines

Stainless steel

Model: SEN...DRM-189...AUF



Measuring range:
 0 ... +100 bar ... 0 ... +600 bar
 Membrane: flush mounted
 t_{max} 100 °C
 Connection: for block flange
 Accuracy: Cl. 1.0

Conductive Switch / Compact Probe

Stainless steel, PEEK

Model: LNK-K



Measuring range: 4 – 1 500 mm
 t_{max} 150 °C; p_{max} 10 bar
 Connection: G 1/2 male G 1 male, hygienic
 installation system LZE
 Open-Collector

Microwave Switch

Stainless steel, PEEK

Model: LNM



t_{max} 100 °C (150 °C for CIP); p_{max} 10 bar
 Connection:
 G 1/2, M12 x 1,5 male thread, hygienic
 installation system LZE
 Open-Collector

Capacitive Switch Liquids

Stainless steel, PEEK

Model: LNZ



t_{max} 100 °C (150 °C for CIP); p_{max} 10 bar
 Connection: G 1/2 male thread, hygienic
 installation system LZE
 Open-Collector

Capacitive Switch Bulk Materials

Stainless steel, PTFE

Model: NSC



Switching range: 265 – 3000 mm
 t_{max} 80 °C; p_{max} 0.5 bar
 Connection: G 1 male thread, Adapter:
 G 1 1/4, G 1 1/2, round flange, weld-in sleeve
 1 relay, SPDT

Potentiometric Measurement

Stainless steel, PEEK

Model: LNP



Measuring range: 200 – 2000 mm
 t_{max} 120 °C; p_{max} 10 bar
 Connection: G 1, 1 NPT male thread
 Accuracy: ± 1 % of probe length

Vibration Switch Bulk Materials

Stainless steel

Model: NSV



Switching range: 230 – 3000 mm
 Density: 0.06 kg/dm³
 t_{max} 80 °C; p_{max} atmospheric
 Connection: G 1 1/2 male
 1 relay, SPDT

Vibration Switch Liquids

Stainless steel

Model: NWS-...2ES



t_{max} 130 °C (150 °C for CIP); p_{max} 50 bar
 Connection: R-/NPT-thread, DIN-/ANSI-
 flange, Tri-Clamp, milk connection DIN
 11851, Aseptic DIN 11864, DRD-flange

Rotation Vane Switch - Bulk Materials

Stainless steel

Model: NIR-9/E9



Switching range: 65 – 4000 mm
 t_{max} 200 °C; p_{max} 0.5 bar
 Connection: G 1 male, Adapter: G 1 1/4,
 G 1 1/2, round flange, weld-in sleeve
 1 relay, SPDT

Resistance Temperature Probe with Connection Box / Compact Version

Stainless steel

Model: LTS-A/-K



Measuring range: -50 ... +250 °C
 p_{max} 10 bar
 Connection: G 1/2, M12 x 1,5 male thread,
 hygienic installation system LZE
 Pt 100, 4 ... 20 mA
 Accuracy: Cl. A

Capillary Thermometer according to DIN 16206

Steel, aluminium, stainless steel

Model: TNF



Measuring range:
 -40 ... +40 °C ... 0 ... +600 °C
 p_{max} 25 bar
 Connection: G 1/2 ... 1, 1/2 ... 1 NPT,
 DIN 11851, Tri-Clamp, helix probe
 Accuracy: Cl. 1.0 ; 1.6

Hygienic Mounting Systems

Stainless steel

Model: LZE



t_{max} 250 °C; p_{max} 10 bar
 M12 x 1,5; G 1/2; G 1
 Seals: metallic, PEEK-ring





Assemblies

Flow Regulators

Brass, stainless steel

Model: REG

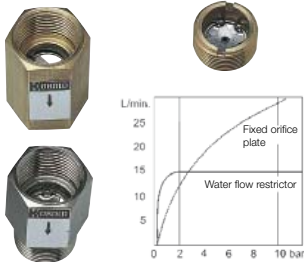

Viscosity range: 1 – 30 mm²/s
Flow rates: 0.5 – 40 L/min
t_{max} 300 °C; p_{max} 200 bar
G ½, G ¾, ¼ NPT

Flow Regulators - Multiple Element

Brass, stainless steel

Model: REG-8



Viscosity range: 1 – 30 mm²/s
Flow rates: 1 – 280 L/min
t_{max} 300 °C; p_{max} 200 bar
Flange DN 20...50

Flow Regulators - Multiple Element

Brass, stainless steel

Model: REG-9



Viscosity range: 1 – 30 mm²/s
Flow rates: 1 – 280 L/min
t_{max} 300 °C; p_{max} 200 bar
G 1½...G 2½

Brass/Stainless Steel Ball Valves

Model: KUG-TB,-VN,-VC/KUG-ZE,-KD



t_{max} 180 °C; p_{max} PN 64
G ¼ ... 4 female thread
hand lever, 1-, 2- and 3-piece versions

Grey Cast Iron/Stainless steel- Flange-Ball Valves

Model: KUG-VO, -VK



t_{max} 180 °C; p_{max} PN 40
Flange DN 15...200
according to DIN 3202 F4/5

Ball Valves Shut-off for Measuring Device

Brass, stainless steel

Model: KUG-S



t_{max} 120 °C; p_{max} PN 25
G ½ ... 2 female thread
Sensor support: G ¼, G ½

Brass/Stainless steel Ball Valves with Pneumatic Actuator

Model: KUP-KA, -VN, -ZA, -VH, -PD



t_{max} 120 °C; p_{max} PN 16
G ½...4 female thread
Control pressure: 6 – 8 bar
Single or Double acting
T- and L-bore

Grey Cast Iron/ Stainless steel- Flange Ball Valves with Pneumatic Actuator

Model: KUP-VO, -VK



t_{max} 160 °C; p_{max} PN 16
Flange DN 15...200
Control pressure: 6 – 8 bar
Single or double acting

Accessories for Pneumatic Actuator

Model: KUP-RE

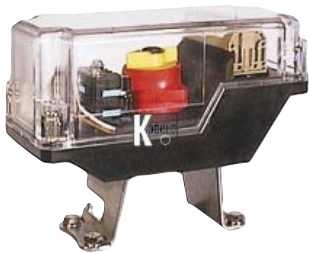

3/2- and 5/2-way solenoid valve several voltages, mechanical limit switch and proximity switch

Butterfly Valves

Aluminium, GGG-40

Model: KLA



t_{max} 200 °C; p_{max} PN 16
Flange DN 40...300
Seals: NBR, FKM, PTFE

Butterfly Valves with Pneumatic Actuator

Aluminium, GGG-40

Model: KLP



t_{max} 200 °C; p_{max} PN 16
Flange DN 40...300
Seals: EPDM, FKM
Control pressure: 6 – 8 bar
Double acting or spring resetting

Needle Valve

Brass

Model: NAD-AC



t_{max} 100 °C; p_{max} PN 100
G ½ ... 2 female thread

Needle Valve - Stainless Steel

Model: NAD-M, -Z



t_{max} 120 °C; p_{max} PN 250
G ½...1¼, ½...1 NPT

Angle Seat Valves

Brass, stainless steel

Model: NAD-AD, -BE



t_{max} 180 °C; p_{max} PN 16
G ¾ ... 3 female thread

Outlet Globe Valves

Brass, stainless steel

Model: NAD-AB, -BF



t_{max} 130 °C; p_{max} PN 16
G ¼ ... 3

Check Valves

Red cast iron, brass, stainless steel

Model: KUR-TD, KUR-MR



t_{max} 110 °C; p_{max} PN 25
G ¼ ... 4 female thread



Assemblies, Control Devices and Relays

Threaded Magnetic Filter
Bronze, brass
Model: MFR



t_{max} 200°C; p_{max} PN 16
Rp ½...3 female thread
Filter grade: 280 µm

Magnetic Filter Dirt Trap
Brass, stainless steel
Model: MFR-IG, MFR-EA



t_{max} 180°C; p_{max} PN 40
G ¾...2 female thread
Filter grade: 250 µm

Flange Magnetic Filter
Grey cast iron
Model: MFF



t_{max} 200°C; p_{max} PN 16
R ½...3, soldering connection
22...35 mm, flange DN 50...200
Filter grade: 750 µm

Air Eliminator
Aluminium
Model: ZAL



t_{max} 70°C; p_{max} 10 bar
Flange ANSI 1" ... 4"
Filter grade: 40 ... 200 µm

Contact Protection Relay
Model: MSR

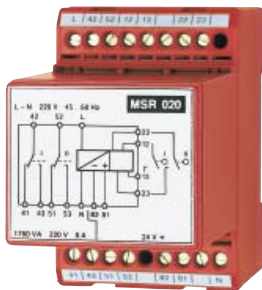

Input: potential-free contacts
1 or 2 relay outputs, SPDT

Isolation Switching Amplifier for Initiators
Model: KFD-2, KFA-6



Input:
Initiators (Namur), potential-free contacts
1 relay, SPDT

Sandwich Plug-On Display
Model: AUF



Input: 4-20 mA loop powered
Option: Open-Collector

KOBUS KOBOLD-BUS-System
Model: BUS



2-wire, Min/Max-values available
configuration with RS232
Plug- & Play-Software

Digital - Panel Mount - Indicators
Model: DAG-A/S/M



Input: current, voltage,
Temperatur, frequency, resistance
Analogue output, limit contacts,
Min/Max-memory

Universal Indicator
Model: ADI-B...X



Input: current, voltage, frequency
Analogue output, 2 limit contacts, sensor
supply

Universal Indicator
Model: ADI-B...F



Input: current, voltage, frequency
Analogue output, 2 limit contacts, sensor
supply

Industrial Dosing, Counter and Flow Indicator
Model: ZOD



Input: frequency
Analogue output, limit contacts, sensor
supply, battery powered

Electronic for Measuring and Monitoring
Model: ZED-K



Input: frequency
Analogue output, 2 limit contacts, sensor
supply

Counter Electronics/ Batch Controller
Model: ZED-Z/-D



Input: frequency
Analogue output, 2 limit contacts,
sensor supply

Industrial Dosing, Counter- and Flow Indicator
Model: DAG-AXI



Input: frequency
4 limit contacts

Electronic Multi-Channel Data Logger
Model: ZLS



Input: 4-20 mA, Pt 100, Pt 500, Pt 1000
interface, sensor supply



Steam Flow Measurement

-Complete solutions from one source-

Example based on a differential pressure transmitter

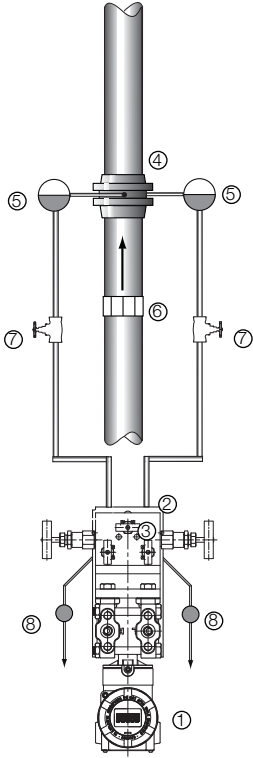

A complete measuring system comprises of:

- ① Differential pressure transmitter PAD
- ② Flat bracket for pipe mounting ZUB-PAD/PAS-L
- ③ 5-way Block valve as accessory PAD
- ④ Orifice flange including orifice plate KPL
- ⑤ Steam condensate chambers as accessory KPL
- ⑥ Flow conditioner as accessory KPL
- ⑦ Shut-off valve as accessory KPL
- ⑧ Separator as accessory KPL

We will gladly prepare a customised offer for you.

Highly accurate steam flow measurement with Vortex flowmeter DVH/DVE from Heinrichs Messtechnik

Steam is one of the most commonly used media in the process industry. It is used for example to heat tanks, pipes or produced for cleaning and sterilizing purposes in various industries.

In all cases, first of all, steam must be generated.

The generation of steam is extremely energy-intensive and for this reason expensive. Therefore it is logical not only to measure the generated steam but also the amount of steam required by the consumer. The more accurately it is done, the more energy-efficient and therefore the more economically the steam can be generated. In times of high energy costs and dwindling resources, precision is required in handling these precious commodities.

The vortex flowmeters from Heinrichs are highly accurate and always offer a functionality tailored specifically for each steam application.

All devices can be equipped optionally with an integrated pressure and temperature measurement, which allows the state of the steam to be determined precisely. The "Energy Monitoring" option which incorporates an additional external temperature sensor, makes energy consumption measurement possible. With up to 3 analogue outputs and 3 alarm outputs, pulse output, and MODBUS interface. The devices offer a vast communication spectrum for the users. A fully welded sensor design without seals also ensures stability and long-life cycle. In-line devices cover pipes up to DN 200 (8"). For bigger sizes an insertion type variant, for up to DN 600 (24") is available.

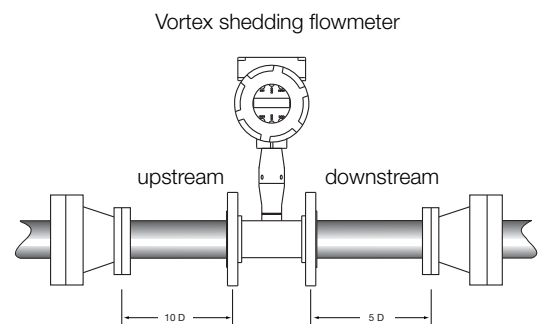

Biogas flow measurement



Task:

Biogas usually refers to gas generated from organic substance in the absence of oxygen. The source of this kind of bio-fuel is organic waste which can be found in many forms including animal waste, human waste, dead plant and other decaying organic matter. As with any other fuel gas, biogas mainly contains Methane (CH₄) and Carbon Dioxide (CO₂).

It is not that hard to understand that harvesting biogas from waste has two advantages, the first one of course you get 'free' energy while at the same time you play your part in keeping the earth greener by reducing the amount of greenhouse gases released to the atmosphere.

Looking at the economical potentiality, companies who own palm plantations are nowadays starting to build and operate their own biogas plants, utilizing vast amount of organic waste from the plantation they run.

One thing you always need to do when running a plant is to make sure that your plant is running efficiently. The simplest or most straight

forward way to achieve this objective is to measure the output of your plant, in this case, the volume of biogas generated.

Measuring the total amount of biogas generated in a biogas plant can be tricky, because you have to deal with a low operating pressure which can be as low as 100 mBar (even at a point downstream of a blower) while on the other hand you have to also consider that biogas is a dirty, humid gas and has the potential to corrode the metal part of the flow meter. And to make it more interesting, biogas is flammable, of course. So, hazardous area certification is a must.

As with any other gas, biogas is compressible, which means that its density varies greatly when there is a change in operational pressure and/or operational temperature. Therefore the operational pressure and temperature must be evaluated to ensure an accurate flow measurement.

Solution:

KOBOLD DOG Oscillation Type - Gas Flow Meter. Thanks to the 'oscillation' working principle and generously dimensioned flow measuring channels, this unit is extremely dirt resistance and has a self cleaning effect, which is crucial for a dirty fluid like biogas. Also as this flow meter has no rotating parts, the pressure drop can be kept to a minimum. One can expect a maximum 50 mbar pressure drop at Q_{max} when the DOG measures gas with the same density as air. And it comes with ATEX II 1G EEx ia IIC T4 approval for hazardous area application.

Other features included in the installed DOG flow meter are anti-corrosion paint and a suitable stainless steel meter run, in order for you to get a good measurement result.

Plus, to include process pressure and temperature variables into the calculation, we installed a PAS Pressure Transmitter and a TWL Temperature Transmitter whose outputs were connected to an external Flow Computer, along with the value received from the flowmeter.

The output we got derive from the above installation package is the corrected value of biogas volumetric flow both in flow rate value (Nm³/h) and total flow value (Nm³).



Applications

Cooling monitoring for Casting Machines

Task: Provide a proportional electrical output with visual indication of flow

The application is cooling water on casting machines with 96 channels. The casting machines are used to produce engine and steering parts, and are installed all over the world; Turkey, Germany, China, USA, Outer Mongolia, and Korea.

The original machines used a turbine flow sensor and separate flow indicator. The customer requested a change due to dirty water clogging the orifice of the turbine sensors.

Solution:

KOBOLD model DF series with an analogue output and clear paddlewheel cover. The reason for the DF is the ability to easily pass suspended solids and not clog and to function as a sight gauge. The DF passed with flying colours. The DF sensor casting manufacturer was able to eliminate both the turbine sensor and flow indicator with one sensor. The DF works well and has become the standard for the customer. The casting method used in this process is considered the best and most productive casting system available.



The DF paddle wheel flow sensor is a reliable and economical solution for monitoring flow of water like media where an output and visual indication is needed!

Heavy duty equipment needs protection you can count on

Task: Cone crusher lubrication monitoring



Mobile cone crushers are used to turn raw materials such as rocks, minerals, ores, reclaimed glass and ceramic into graded usable product. They are versatile and convenient, producing the materials needed for construction at the place where they are needed, saving time and cutting down on transport costs on large civil, mining and recycling projects.

The rocks are fed into a fixed cone which has a rotating eccentric cone inside it. By varying the gap between the cones, the size of product produced can be controlled. At the heart of a mobile cone crusher is the bearing assembly. This is subject to massive pressures, and vibrations, and the machines are used in harsh climatic conditions throughout the world, day in day out.

The bearing assembly is very expensive, is often time consuming to replace and subject to a long delivery time. Correct lubrication of the bearing assembly is therefore paramount to avoid costly downtime. Therefore a dependable means of monitoring the oil supply is required, that will work in extremes of temperature, and be as rugged and as reliable as the rest of the machine.

Solution:

The OVZ flow monitor from Kobold ticks all the boxes. It has a robust durable aluminium body and PMMA cover, which acts as a sight glass, allowing engineers to see at a glance that all is well with the precious oil flow. Its positive displacement technology means that it is viscosity compensated when subjected to temperature extremes. The electronics have been epoxy encapsulated for full protection from ingress or vibration. They combine a wide voltage supply range, DC-DC convertor with interference filter, for a faithful output signal allowing optimal lubrication control.

The OVZ offers great value insurance and accurate, reliable performance; whether used in Australia or Alaska!



Phosphate Precipitation in Waste Water Treatment Plants

Task:

By addition of Iron (III) Chloride ($FeCl_3$) in the aeration basin, the phosphates dissolved in excess waste water are chemically mixed with sludge flocculants and transferred with sludge to the sludge treatment stage.

This process reduces phosphate concentration in our waterways and therefore minimises the potential for abnormal algae growth, and the detrimental effect for the aquatic eco-system.

As an overdose of Iron (III) Chloride leads to a massive pollution of water, is injurious to humans and pollutes the environment, a completely dependable method of process monitoring is paramount. A continuous flow measurement of the dosing chemical with a direct data connection to your process control system guarantees you maximum safety; so that possible errors are not just discovered during sample taking, when it's too late.

Solution:

With the MIK magnetic-inductive flow meter, KOBOLD Messring GmbH offers you an optimal and economical solution for safe dosage of Iron (III) Chloride. The unit was specifically developed for this application and has already proven itself very successfully in service.

The device housing is made of PVDF, the electrodes in contact with the medium are made of tantalum. Both materials have proven to be totally chemically resistant. Together with the direct mounted transmitter with stainless steel housing, this device forms a very compact yet robust unit, which is ideal for fitting inside cramped control cabinets. It allows detection of very small dosage amounts from 10 mL/min!

With an analogue 4-20 mA signal (or optional pulse output) the MIK continuously communicates the measured values to your process control system, so that it allows immediate response to the latest process conditions.

This increases efficiency, saving cost in the amount of Iron Chloride required to achieve phosphate removal, and protection of the environment.

Automation guarantees high standards of plant safety even at unmanned plants!

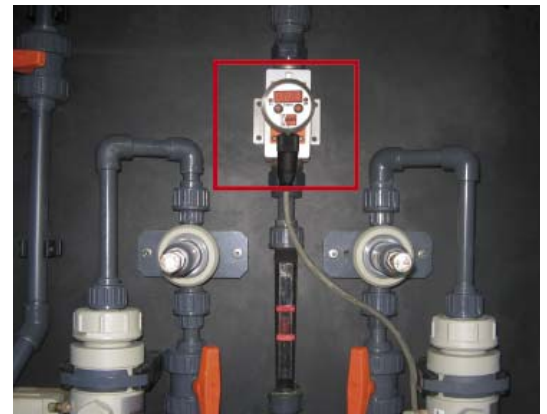

Air sparge systems for groundwater remediation

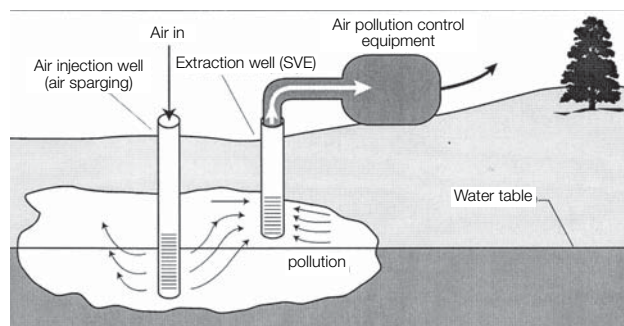

Task:

Inexpensive flowmeter to install in an air sparge field with multiple wells

Air sparging involves drilling multiple wells into a contaminated ground water pocket. Fresh air is forced into the groundwater in order to 'bubble' contaminants into the vapor pocket above the water. The contaminated air is pulled out of the pocket and treated. The sparge runs continuously until the ground water is free of contaminants.

Solution:

The customer needed an inexpensive flowmeter to install in an air sparge field (120 individual wells). The meter ensures sufficient air flow into the well. Preferred KSM series all plastic to minimize corrosion and reduce cost. We were recommended by one of the engineers in the firm due to excellent support on a past project. We were able to quickly ship 6 pieces for a test and the balance direct to site. Each sparge field uses anywhere from 100-150 meters.



The KSM is a safe and economical solution for ground water remediation monitoring!

Applications

Brewery - Instrumentation

Selected for you from the comprehensive KOBOLD product range



Flow

Measurement without moving parts

- Model DUK: Ultrasonic Flow Meter/Switch
- Model KSM: Variable Area Flow Meter/Switch
- Model PSR: Paddle Flow Switch
- Model MIK: Magnetic Inductive Flow Meter
- Model DAA/DAH: Flow Indicator

Pressure

- Model MAN-ZF: Bourdon Tube Pressure Gauge
- Model MAN-RF...DRM: All stainless steel Pressure Gauge with Diaphragm Seal, Capillary and Clamp Connection
- Model MAN-RF...M21...DRM: All stainless steel Contact Pressure Gauge with Liquid Damping, Diaphragm Seal and Dairy Connection
- Model PSC/PDD: Electronic Pressure Switch



Level

Level Switch/Meter for almost all Bulk Goods

- Model NIR: Rotary Vane Level Switch (EX)
- Model NTB: Deep-well Probe
- Model NMT: Magnetostrictive Level Gauge
- Model LNM: Microwave Level Switch
- Model LNK: Conductive Level Switch
- Model NBK: Bypass Level Gauge
- Model LNP: Potentiometric Level Meter



Temperature

- Model LTS-NK: Temperature Probe Pt 100 compact version
- Model TNS-TNF: Safety Thermometer with Contacts
- Model TDD/TDA: Electronic Temperature Sensor/Switch



Turbidity and Conductivity

- Model ATL: Turbidity Sensor
- Model ATT-K: Transmitter
- Model LCI: Inductive Conductivity Measuring System



Hand-Held Units/Data Logger

For many different variables

- Model HND-T: for Temperature Measurement
- Model HND-F: for Humidity Measurement
- Model HND-P: for Pressure Measurement
- Model HND-C: for Conductivity Measurement
- Model HND-R: for pH, Redox, Temperature Measurement
- Model ZLS: Electronic Multi-Channel Data Logger



Model	Page	Model	Page	Model	Page	Model	Page	Model	Page
ACM	34	DPT	6	LNM	28, 35	NVI	29	TRS	31
ACS	34	DRB	8	LNP	29, 35	NWS	28, 35	TSA	32
ADI	5, 8, 11-12, 14, 29, 37	DRG	11-12	LNR	28	OME	14	TSH	31
AFA	34	DRH	11	LNZ	28, 35	OMG	14	TSK	6
AFK	34	DRM	23-24, 35	LPS	6	OPT	28	TTD	33
AFS	34	DRS	7	LTS	32, 35	OVZ	13	TTE	33
APM	34	DRT	12	LZE	28-29, 32, 35	PAD	22-23, 30	TTL	33
APS	34	DRZ	12	MAN	21- 24, 35	PAS	25, 30	TTM	33
ATA/ATS	34	DSS	5	MAS	15	PDA	24	TUR	7
ATL	34	DSV	4	MFC	15	PDC	21	TUV	8
ATT	34	DTK	10	MFR	37	PDD	26	TWA	33
AUF	7-13, 17-18, 24-26, 32, 35, 37	DTM	32	MFF	37	PDL	26	TWD	32
BA	30	DUK	18-19	MFR	37	PEL	9	TWE	33
BGF	5	DVE	18	MIK	17	PIT	17	TWL	33
BGK	4	DVH	18	MSR	37	PLS	29	TWM	33
BGN	4-5, 35	DVK	15	MZB	26	PMP	22	TWP	32
BUS	37	DVZ	17-18	M	27	PNK	23	TWR	31
BVB	5	DWD	6	MS	27	PPS	6	UFJ	20
DAA/DAH	19	DWF	34	NAB	27	PSC	26	UMR/UXR	3
DAB	20	DWN	6	NAD	36	PSE	6	URA	4
DAF	19-20	DWU	6	NBA/NBE	27	PSR	6	URB	3
DAG	37	DZR	14	NBK	29-30	PUM	21	URK	4
DAK	20	EDM	9	NCW	28	RCD	16, 17	URL	3
DAR	19	FPS	6	NE	28	REG	19, 36	URM	3
DAT	20	HND	6, 22, 26, 32, 34	NEC	27	RFS	27	UTS	4
DAZ	20	KAL	15, 35	NEH	27	SCH	26	UVR/UTR	3
DF	10-11	KDF/KDG	3	NEK	28	SEN	24- 26, 35	V31	4
DFT	11	KDS	4	NES	27	SFL	9	VKA	5
DIG	20	KES	16	NEW	27	SMN	5	VKG	5
DIH	20	KFD	37	NGM	30	SMO/SMW	5	VKM	5
DKB	20	KFF	10	NGR	30	SMV	5	VKP	5
DKF	20	KFR	3	NGS	27	SWK	4	ZAL	13, 37
DMH	17, 35	KFA	36	NIR	29, 35	SZM	29	ZED	7-14, 37
DMS	15	KLP	36	NKP	27	TBE	31	ZLS	37
DMW	15	KM	32	NM	29	TBI	31	ZOD	37
DOB	13	KMT	15-16	NMC	29	TDA	31		
DOG	18	KPL	16	NMF	29	TDD	31		
DOL	13	KSK	3	NMT	29	TGK	31		
DOM	13	KSM	3	NPF	30	TGL	31		
DOP	13	KSR/SVN	3	NQ	28	TIR	31-32		
DOR	12	KSV	3	NSC	29, 35	TM	16		
DOT	9	KUG	24, 32, 36	NSE	27	TMA	32		
DOW	12	KUP	36	NSM	27	TME	16		
DPE	7-8	KUR	36	NSP	27	TMR	16		
DPL	9-10	KZA	14	NST	27	TMU	16		
DPM	9	LCI	34	NSV	28, 35	TND	31		
		LFM	12	NTB	30	TNF	31, 35		
		LNK	28, 35	NUS	17, 30	TNK	32		
				NV	27	TNS	31		

 **Argentina**
KOBOLD Instruments S.A.
Florida - Buenos Aires
☎ +54 (0) 11 4760 8300
info.ar@kobold.com

 **Austria**
KOBOLD Holding Ges.m.b.H.
Vienna
☎ +43 (0)1-786 5353
info.at@kobold.com

 **Belgium**
KOBOLD Instrumentatie NV/SA
Strombeek-Bever - Brussels
☎ +32 (0)2 267 2155
info.be@kobold.com

 **Bulgaria**
KOBOLD Messring GmbH
Sofia
☎ +359 2 9544 412
info.bg@kobold.com

 **Canada**
KOBOLD Instruments Canada Inc.
Pointe Claire - Montreal
☎ +1 514-428-8090
info.ca@kobold.com

KOBOLD Instruments Canada Inc.
Mississauga, Ontario - Toronto
☎ +1 416-482-8180
info.ca@kobold.com

 **Chile**
KOBOLD Messring GmbH
Santiago
☎ +56 (2) 665 1643
info.cl@kobold.com

 **China**
KOBOLD Instruments
Trading Co., Ltd.
Pudong - Shanghai
☎ +86 (0)21 583 645 79
info.cn@kobold.com

KOBOLD Manufacturing Co., Ltd.
Xian
☎ +86 (0)29 86210794/86211407
wang@kobold.com

KOBOLD Instruments Trading
(Shanghai) Co. Ltd.
Tianjin
☎ +86 (0)22 83719393
hou@kobold.com

KOBOLD Instruments Trading
(Shanghai) Co. Ltd.
Guangzhou
☎ +86 (0)20 38803380
zhentx@kobold.com

KOBOLD Instruments Trading
(Shanghai) Co. Ltd.
Wuhan
☎ +86 (0)27 87132425
yangjing@kobold.com

 **Czech Republic**
KOBOLD Messring GmbH
Brno
☎ +420 541 632 216
info.cz@kobold.com

 **Colombia**
KOBOLD Messring GmbH
Bogota
☎ +57 1 6161 761
info.co-bog@kobold.com

KOBOLD Messring GmbH
Cali
☎ +00 0 0000 000
info.calli@kobold.com

KOBOLD Messring GmbH
Barranquilla
☎ +00 0 0000 000
info.barranquilla@kobold.com

KOBOLD Messring GmbH
Medellin
☎ +00 0 0000 000
info.medellin@kobold.com

 **Egypt**
KOBOLD Messring GmbH
Nasr City - Cairo
☎ +202 2 273 1374
info.eg@kobold.com

 **France**
KOBOLD Instrumentation S.A.R.L.
Cergy-Pontoise Cedex - Paris
☎ +33 (0)1 34 21 91 15
info.fr@kobold.com

KOBOLD Instrumentation S.A.R.L.
Dardilly - Lyon
☎ +33 (0)4 72 16 21 94
rollin@kobold.com

 **Germany**
KOBOLD Messring GmbH
Hofheim/Taunus
☎ +49 (0)6192-299-0
info.de@kobold.com

KOBOLD Messring GmbH Werk II
Sindelfingen - Stuttgart
☎ +49 (0)7031-8677-0
maier@kobold.com

Heinrichs Messtechnik GmbH
Cologne
☎ +49 (0)221-497 08-0
info@heinrichs.eu

 **Hungary**
Kobold Unirota Kft.
Nyíregyháza
☎ +36 42 342-215
info.hu@kobold.com

 **India**
KOBOLD Instruments Pvt Ltd.
Pune
☎ +91 93 70 221 190
info.in@kobold.com

KOBOLD North India Region
New Delhi
☎ +91 95 60 028 453
delhi.in@kobold.com

 **Indonesia**
KOBOLD Messring GmbH
Cibubur-Bogor - Djakarta
☎ +62 21 849 328 59
info.id@kobold.com

 **Italy**
KOBOLD Instruments S.r.l.
Settimo M.se - Milan
☎ +39 02 33 572 101
info.it@kobold.com

 **Malaysia**
KOBOLD Instruments SDN BHD
Puchong, Selangor
☎ +60 (0)3 8065 5355
info.my@kobold.com

 **Mexico**
KOBOLD Instruments Inc.
Querétaro
☎ +52 442 295 1567
info.mx-mex@Kobold.com

 **Netherlands**
KOBOLD Instrumentatie BV
Arnhem
☎ +31 (0)26-384 48 48
info.nl@kobold.com

 **Peru**
KOBOLD Messring GmbH
Lima
☎ +51 1330 7261
info.pe@kobold.com

KOBOLD Messring GmbH
Arequipa
☎ +00 0000 0000
info.pe-arequipa@kobold.com

KOBOLD Messring GmbH
Trujillo
☎ +00 0000 0000
info.pe-trujillo@kobold.com

 **Poland**
KOBOLD Instruments Sp.z o.o.
Warsaw
☎ +48 (0)22 666 18-94
info.pl@kobold.com

 **Republic of Korea**
KOBOLD Instruments Co., Ltd.
Koyang-City, Kyounggi-do
Seoul
☎ +82 (0)31 903521-7
info.kr@kobold.com

 **Romania**
KOBOLD Messring GmbH
Bucharest
☎ +40 21 456 05 60
info.ro@kobold.com

 **Singapore**
KOBOLD Messring GmbH
Singapore
☎ +65 6227 1558-6366
info.sg@kobold.com

 **Spain**
KOBOLD Mesura S.L.U.
Badalona - Barcelona
☎ +34 (0)934 603 883
info.es@kobold.com

 **Switzerland**
KOBOLD Instruments AG
Dübendorf - Zurich
☎ +41 (0) 44-801 9999
info.ch@kobold.com

 **Taiwan**
KOBOLD Messring GmbH
Taipei City
☎ +886 (0)2 8792 6335
info.tw@kobold.com

 **Thailand**
KOBOLD Instruments Ltd.
Bangkok
☎ +66 (0)2 565 5705-6
info.th@kobold.com

 **Tunisia**
KOBOLD Messring GmbH
Tunis
☎ +216 7134 1518
info.tn@kobold.com

 **Turkey**
KOBOLD Instruments Ltd.
Istanbul
☎ +90 212 222 23 07
info.tr@kobold.com

 **United Kingdom**
KOBOLD Instruments Ltd.
Mansfield - Nottinghamshire
☎ +44 (0)1623 427 701
info.uk@kobold.com

 **USA**
KOBOLD Instruments Inc.
Pittsburgh, PA
☎ +1 412-788-2830
info@koboldusa.com
info.usa@kobold.com

KOBOLD Eastern Region
Providence, RI
☎ +1 401-829-1407
tcummins@koboldusa.com

KOBOLD Mid-Atlantic Region
Medina - Cleveland, OH
☎ +1 412-389-1111
gkeller@koboldusa.com

KOBOLD Western Region
Boulder City - Las Vegas, NV
☎ +1 602-418-4583
dgoss@koboldusa.com

KOBOLD Mid West Region
Clinton, Twp. - Detroit, MI
☎ +1 586-321-7227
tkelly@koboldusa.com

KOBOLD South-Eastern Region
Mt. Pleasant - Charleston, SC
☎ +1 843-812-1402
tkohler@koboldusa.com

 **Vietnam**
KOBOLD Messring GmbH
Ho Chi Minh City
☎ +84 (0)8 3551 0677
info.vn-hcm@kobold.com

www.kobold.com