



Automation 2016/E

isel[®] *From Components to Systems*

	GENERAL	
	MECHANICS	
	ELECTRONICS	
	SOFTWARE	
	SYSTEMS	

Business hours**Dermbach plant**

• sales, order processing and registry
Monday–Thursday 07:30 a.m. – 4:30 p.m.
Friday 07:30 a.m. – 2 p.m.

Eichenzell plant

• shipping and receiving
Monday–Thursday 7 a.m. – 3 p.m.
Friday 7 a.m. – 12:30 p.m.

Eichenzell plant

• Personal collection
Monday–Thursday 8 a.m. - 1 p.m.
Friday 8 a.m. - 11 a.m.

Switchboard

phone: +49(0) 6659 / 981-700 | telefax: +49 (0) 6659 / 981-776 | Email: automation@isel.com

Shipment: national and international

phone: +49(0) 6659 / 981-790 | telefax: +49(0) 6659 / 981-782 | Email: versand@isel.com
Doreen Goepfert -741
Ingo Giebel -746

Accounts receivable department

phone: +49(0) 6659 / 981-154 | telefax: +49(0) 6672 / 898-195 | Email: debitoren@isel.com
Doris Wolf

AUTOMATION Division**Sales and consultancy**

phone: +49(0) 6659 / 981-790
telefax: +49(0) 6659 / 981-777
Email: tech-sales@isel.com

Jürgen Balzer Stefan Koch
Steffan Gärth Christian Bley
Felix Hohmann Katja Henkel
Janina Fischer Volker Zulauf
Jessica Gatterdam
Andreas Trabert (Sales manager)

Customer support

phone: +49(0) 6659 / 981-790
telefax: +49(0) 6659 / 981-570
Email: support@isel.com

Frank Hecht
Frank Jansen
Anna Mähler
Fred Reinhard (Support manager)

Application Center

phone: +49(0) 6659 / 981-790
telefax: +49(0) 6659 / 981-564
Email: anwendungstechnik@isel.com

Thomas Grammlich
Mike Witzmann
Andreas Schaub (Application manager)

ROBOTICS Division**Sales and consultancy**

phone: +49(0) 6659 / 981-790
telefax: +49(0) 6659 / 981-776
Email: iselrobotikeurope@isel.com

Thomas Völlinger (Divisional sales manager)

Customer support

phone: +49(0) 6659 / 981-790
telefax: +49(0) 6659 / 981-776
Email: robotik-service@isel.com

Michael Raschke

Customer support hotline

phone: +49(0) 6659 / 981-756

isel Germany AG

Buergermeister-Ebert-Straße 40 | D-36124 Eichenzell | Phone +49 (0) 6659 / 981-700 | Telefax +49 (0) 6659 / 981-776
Email: automation@isel.com | www.isel.com/germany



Dear business partners,

today you receive our current catalogue „Automation 2016 / E“, together with our thanks for your interest shown in our products!

The isel group of companies is active on the market since 40 years and we resolve to placing special emphasis on being able to offer you functionality and quality at a fair price.

ICV 4030 in the new design

Our ready-to-use desktop machine ICV 4030 has been proven for years in practice and will be now presented in a completely new design. The newly designed machine door with improved hood opening allows a longer travel range in the Z-axis, and therefore a higher passage.

Financing of machines

We work closely with you to get the right financial package to suit your individual business objectives. Whether you opt for a new model or a used machine from isel: together we will draw up the finance quote that suits you.

Maintenance contract

Nobody can afford a production stoppage and we ensure the reliability of your isel product at all times. Regular maintenance by our highly qualified service technicians guarantees the greatest precision and reliability – for the lifetime of the machine. We maintain your machine in a professional, safe and reliable manner. For failsafe production on isel machines, we offer you three different maintenance packages – Standard / Comfort / Excelent – which are tailored to different production conditions. Ask your isel contact if you are interested in a maintenance package.

Service

We set great store by good service – you will therefore benefit from our free online support not just during the warranty period, but also thereafter. Our hotline allows you to contact us even outside the business hours and aims you to provide direct remedial action in the case of a problem.

Our service technicians are experienced at working on site. Training sessions at your company or in our application centre prepare you to work effectively with our products.

Fair prices and conditions

It is a priority for us to deliver our components and systems tailored to your individual requirements. For decades we are anxious to realize that with a consistently good price-/performance ratio. We are especially proud of keeping pace with the international competition with our 'Made in Germany' products. Free delivery within Germany has made deliveries a lot easier both for you and us

Global presence

With new offices in the USA, England, France, Austria and Hungary and numerous partners in Germany, Europe and globally, we are never far away.

Successful together

Our catalogue contains our time-proven and newest products and shows you a great number of different sample combinations.

If you have any questions, please do not hesitate to contact our team.

We can only benefit together, if you are successful too! I'm at your disposal for any suggestion for improvement any time.

Andreas Trabert

Sales Manager
isel Germany AG

isel Group locations in Germany



Plant Eiterfeld
36132 Eiterfeld, Hesse
total space: approx. 53,000 m²

Plant Eichenzell
36124 Eichenzell, Hesse
total space: approx. 35,000 m²



Plant Dermbach
36466 Dermbach, Thuringia
total space: approx. 41,000 m²

Plant Berlin
13627 Berlin-Charlottenburg
total space: approx. 22,000 m²



Contents

GENERAL

Contact	A-2
Welcome	A-3
Locations	A-4
Corporate philosophy	A-5
How to find us	A-6
Subsidiaries	A-7
Life Cycle Service.....	A-8
Application Center	A-10
Reference	A-11
Quality assurance	A-12

MECHANICS

Linear guides	B-2
Drive elements	B-32
Linear units	B-42
Rotational units	B-88

ELECTRONICS

Motors	C-4
Sensors	C-12
Controllers	C-14

SOFTWARE

CAD / CAM	D-4
Interpreter software	D-6
Programming software	D-7

SYSTEMS

CNC machines	E-4
Accessories	E-22
Robotics	E-44

The isel-Group

The international [isel group of companies](#) was founded in 1972 as a one-man operation in Eiterfeld (Hesse) under the company name isert electronics. The company dealt with the manufacture and distribution of equipment "around the conductor board" in the first few years. Object of the company today is the development, production, sales and service of components and systems for automation.

The product range from components to systems made by isel includes CNC units, CNC machines, automation, handling and robotics with step, servo, linear and torque motors including controls.

Members in Germany are the companies isel GmbH & Co.KG, **isel Germany AG**, imes-icore GmbH and isel Facility GmbH. Other offices are located in Austria, Hungaria, France, Great Britain and the USA.

isel Gemany AG

The [isel Germany AG](#) is a hundred percent company of the isel group and located in Germany in Eichenzell (Hesse) and Dermbach (Thuringia) with a total of **25,000 m²** of production, warehouse and office space.

Main area of business of the isel Germany AG is the provision of components from MECHANICS, ELECTRONICS and SOFTWARE. Furthermore CNC units and CNC machines are available with extensive accessories. This includes also commissioned work and project planning for OEM customers in all sectors.

In addition to an expert advice, the isel Germany AG also offers services like trainings and project planning.

Benefit from our years of experience on the market! We deliver from components to system from a single source.

Technical data is accurate to the best of our knowledge and belief. Future developments are subject to change without notice. This catalogue supersedes all previous versions.

How to find us

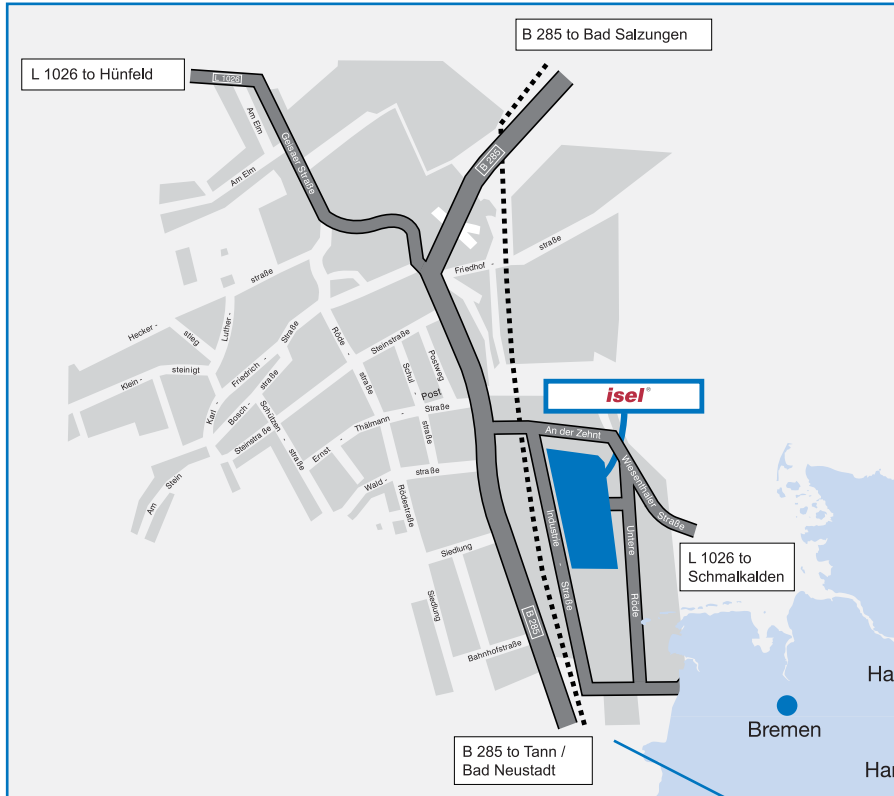

You can find us in the heart of Germany.

Dermbach is located at the B 285 between Bad Neustadt/ Saale and Bad Salzungen, respectively at the L 1026 between Hünfeld and Schmalkalden.

Dermbach

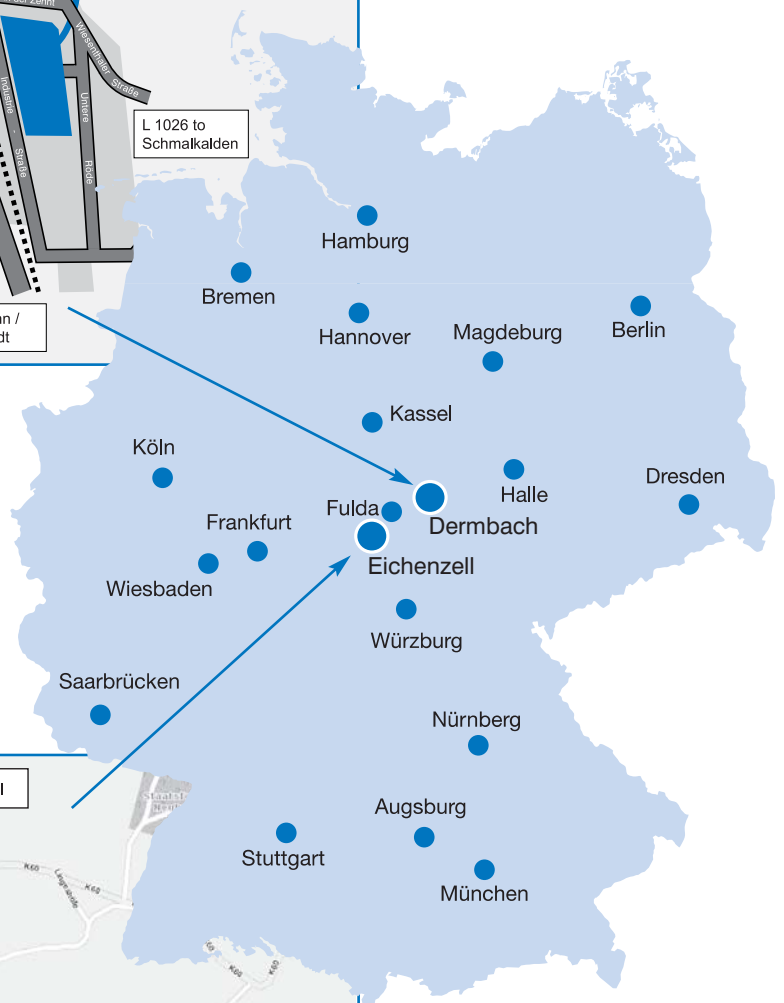

Eichenzell

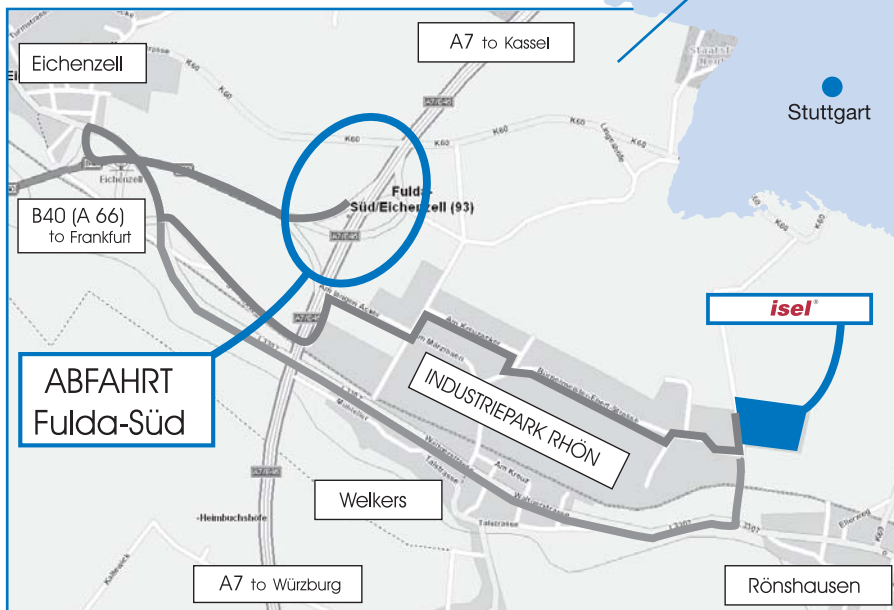

Eichenzell is located at the A7 between Kassel and Würzburg, exit Fulda-Süd, if you are coming from Frankfurt at the A 66/B 40.

Subsidiaries international



isel Austria

isel Austria GmbH & Co.KG
Maria Theresia-Str. 53 / 1.1
4600 Wels / Austria

Phone: +43 (0) 7242 206829
Telefax: +43 (0) 7242 211445

Website: www.isel.com/at/
Mail: info@isel-austria.com

Sales for:

GUS states (Russia), Poland, Estonia, Latvia, Lithuania, Ukraine, Belarus, Moldova, Kazakhstan and Georgia



isel Hungária

isel Hungaria Kft.
József A. utca 38
H-8200 Veszprém

Phone: +36 (0) 88 406 682
Telefax: +36 (0) 88 406 681

Website: www.isel.hu
Mail: iselhungaria@isel.hu

Sales for:

Bulgaria, Serbia, Montenegro, Bosnia and Herzegovina, Croatia, Slovenia, Slovakia, Czech Republic and Romania



isel France

isel-France
ZAC de la Prévauté
4, Rue des Côtes d'Orval BP41
F-78550 Houdan

Phone: +33 (0) 130 461 201
Telefax: +33 (0) 130 596 932

Website: www.isel.fr
Mail: info@isel.fr

Sales for:

France



isel UK

isel UK Ltd.
Unit 17 | Maylands Business Centre
Redbourn Road
Hemel Hempstead | HP2 7ES
United Kingdom

Phone: +44 (0) 1442 531 225
Mobil: +44 (0) 7821 761 517

Website: www.isel.com/uk/
Mail: info@isel-uk.com

Sales for:

Great Britain and Ireland



isel USA

isel USA, Inc.
69 Bloomingdale Road
USA, Hicksville, New York 11801

Phone: 001-516-595-7497

Website: www.techno-isel.com
Mail: George.klein@isel.com
Joseph.Griffin@isel.com

Sales for:

USA, Mexico and Canada

Life Cycle Service

... to ensure, that you can use your CNC machine every day without any worries



Maintenance



Reconditioning

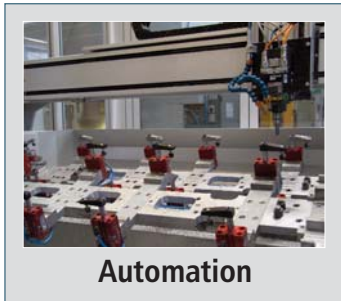

Automation



Measurement / testing

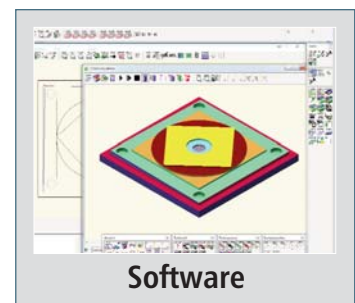

Software

Life Cycle Service

... to ensure, that you can use your CNC machine every day without any worries

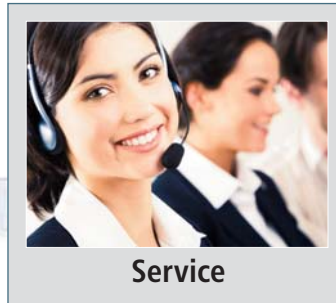

Service



Spare parts



Retrofitting



Training

Application Center



Visit our factory in Dermbach, Thuringia and convince yourself on-site of the efficiency of our cnc machines. We like to draw your attention to present a cross-section of our range of products, furthermore we offer you the opportunity of practically orientated demonstrations.

Do you have any questions regarding specific topics concerning particular applications? Don't hesitate to arrange an appointment with our applications technologist **Andreas Schaub**.

Mr. Andreas Schaub
phone: +49 (0) 36964 / 84 525
anwendungstechnik@isel.com

In our showroom, you'll find the following machines:

- ICV 4030
- FlatCom M
- EuroMod MP65
- ICP 4030
- OverHead
- FlatCom XL



References



Daimler AG



Vision Systeme



Quality Services GmbH



Daimler AG



Quality assurance according to DIN ISO 9001:2008

The quality assurance system for our products comprises all areas which contribute to achieving the quality goals. It is based on legal requirements, customer requirements and the internal isel Germany AG quality requirements. The quality assurance system ensures the production processes are manageable and that products are only sent on to the next production step if they meet the respective specifications. We are certified according to DIN ISO 9001:2008.



Coordinate measuring equipment

Mitutoyo CRYSTA Apex S 123010

Specifications: X-axis = 1,205 mm
Y-axis = 3,005 mm
Z-axis = 1,005 mm

Touch system: TP 200
Changer magazin: SCR 200
Length measuring deviation:
MPE = $(2,5 + 4,0L/1000)\mu\text{m}$



Mitutoyo Euro C 544 Apex

Specifications: X-axis = 500 mm
Y-axis = 400 mm
Z-axis = 400 mm

Touch system: TP 200
Changer magazin: SCR 200
Length measuring deviation:
MPE = $(2,9 + 4,0L/1000)\mu\text{m}$



Mitutoyo Euro C 574 Apex

Specifications: X-axis = 500 mm
Y-axis = 700 mm
Z-axis = 400 mm

Touch system: TP 200
Changer magazin: SCR 200
Length measuring deviation:
MPE = $(2,9 + 4,0L/1000)\mu\text{m}$



Technical specifications subject to change.

... and the quality requirements of our customers and isel Germany AG



Surface roughness tester
Mitutoyo

Type: SJ - 201 P

Test procedure: Ra, Ry, Rz, Rq, Rt



Hardness tester
Wolpert

Type: Dia
Testor 2 Rc

Test procedure: Vickers, Brinell and Rockwell



Layer thickness measurement device
Elektro Physik

Type: Minitest 600 B

Probe for iron and non-iron measurements.

QC 10 accuracy check

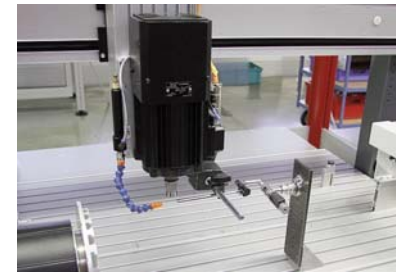
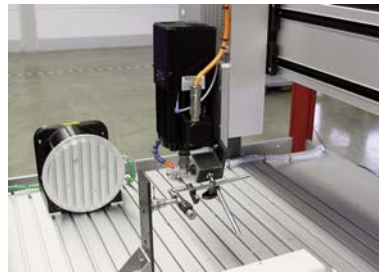
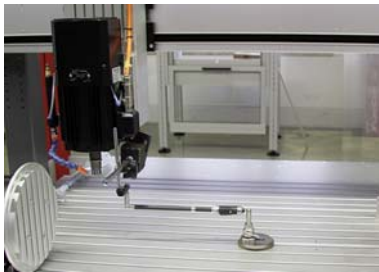

The QC 20 system allows the routine inspection of our machines. The measurement of the circularity detects geometric and control machine faults such as for example squareness, contouring errors, guide clearance, straightness faults and backlash. The system is traceable and is checked by the manufacturer on a regular basis.

XL-80 Laser Interferometer

We use the laser system for calibrating machine tools and coordinate measuring equipment for ...

... position measurement

Position measurement is the most common measurement performed on machines. The system captures the positioning and repeat accuracy by comparing the position value indicated by the machine and the actual position captured by the Laser Interferometer System.

... tilt angle measurement

On machine tools and coordinate measuring equipment the cause for positioning faults is oftentimes the tilt of the axis. With the Abbe effect the faults continue to increase with an increasing distance from the axle location.

... Measuring the dynamic behaviour

The software for dynamic measurements allows for motion sequences, speeds, accelerations, vibrations and the capabilities of servo drives to be determined.

... Measuring the straightness

The straightness measurement is used to determine the horizontal and vertical straightness of the guide of the machine. Straightness errors have a direct influence on the positioning and the path accuracy of the machine.



Technical specifications subject to change.

mechan

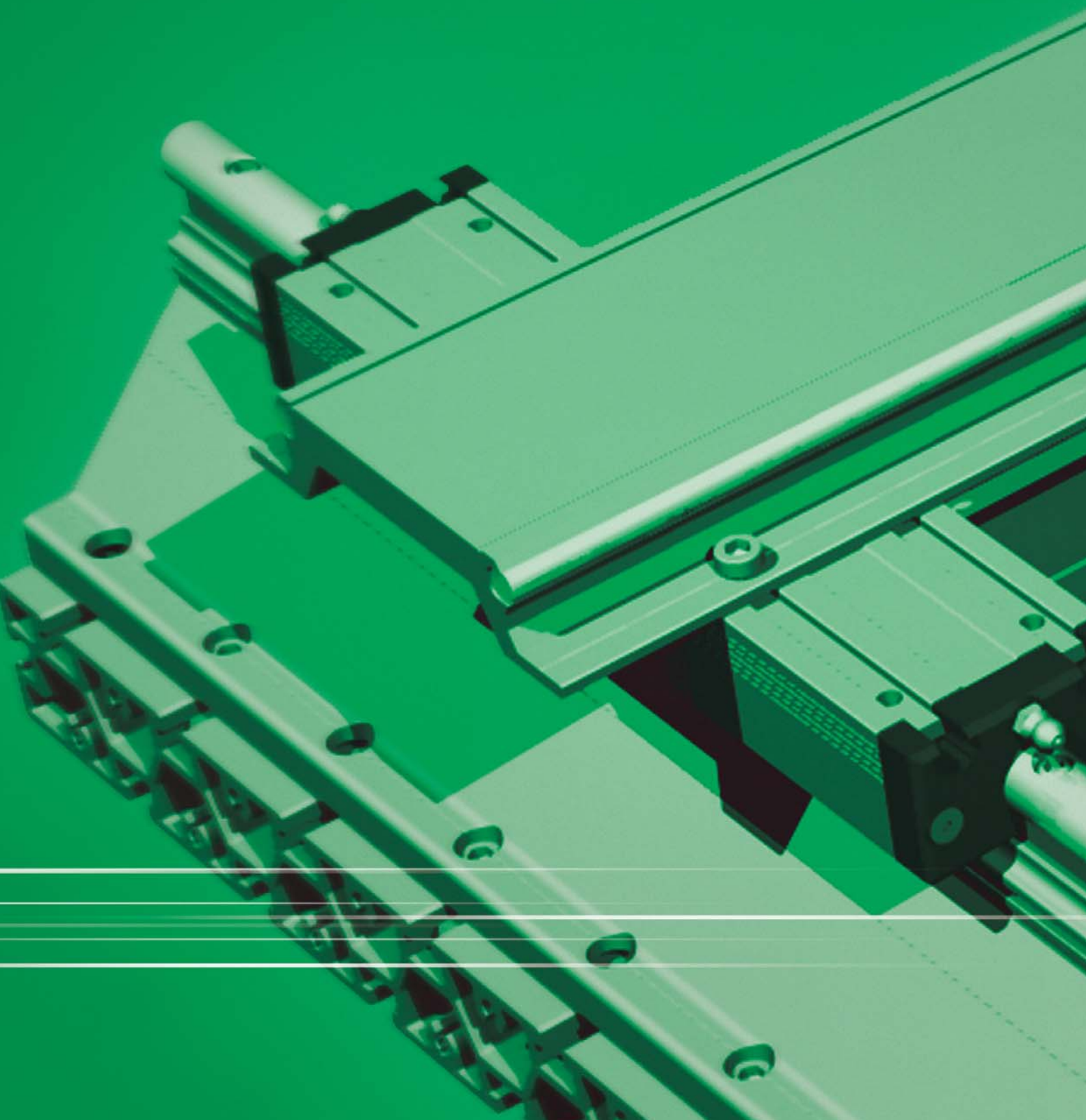

mechanics



MECHANICS

Linear guidesB-2









Drive elementsB-32

Linear unitsB-42

Rotational unitsB-88

Linear guides

Overview

<p>Slides functional overview General notes</p>		<p>B-4</p>
<p>LFS-8-1 Linear guide rails LFS-8-2</p>		<p>B-6 with LW 6 trolley with WS 1 aluminium slide</p>
<p>LFS-8-3 Linear guide rails</p>		<p>B-8 with LW 7 trolley with WS 3 aluminium slide</p>
<p>LFS-8-4 Linear guide rails</p>		<p>B-10 with LW 7 trolley with WS 3 aluminium slide</p>
<p>LFS-8-7 Linear guide rails</p>		<p>B-12 with LW 10 trolley with WS 11/70 aluminium slide</p>
<p>LFS-12-1 Linear guide rails</p>		<p>B-14 with LW 3 trolley with WS 4 aluminium slide with LS 1 steel slides</p>
<p>LFS-12-11 Linear guide rails</p>		<p>B-16 with LW 5 trolley with WS 6 aluminium slide</p>
<p>LFS-12-2 Linear guide rails</p>		<p>B-18 with LW 3 trolley with WS 4 aluminium slide</p>

Linear guides

Overview

LFS-12-3 Linear guide rails



with LW 2 trolley
with LW 8 trolley
with WS 7 aluminium slide

B-20

LFS-12-10 Linear guide rails



with LW 4 trolley
with WS 8 aluminium slide
with dual track set 1 + 2

B-22

LFS-16-120 Linear guide rail



with 2 or 4 IWS 1 aluminium slide
with 2 or 4 ILS 1 steel slides

B-24

LSK Linear guide rail



in 15, 20, 25 and 30 size

B-26

Accessories

B-28

Operating loads calculation

B-29

CAD data can be found on



Linear guide slide function

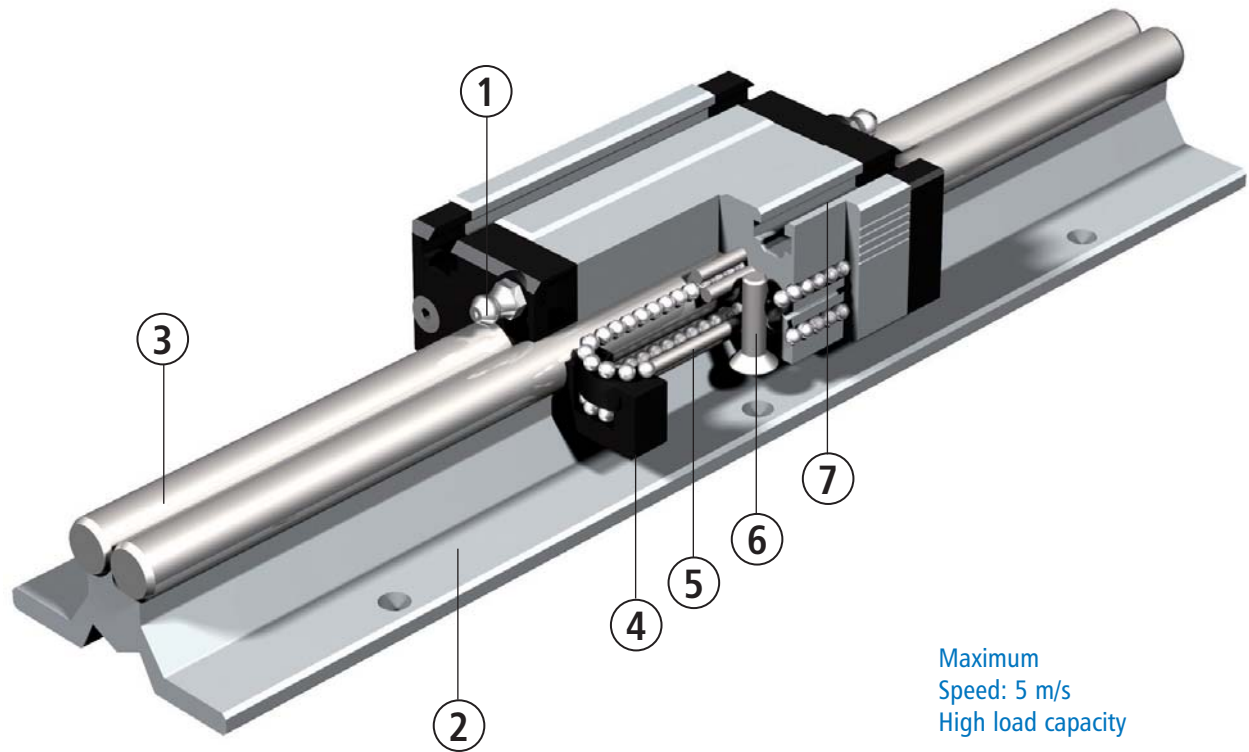

Maximum
Speed: 5 m/s
High load capacity

Aluminium shaft slides

The shaft slides from isel are perfectly suited for assembling of complex multiple axis systems for handling and machining.

The wide range of models covers a multitude of applications.

All models can be produced to order with various profile lengths (70, 100, 150 and 200 mm).

1. Lubrication options to both sides for the recirculating balls.
2. The basic supports for all linear guides are extruded aluminium profiles compliant with DIN EN 12020-2, which are provided with T-slot inserts for fastening in the body of the profile or with drilled hole fixing points.
3. Precision steel shafts with a hardness of 60 ± 2 HRC are used as guide rails. All LFS-8 versions are optionally available with stainless steel shafts.
4. The recirculating ball steering systems are glass fibre reinforced.
5. There are recirculating balls in the linear slide. Ball bearings run in each case between two ground steel pins and the guidance shaft.
6. The slide is adjusted with self-locking setting screws. This is how the rows of balls and shafts or pins are used with each other and thus prestressed. The slide are preset in the factory to the correct stress. All shaft slides are optionally available in a stainless version.
7. To secure transport loads, slot plates, etc., the shaft slide are provided with T-slot inserts or fixing borings.

General notes

Load capacity and working life

Installation site

In principal, the installation site for linear guides can be chosen anywhere. You merely have to consider whether all the forces and moments arising are below the maximum values for the relevant axes.

Temperatures

All linear guides are designed for continuous operation at ambient temperatures of up to 60 °C. In short-term operation, maximum temperatures of 80 °C are permissible.

Linear guides are unsuitable for temperatures below freezing.

Straightness/Warping

The aluminium profiles used are extruded profiles, which exhibit divergences regarding straightness and may be warped, owing to the manufacturing process.

The tolerance of this deviation is set out in DIN EN 12020-2.

In the worst case, the linear guide deviations equal these limits, but typically they are lower.

In order to achieve the desired guidance accuracy, the guide must be aligned using shims or clamped to a bearing service machined to the corresponding accuracy. This achieves tolerances of 0.1 mm/1000 mm.

Principles

Load capacity and working life

The dimensioning of a linear guide is based on the load capacity of the individual elements. The load capacity is described by:

- the dynamic load factor C
- the static load factor C0
- the static torques MOX, MOY and MOZ

The basis of the dynamic load factors according to DIN is a nominal working life of 100,000 m displacement path. Far East suppliers often quote load factors for a nominal working life of 50,000 m displacement path; this produces load factor figures which are approximately 20% higher than those according to DIN.

Dynamic load capacity

The fatigue characteristics of the material determine the dynamic load capacity. The working life - the fatigue period - also depends on:

- the stress on the linear guide
- the speed at which the linear guide moves
- the statistical randomness of the first damage occurring

Useful life

Useful life means the working life actually achieved by a linear guide. The useful life may differ from the computed working life.

The following can lead to premature failure through wear or fatigue:

- Misalignments between guide rails or guidance elements
- Contamination of the guide rails
- Insufficient lubrication
- Oscillating motion with very small lifts (formation of grooves)
- Vibrations at rest (formation of grooves)

Owing to the multiplicity of installation and operating relationships, it is impossible to determine the useful life of a linear guide exactly in advance. The safest way to make an accurate estimate of the useful life is, as before, a comparison with similar installations.

Linear guide rails

LFS-8-1 LFS-8-2



Figure:
LFS-8-1 with
aluminium slide WS 1/70

Figure:
LFS-8-2 with
aluminium slide WS 1/70

Features

- W 30 x H 20 mm (LFS-8-1)
W 30 x H 32.5 mm (LFS-8-2)
- 2 precision steel shafts Ø 8
- Anti-twist lock
- Aluminium shaft housing profile, naturally anodised
- Fixing from below with M6 tapped rails in the T-key insert
- Conditionally self-supporting
- Special lengths to order
- Weights: approx. 1.6 kg/m (LFS-8-1)
approx. 2.0 kg/m (LFS-8-2)

Options:

- Stainless steel version
- Drilled for M6 (LFS-8-1 only)

Ordering key

235 00X XXXX

LFS-8-1 / standard = 0	Length LFS-8-1	Length LFS-8-2
LFS-8-1 / stainless = 1	in mm (in a grid of 100 mm)	in mm (in a grid of 100 mm)
LFS-8-2 / standard = 2	e.g. 0029 = Length 298	e.g. 0298 = Length 298
LFS-8-2 / stainless = 3	0299 = Length 2998	2998 = Length 2998

Steel shaft length: total length L - 3 mm
Profile up to 6000 mm available without impact connection, steel shafts divided.

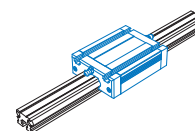

Aluminium slide

- With recirculating ball guide
- Clamping surface plane milled
- M6 T-key inserts
- Central lubrication option
- Adjustable for no play
- Option: stainless steel version

Load data

Shaft slide WS 1/70	
C ₀	3114 N
C	1846 N
F ₁ static	2659 N
F ₁ dynamic	1576 N
F ₂ static	3114 N
F ₂ dynamic	1846 N
M _x static	37.3 Nm
M _y static	100.5 Nm
M _z static	117.6 Nm
M _x dynamic	22.1 Nm
M _y dynamic	59.5 Nm
M _z dynamic	69.7 Nm

Shaft slide WS 1	
C ₀	4590 N
C	2390 N
F ₁ static	3920 N
F ₁ dynamic	2041 N
F ₂ static	4590 N
F ₂ dynamic	2390 N
M _x static	55.0 Nm
M _y static	148.1 Nm
M _z static	173.4 Nm
M _x dynamic	28.6 Nm
M _y dynamic	77.1 Nm
M _z dynamic	90.2 Nm

Trolley LW 6	
C ₀	2160 N
C	4000 N
F ₁ static	4320 N
F ₁ dynamic	3792 N
F ₂ static	2160 N
F ₂ dynamic	4000 N
M _x static	121.1 Nm
M _y static	194.4 Nm
M _z static	97.2 Nm
M _x dynamic	106.3 Nm
M _y dynamic	170.6 Nm
M _z dynamic	180.0 Nm

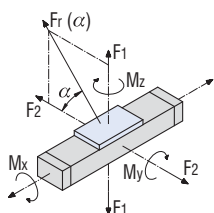

$$Fr(\alpha) = \frac{F_2}{\cos \alpha}$$

$$Fr(\alpha) = \frac{F_1}{\sin \alpha}$$

L 96 x W 72 x H 28.5 mm (WS 1/70)
(weight: approx. 0.4 kg)

Part no.: **223100 0070**
Stainless steel: **223101 0070**

L 126 x W 72 x H 28.5 mm (WS 1)
(weight: approx. 0.5 kg)

Part no.: **223100**
Stainless steel: **223101**

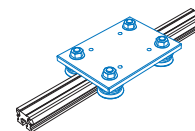

Trolley LW 6

- L 125 x W 90 x H 7.7 mm
- ground steel plate
- 4 rollers Ø 31, sealed for life
- adjustable for no play
- weight: approx. 1 kg

Part no.: **223011**

Linear guide rails

LFS-8-1 LFS-8-2

Bending

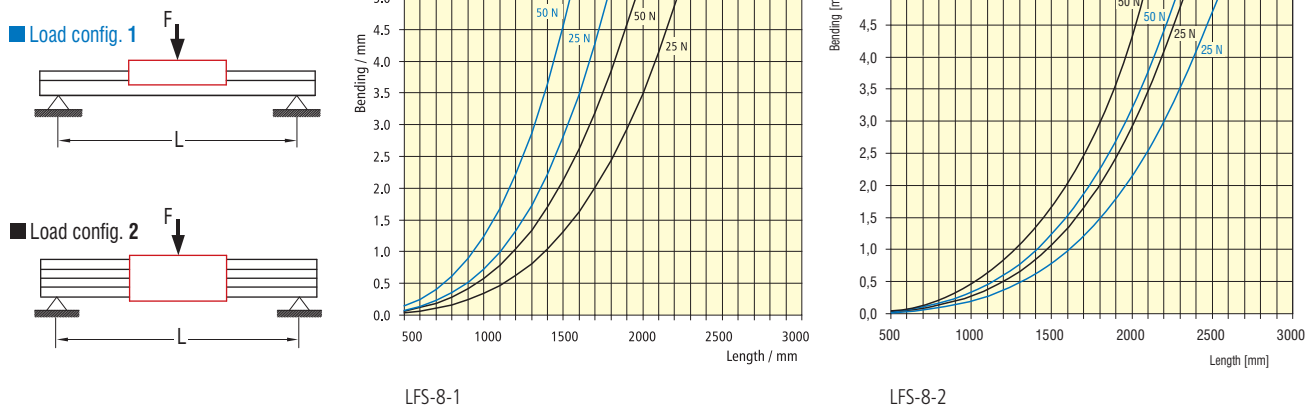

Dimensioned drawings

LFS-8-1 or LFS-8-2 with aluminium slide WS 1/70 or WS 1

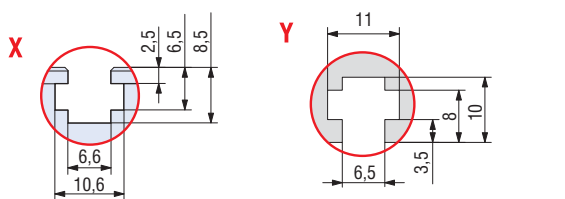
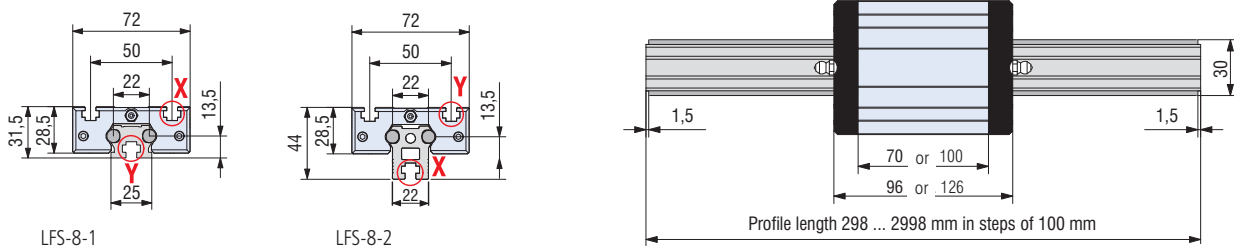

LFS-8-1 or LFS-8-2 with trolley LW 6

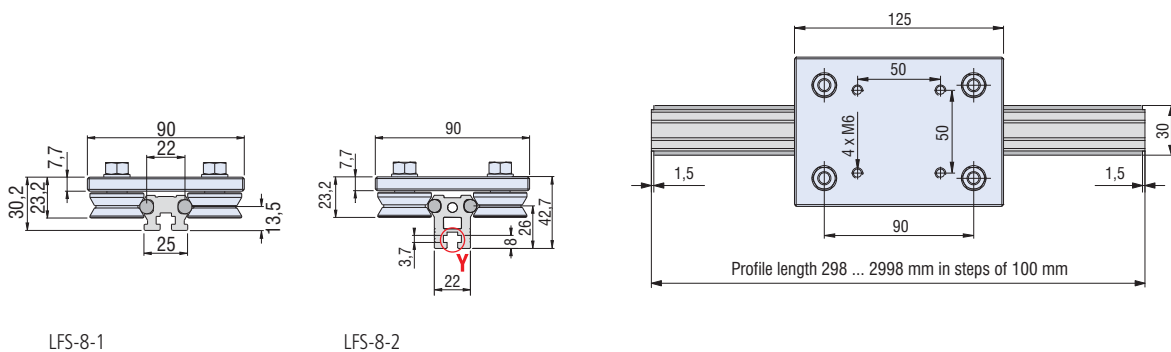

Linear guide rails

LFS-8-3



Features

- W 115 x H 25.5 mm
- 2 precision steel shafts Ø 8
- Particularly resistant to twisting
- Aluminium shaft housing profile, naturally anodised
- Fixing from above through M6 drillings in the raster 100 mm
- Conditionally self-supporting
- Special lengths to order
- Weight: approx. 3.2 kg/m
- Option: stainless steel version

Ordering key

235 00X XXXX

Standard = 4 Length in mm (in 100 mm raster)
 Stainless = 5 e.g. 0029 = Length 296
 0299 = Length 2996

Length overall L - 1 mm

Profile up to 6000 mm available without impact connection, steel shafts divided.

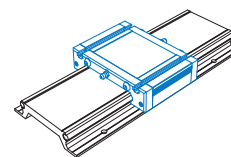

Aluminium slide

- With recirculating ball guide
- Clamping surface plane milled
- M6 T-key inserts
- Central lubrication option
- Adjustable for no play
- Option: stainless steel version

L 96 x W 130 x H 32 mm (WS 3/70)
 (weight: approx. 0.5 kg)

Part no.: **223103 0070**
 Stainless steel: **223103 1070**

L 176 x W 130 x H 32 mm (WS 3)
 (weight: approx. 0.9 kg)

Part no.: **223103**
 Stainless steel: **223103 1000**

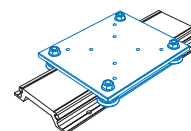

Trolley LW 7

- L 175 x W 150 x H 7.5 mm
- ground steel plate
- 4 rollers Ø 31, sealed for life
- adjustable for no play
- weight: approx. 2 kg

Part no.: **223012**

Load data

Shaft slide WS 3/70	
C ₀	3141 N
C	1879 N
F ₁ static	2682 N
F ₁ dynamic	1604 N
F ₂ static	3141 N
F ₂ dynamic	1879 N
M _x static	115.7 Nm
M _y static	105.3 Nm
M _z static	123.3 Nm
M _x dynamic	69.2 Nm
M _y dynamic	62.9 Nm
M _z dynamic	73.7 Nm

Shaft slide WS 3	
C ₀	6945 N
C	3190 N
F ₁ static	5931 N
F ₁ dynamic	2724 N
F ₂ static	6945 N
F ₂ dynamic	3190 N
M _x static	255.9 Nm
M _y static	232.8 Nm
M _z static	272.5 Nm
M _x dynamic	117.5 Nm
M _y dynamic	106.9 Nm
M _z dynamic	125.1 Nm

Trolley LW 7	
C ₀	2160 N
C	4000 N
F ₁ static	4320 N
F ₁ dynamic	3792 N
F ₂ static	2160 N
F ₂ dynamic	4000 N
M _x static	246.8 Nm
M _y static	302.4 Nm
M _z static	151.2 Nm
M _x dynamic	216.7 Nm
M _y dynamic	265.4 Nm
M _z dynamic	280 Nm

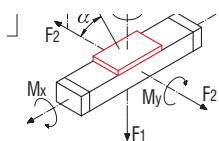

$$\sin \alpha$$

Linear guide rails

LFS-8-3

Bending

■ Load config. 1

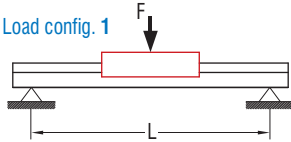

■ Load config. 2

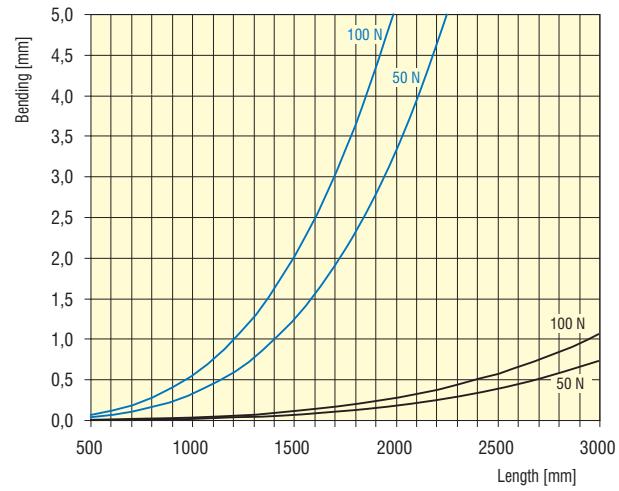
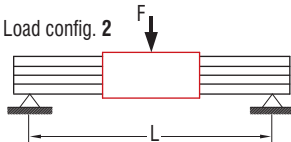

Dimensioned drawings

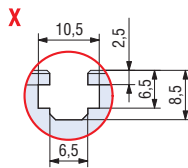
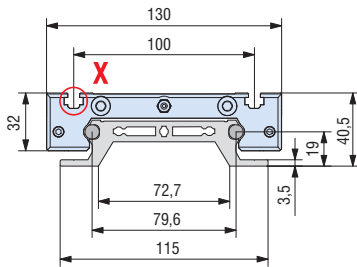

LFS-8-3 with aluminium slide WS 3/70 or WS 3

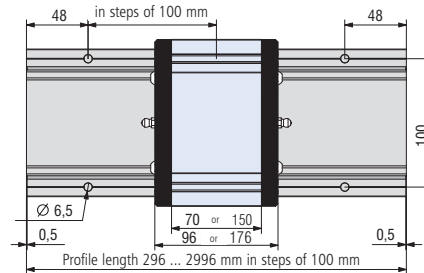

LFS-8-3 with trolley LW7

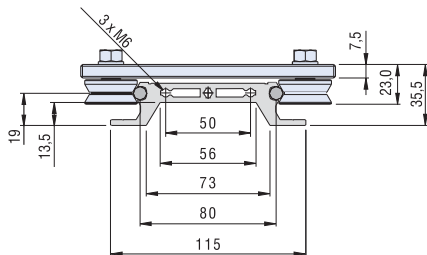
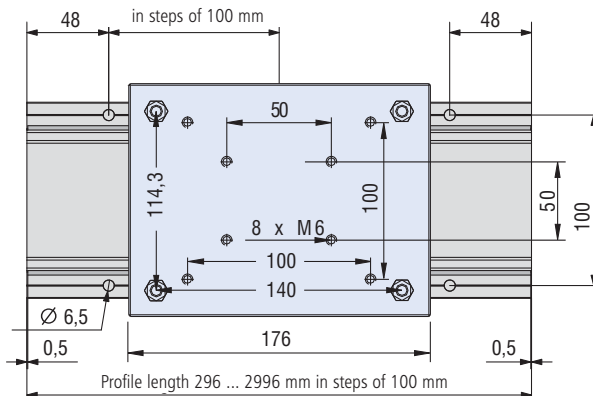

Linear guide rails

LFS-8-4

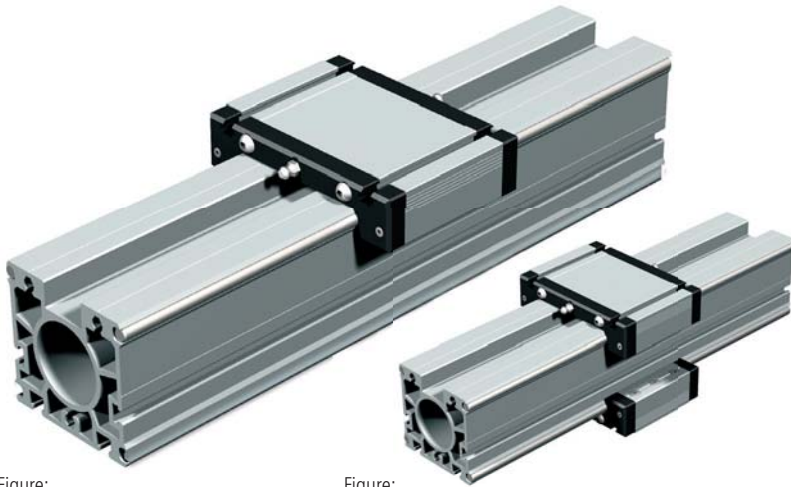

Figure:
LFS-8-4 with 2 steel shafts
and an aluminium slot

Figure:
LFS-8-4 with 4 steel shafts
and two aluminium slide (optional)

Features

- W 80 x H 80 mm
- 4 precision steel shafts Ø 8
- anti-twist
- aluminium shaft housing profiles, naturally anodised
- fixing from below with M6 tapped rails in the T-slot inserts or in the head side through M8 drillings
- side T-key inserts for limit switch securing
- conditionally self-supporting
- special lengths to order
- weight: approx. 7.2 kg/m
- options: stainless steel version with 2 steel shafts 2 slide or trolley

Ordering key

235 00X XXXX

Standard = 6 Length in mm (in 100 mm raster)
 Stainless = 7 e.g. 0029 = Length 298
 0299 = Length 2998

Steel shaft length: total length L - 3 mm

Profile up to 6000 mm available without impact connection, steel shafts divided.

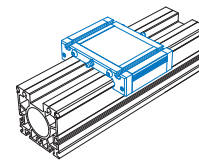

Aluminium slide

- Clamping surface plane milled
- M6 T-slot inserts
- Central lubrication option
- Adjustable for no play
- Option: stainless steel version

L 96 x W 130 x H 32 mm (WS 3/70)
 (weight: approx. 0.5 kg)

Part no.: **223103 0070**
 Stainless steel: **223103 1070**

L 176 x W 130 x H 32 mm (WS 3)
 (weight: approx. 0.9 kg)

Part no.: **223103**
 Stainless steel: **223103 1000**

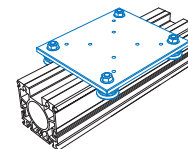

Trolley LW 7

- L 175 x W 150 x H 7.5 mm
- ground steel plate
- 4 rollers Ø 31, sealed for life
- adjustable for no play
- weight: approx. 2 kg

Part no.: **223012**

Load data

Shaft slide WS 3/70	
C ₀	3141 N
C	1879 N
F ₁ static	2682 N
F ₁ dynamic	1604 N
F ₂ static	3141 N
F ₂ dynamic	1879 N
M _x static	115.7 Nm
M _y static	105.3 Nm
M _z static	123.3 Nm
M _x dynamic	69.2 Nm
M _y dynamic	62.9 Nm
M _z dynamic	73.7 Nm

Shaft slide WS 3	
C ₀	6945 N
C	3190 N
F ₁ static	5931 N
F ₁ dynamic	2724 N
F ₂ static	6945 N
F ₂ dynamic	3190 N
M _x static	255.9 Nm
M _y static	232.8 Nm
M _z static	272.5 Nm
M _x dynamic	117.5 Nm
M _y dynamic	106.9 Nm
M _z dynamic	125.1 Nm

Trolley LW 7	
C ₀	2160 N
C	4000 N
F ₁ static	4320 N
F ₁ dynamic	3792 N
F ₂ static	2160 N
F ₂ dynamic	4000 N
M _x static	246.8 Nm
M _y static	302.4 Nm
M _z static	151.2 Nm
M _x dynamic	216.7 Nm
M _y dynamic	265.4 Nm
M _z dynamic	280 Nm

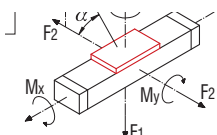

$$\sin \alpha$$

Linear guide rails

LFS-8-4

Bending

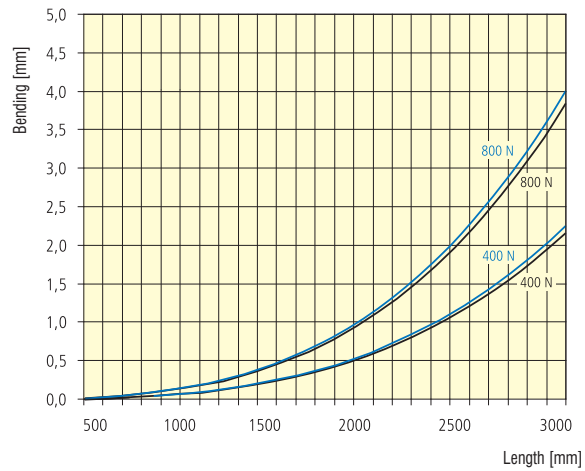
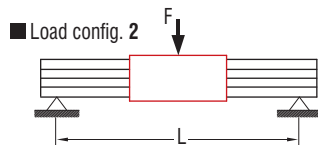
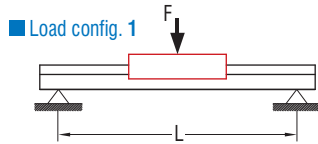

Dimensioned drawings

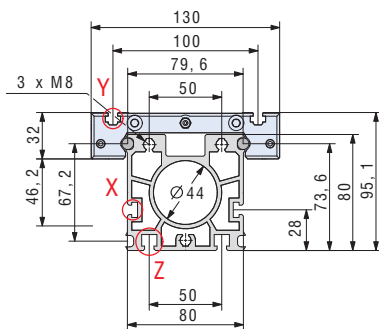

LFS-8-3 with aluminium slide WS 3/70 or WS 3

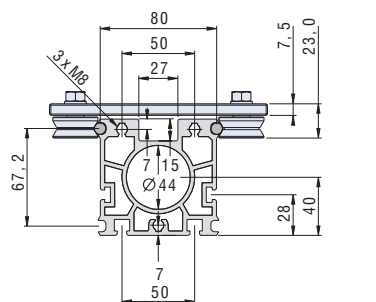
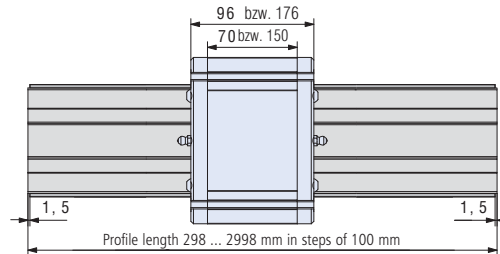

LFS-8-4 with trolley LW 7

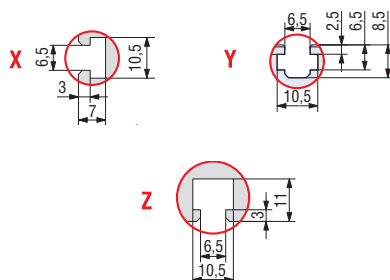
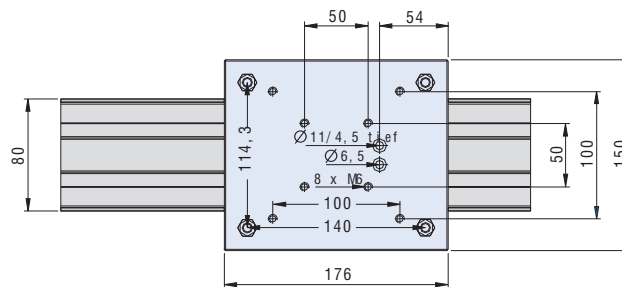

Linear guide rails

LFS-8-7

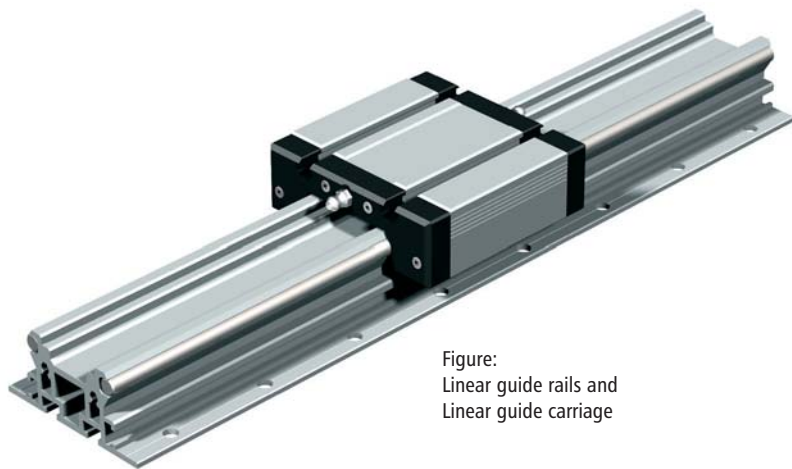

Figure:
Linear guide rails and
Linear guide carriage

Features

- W 78 x H 36 mm
- 2 precision steel shafts Ø 8 mm mounting grid 100 mm
- shaft housing contour (terminal connection)
- aluminium profile rail with T-slots, natural anodized
- conditionally cantilevered
- Standard length 3 m, segmentable at will
- weight: 2,9 kg/m
- Optionen: other lengths

Ordering key

235 012 XXXX

Length in mm (in a grid of 100 mm)

e.g. **0019** = Length 196

0299 = Length 2996

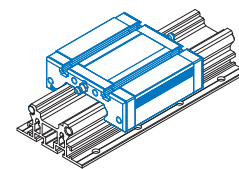

Aluminium slide WS 11/70

- Aluminium slide with 8 steel inserts L 96 x W 96 x H 32 mm
- 4 ball circuits, adjustable for no play
- Grease nipple frontally
- Weight: 0.40 kg

Part no.: **223111 0070**

Load data

Shaft slide WS 11/70	
C ₀	3114 N
C	1846 N
F ₁ static	2659 N
F ₁ dynamic	1576 N
F ₂ static	3114 N
F ₂ dynamic	1846 N
M _x static	67.3 Nm
M _y static	100.5 Nm
M _z static	117.6 Nm
M _x dynamic	39.9 Nm
M _y dynamic	59.5 Nm
M _z dynamic	69.7 Nm

Trolley LW 10	
C ₀	2160 N
C	4000 N
F ₁ static	4320 N
F ₁ dynamic	3792 N
F ₂ static	2160 N
F ₂ dynamic	4000 N
M _x static	170.4 Nm
M _y static	248.4 Nm
M _z static	124.2 Nm
M _x dynamic	149.5 Nm
M _y dynamic	218.0 Nm
M _z dynamic	230.0 Nm

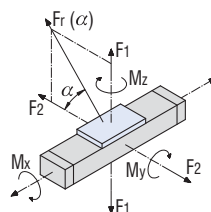

$$Fr(\alpha) = \frac{F_2}{\cos \alpha}$$

$$Fr(\alpha) = \frac{F_1}{\sin \alpha}$$

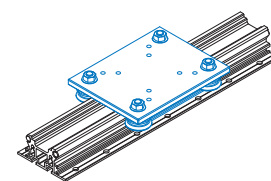

Trolley LW 10

- L 150 x W 115 x H 7,7 mm
- Grounded steel plate
- 4 castors Ø 31 mm
- Lubricated for life
- Adjustable for no play
- Weight: 1.47 kg

Part-no.: **223 014**

Linear guide rails

LFS-8-7

Bending

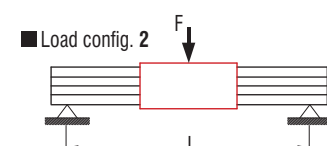
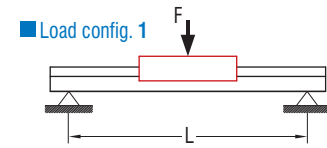
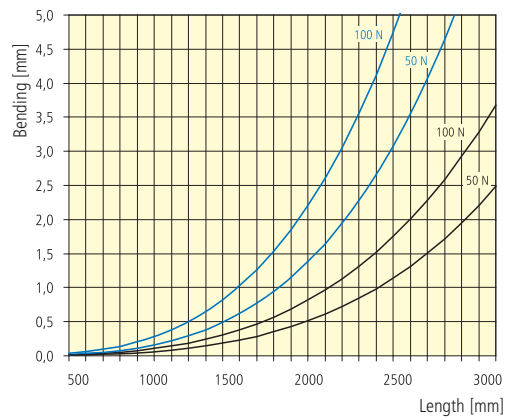

Dimensioned drawings

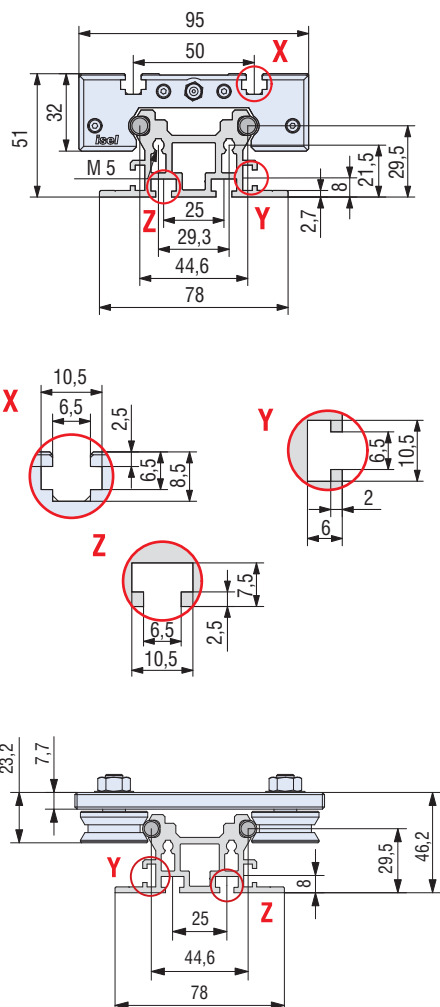

LFS-8-7 with shaft slide WS 11/70

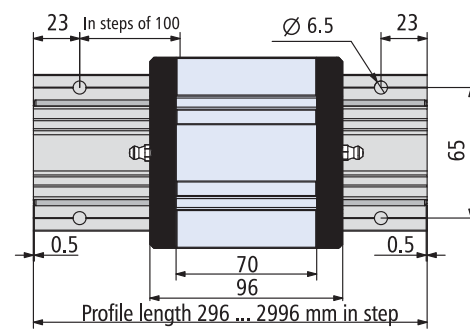

LFS-8-7 with trolley LW10

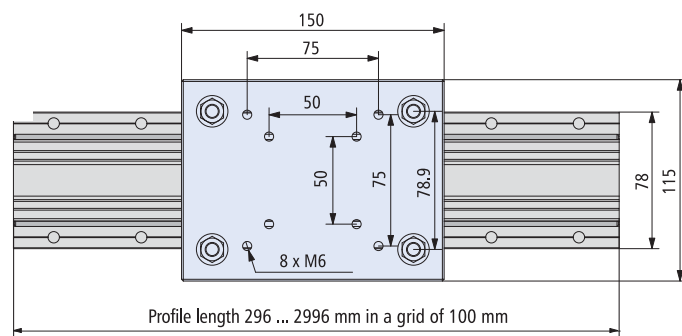

Linear guide rails

LFS-12-1

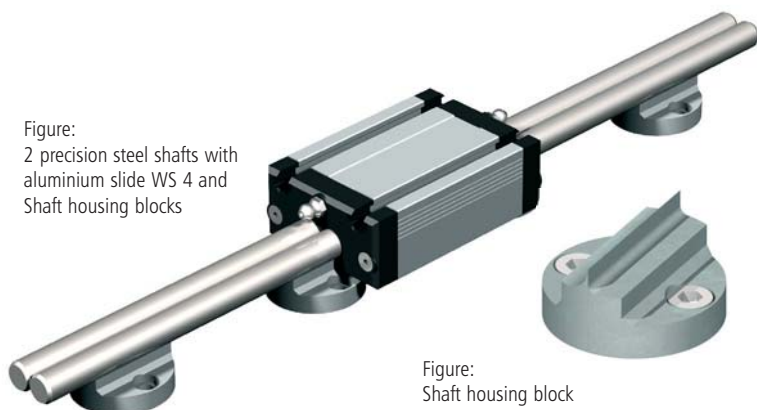

Figure:
2 precision steel shafts with
aluminium slide WS 4 and
Shaft housing blocks

Figure:
Shaft housing block

Features

- W 40 x H 27 mm
- 2 precision steel shafts Ø 12
- anti-twist
- aluminium shaft housing blocks
- securing from above or below with M6 drillings in the housing blocks
- guide any length up to 3m
- special lengths to order
- weight: approx. 1.9 kg/m

Ordering key

227 312 XXXX

Length in mm (in 100 mm raster)
e.g. **0298** = Length 298
2998 = Length 2998

Special lengths to order

N.B.!
The part no. refers to one steel shaft only !

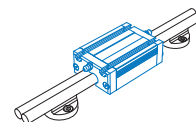

Aluminium slide

- clamping surface plane milled
- adjustable for no play
- option: stainless steel version

L 94 x W 62 x H 31.5 mm (WS 4/70)
(weight: approx. 0.33 kg)

Part no.: **223104 0070**

Stainless steel: **223104 1070**

L 124 x W 62 x H 31.5 mm (WS 4)
(weight: approx. 0.46 kg)

Part no.: **223104**

Stainless steel: **223104 1000**

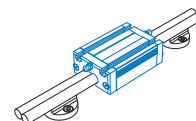

Steel slide LS 1

- clamping surface ground
- weight: approx. 0.8 kg

Part no.: **223006**

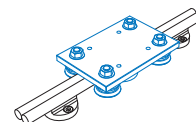

Trolley LW 3

- L 125 x W 85 x H 7.7 mm
 - ground steel plate
 - weight: approx. 0.9 kg
- Part no.: **223008**

Shaft housing blocks

- Ø 40 mm, hole spacing 28 mm
 - cast zinc, VE 10 units
- Part no.: **221501**

Load data

Shaft slide WS 4/70		Shaft slide WS 4		Steel slide LS 1		Trolley LW 8	
C ₀	3003 N	C ₀	4868 N	C ₀	3508 N	C ₀	2160 N
C	1873 N	C	2426 N	C	2105 N	C	4000 N
F ₁ static	2821 N	F ₁ static	4157 N	F ₁ static	3549 N	F ₁ static	4320 N
F ₁ dynamic	1599 N	F ₁ dynamic	2071 N	F ₁ dynamic	2130 N	F ₁ dynamic	3846 N
F ₂ static	3303 N	F ₂ static	4868 N	F ₂ static	3508 N	F ₂ static	2160 N
F ₂ dynamic	1873 N	F ₂ dynamic	2426 N	F ₂ dynamic	2105 N	F ₂ dynamic	4000 N
M _x static	29.8 Nm	M _x static	43.9 Nm	M _x static	36.2 Nm	M _x static	109.5 Nm
M _y static	105.3 Nm	M _y static	155.2 Nm	M _y static	129.0 Nm	M _y static	194.4 Nm
M _z static	123.3 Nm	M _z static	181.7 Nm	M _z static	127.5 Nm	M _z static	97.2 Nm
M _x dynamic	16.8 Nm	M _x dynamic	21.8 Nm	M _x dynamic	21.7 Nm	M _x dynamic	97.4 Nm
M _y dynamic	59.7 Nm	M _y dynamic	77.3 Nm	M _y dynamic	77.4 Nm	M _y dynamic	173.0 Nm
M _z dynamic	69.9 Nm	M _z dynamic	90.5 Nm	M _z dynamic	76.5 Nm	M _z dynamic	180.0 Nm

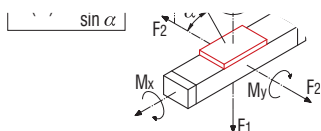

Linear guide rails

LFS-12-1

Dimensioned drawings

LFS-12-1 with trolley LW 3

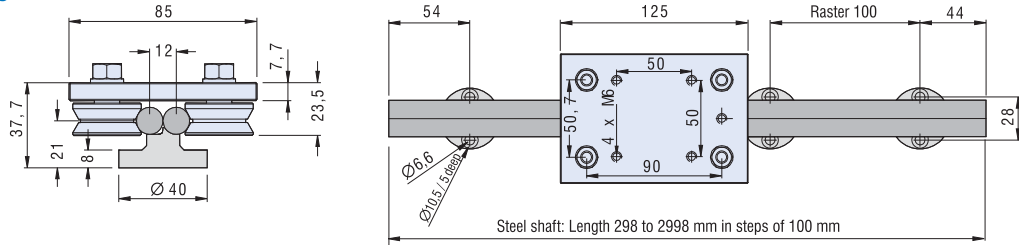

LFS-12-1 with Shaft slide WS 4/70 or WS 4

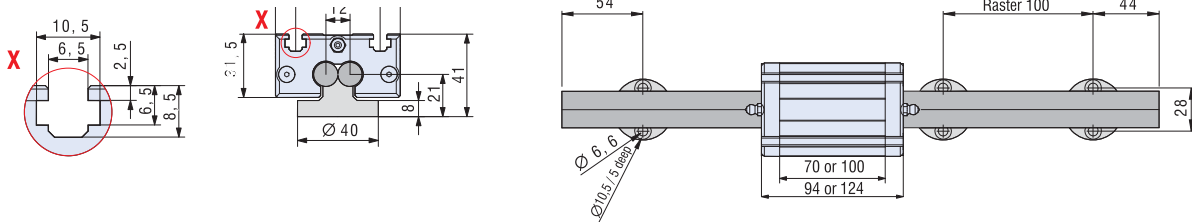

LFS-12-1 with steel slide LS 1

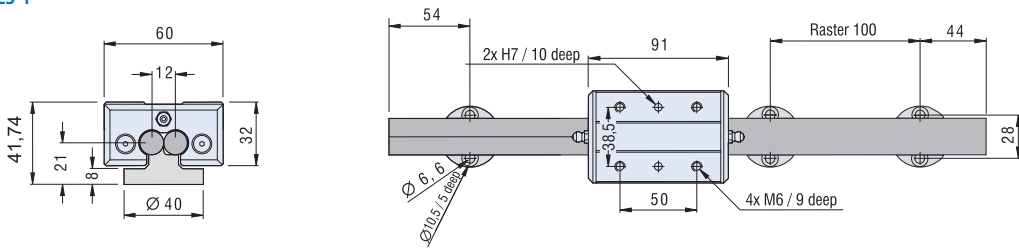

Shaft housing block

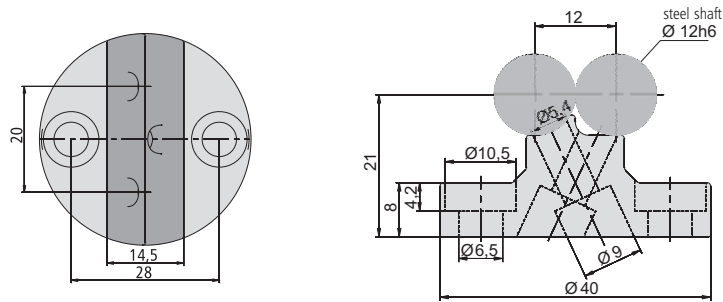

Linear guide rail

LFS-12-11



Features

- W 20 x H 31 mm
- Precision steel shaft Ø 12
- Aluminium shaft housing profile, naturally anodised
- Securing from below with M6 tapped rail in T-slot insert on flat surface
- Special lengths available on request
- Weight: approx. 1.3 kg/m

Ordering key

220 002 XXXX

Length in mm
 e.g. **0298** = Length 298
0998 = Length 998
 Profile length = Length overall L -2 mm

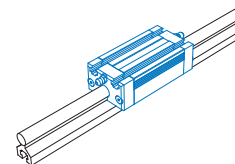

Aluminium slides

- With recirculating ball guide
- M6 T-slot inserts
- Central lubrication system option
- Adjustable for no play
- Option: stainless steel version

Load data

Shaft slides WS 6/70	
C ₀	3303 N
C	1873 N
F ₁ static	2821 N
F ₁ dynamic	1599 N
F ₂ static	3303 N
F ₂ dynamic	1873 N
M _x static	-
M _y static	105.3 Nm
M _z static	123.3 Nm
M _x dynamic	-
M _y dynamic	59.7 Nm
M _z dynamic	69.9 Nm

Shaft slides WS 6	
C ₀	4868 N
C	2426 N
F ₁ static	4157 N
F ₁ dynamic	2071 N
F ₂ static	4868 N
F ₂ dynamic	2426 N
M _x static	-
M _y static	155.2 Nm
M _z static	181.7 Nm
M _x dynamic	-
M _y dynamic	77.3 Nm
M _z dynamic	90.5 Nm

Trolley LW 5	
C ₀	2160 N
C	4000 N
F ₁ static	4320 N
F ₁ dynamic	3846 N
F ₂ static	2160 N
F ₂ dynamic	4000 N
M _x static	-
M _y static	162.0 Nm
M _z static	81.0 Nm
M _x dynamic	-
M _y dynamic	144.2 Nm
M _z dynamic	150.0 Nm

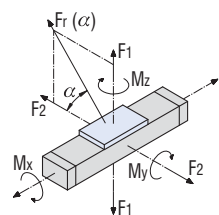

$$Fr(\alpha) = \frac{F_2}{\cos \alpha}$$

$$Fr(\alpha) = \frac{F_1}{\sin \alpha}$$

L 96 x W 50 x H 31.5 mm (WS 6/70)
 (weight: approx. 0.3 kg)

Part no.: **223106 0070**
 Stainless steel: **223106 1070**

L 126 x W 50 x H 31,5 mm (WS 6)
 (weight: approx. 0.5 kg)

Part no.: **223106**
 Stainless steel: **223106 1000**

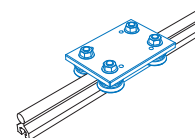

Trolley LW 5

- L 110 x W 75 x H 7.7 mm
- Ground steel plate
- 4 rollers Ø 31, sealed for life
- Adjustable for no play
- Weight: 0.81 kg

Part no.: **223010**

Linear guide rail

LFS-12-11

Bending

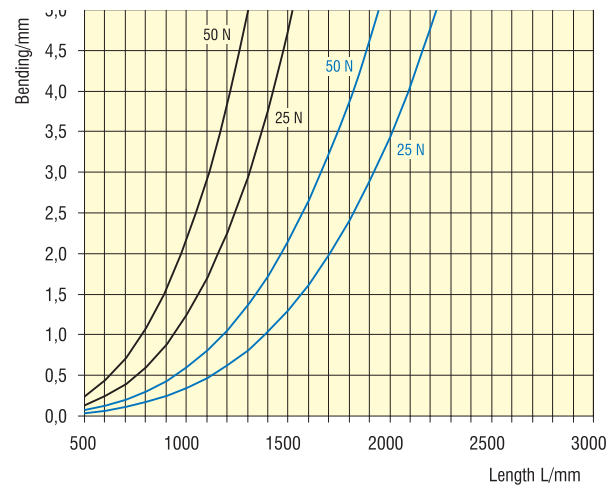
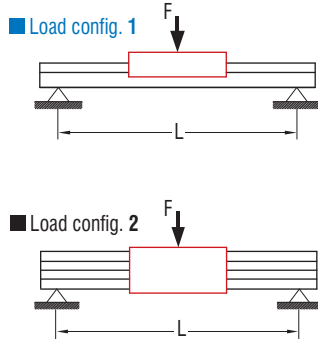

Dimensioned drawings

LFS-12-11 with aluminium slides WS 6/70 or WS 6

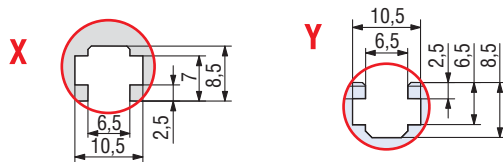
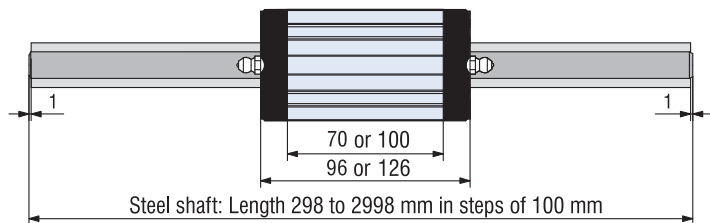
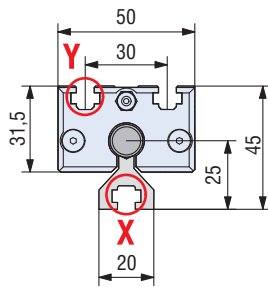

LFS-12-11 with trolley LW5

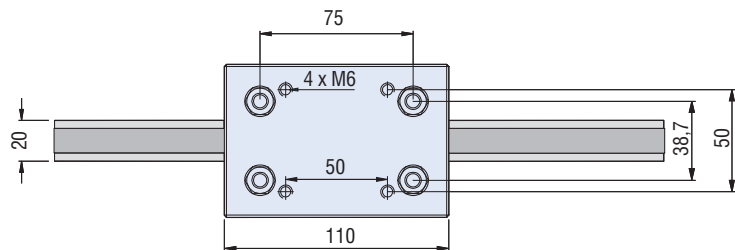
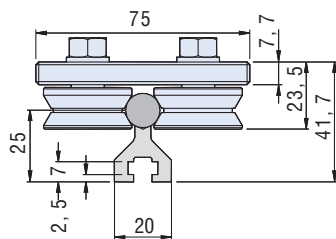

Linear guide rail

LFS-12-2



Features

- W 62 x H 31 mm
- 2 precision steel shafts Ø 12
- Anti-twist lock
- Aluminium shaft housing profile, naturally anodised
- High parallelism through patented shaft housing outline
- High guidance accuracy
- Securing from above or below using drilled holes Ø 6.5 in 100 mm raster on flat surface
- Lengths in 100 mm raster
- Max. length up to 2998 mm
- Special lengths to order
- Weight: approx. 3.3 kg/m

Ordering key

235 200 XXXX

Length in mm
 e.g. **0298** = Length 298
0998 = Length 998
 Profile length = Length overall L -2 mm

Aluminium slides

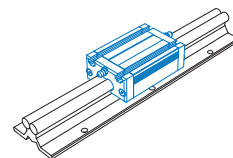

- With recirculating ball guide
- Clamping surface plane milled
- Adjustable for no play
- Option: stainless steel version

L 94 x W 62 x H 31.5 mm (WS 4/70)
 (weight: approx. 0.33 kg)

Part no.: **223104 0070**
 Stainless steel: **223104 1070**

L 124 x W 62 x H 31.5 mm (WS 4)
 (weight: approx. 0.46 kg)

Part no.: **223104**
 Stainless steel: **223104 1000**

Load data

Shaft slides WS 4/70	
C ₀	3003 N
C	1873 N
F ₁ static	2821 N
F ₁ dynamic	1599 N
F ₂ static	3303 N
F ₂ dynamic	1873 N
M _x static	29.8 Nm
M _y static	105.3 Nm
M _z static	123.3 Nm
M _x dynamic	16.8 Nm
M _y dynamic	59.7 Nm
M _z dynamic	69.9 Nm

Shaft slides WS 4	
C ₀	4868 N
C	2426 N
F ₁ static	4157 N
F ₁ dynamic	2071 N
F ₂ static	4868 N
F ₂ dynamic	2426 N
M _x static	43.9 Nm
M _y static	155.2 Nm
M _z static	181.7 Nm
M _x dynamic	21.8 Nm
M _y dynamic	77.3 Nm
M _z dynamic	90.5 Nm

Trolley LW 3	
C ₀	2160 N
C	4000 N
F ₁ static	4320 N
F ₁ dynamic	3846 N
F ₂ static	2160 N
F ₂ dynamic	4000 N
M _x static	109.5 Nm
M _y static	194.4 Nm
M _z static	97.2 Nm
M _x dynamic	97.4 Nm
M _y dynamic	173.0 Nm
M _z dynamic	180.0 Nm

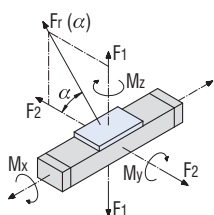

$$Fr(\alpha) = \frac{F_2}{\cos \alpha}$$

$$Fr(\alpha) = \frac{F_1}{\sin \alpha}$$

Steel slide LS 1

- L 91 x W 60 x H 32 mm
- clamping surface ground
- weight: approx. 0.8 kg

Part no.: **223006**

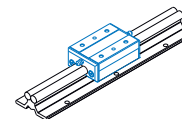

Trolley LW 3

- L 125 x W 85 x H 7.7 mm
- Ground steel plate
- Weight: 0.93 kg

Part no.: **223008**

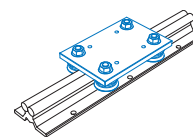

Linear guide rail

LFS-12-2

Bending

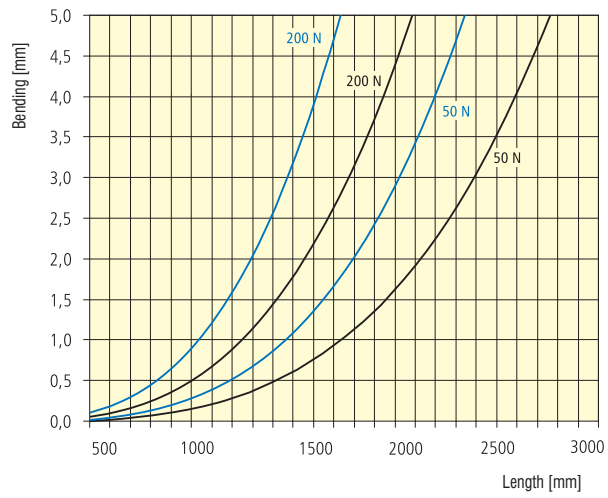
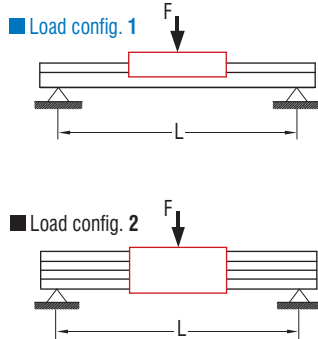

Dimensioned drawings

LFS-12-2 with aluminium slides WS 4/70 or WS 4

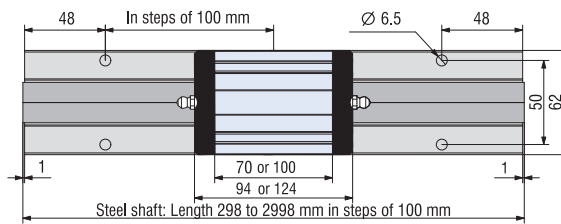
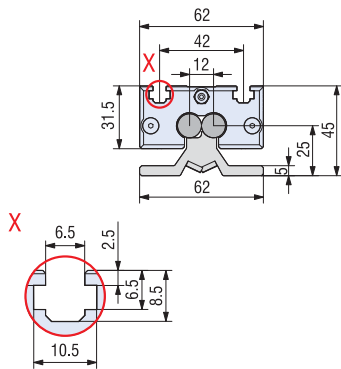

LFS-12-2 with trolley LW3

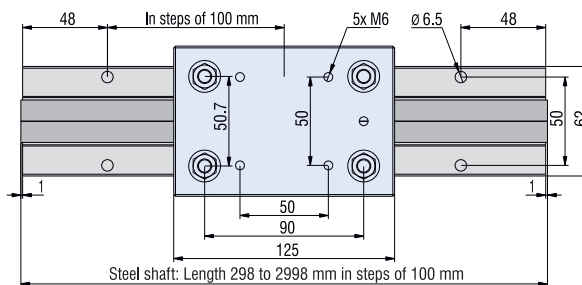
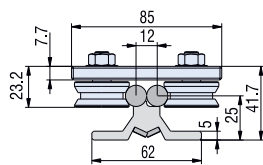

LFS-12-2 with steel slide LS 1

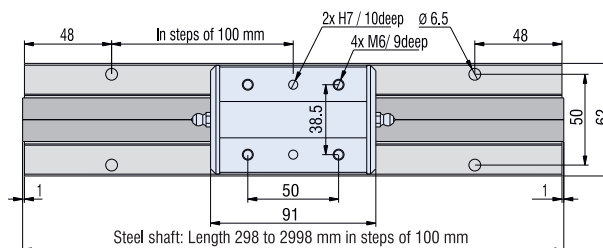
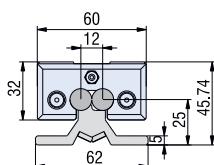

Linear guide rail

LFS-12-3

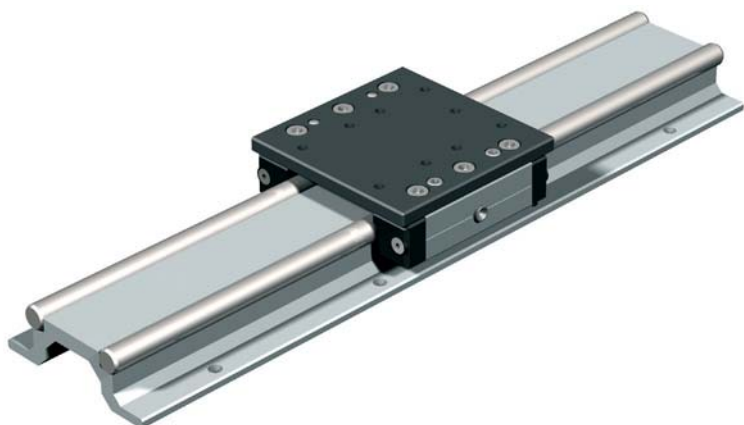

Features

- W 90 x H 31 mm
- 2 precision steel shafts Ø 12
- Anti-twist
- Aluminium shaft housing profile, naturally anodised
- increased shaft spacing allows higher torques to be absorbed
- Securing from above or below with M6 drillings in 100 mm raster
- Any guide length
- Weight: approx. 3.9 kg/m

Ordering key

235 300 XXXX

Length in mm (in 100 mm raster)
e.g. **0029** = Length 298
0299 = Length 2998

Profile length = Length overall L - 2 mm

Special lengths over 3000 mm with rod linkage to order.

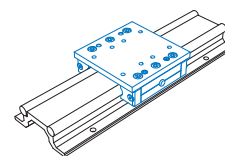

Slides

- Ground steel plate
- Central lubrication system option
- Adjustable for no play

L 100 x W 100 x H 32 mm (WS 7/70)
(weight: approx. 0.8 kg)
Part no.: **223107 0070**

L 200 x W 100 x H 32 mm (WS 7)
(weight: approx. 1.7 kg)
Part no.: **223107**

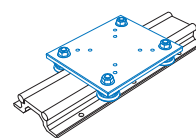

Trolley LW 8

- L 150 x W 125 x H 7.5 mm
- Ground steel plate
- 4 rollers Ø 31, sealed for life
- Adjustable for no play
- Weight: 1.51 kg

Part no.: **223013**

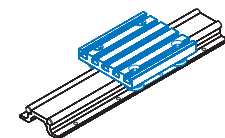

Trolley LW 2

- L 150 x W 125 x H 34.5 mm
- Aluminium T-slot plate
- 4 rollers Ø 31, sealed for life
- Adjustable for no play
- Weight: 0.97 kg

Part no.: **223005**

Load data

Shaft slides WS 7/70		Shaft slides WS 7		Trolley LW 2		Trolley LW 8	
C ₀	3303 N	C ₀	7303 N	C ₀	3114 N	C ₀	2160 N
C	1873 N	C	3179 N	C	1846 N	C	4000 N
F ₁ static	2821 N	F ₁ static	6237 N	F ₁ static	2659 N	F ₁ static	4320 N
F ₁ dynamic	1599 N	F ₁ dynamic	2715 N	F ₁ dynamic	1576 N	F ₁ dynamic	3846 N
F ₂ static	3303 N	F ₂ static	7303 N	F ₂ static	3114 N	F ₂ static	2160 N
F ₂ dynamic	1873 N	F ₂ dynamic	3179 N	F ₂ dynamic	1846 N	F ₂ dynamic	4000 N
M _x static	82.0 Nm	M _x static	181.2 Nm	M _x static	216.0 Nm	M _x static	189.2 Nm
M _y static	105.3 Nm	M _y static	232.8 Nm	M _y static	100.5 Nm	M _y static	248.4 Nm
M _z static	123.3 Nm	M _z static	272.5 Nm	M _z static	108.0 Nm	M _z static	124.2 Nm
M _x dynamic	46.4 Nm	M _x dynamic	78.8 Nm	M _x dynamic	168.4 Nm	M _x dynamic	168.4 Nm
M _y dynamic	59.7 Nm	M _y dynamic	101.3 Nm	M _y dynamic	192.3 Nm	M _y dynamic	221.1 Nm
M _z dynamic	69.9 Nm	M _z dynamic	118.6 Nm	M _z dynamic	200.0 Nm	M _z dynamic	230.0 Nm

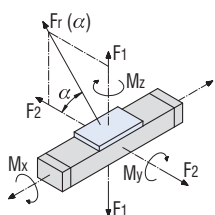

$$Fr(\alpha) = \frac{F_2}{\cos \alpha}$$

$$Fr(\alpha) = \frac{F_1}{\sin \alpha}$$

Linear guide rail

LFS-12-3

Bending

■ Load config. 1

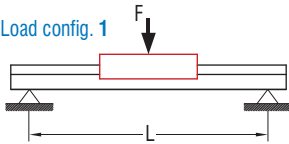

■ Load config. 2

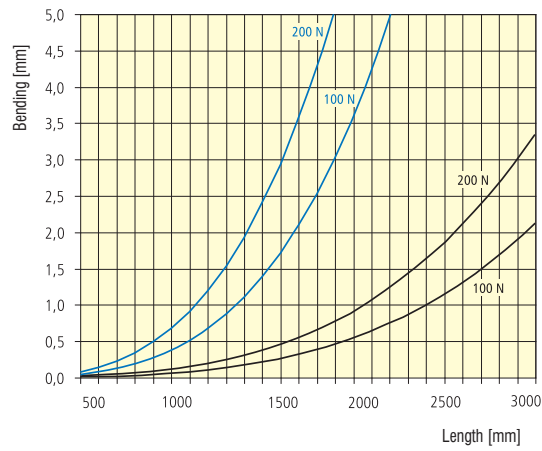
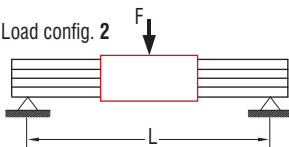

Dimensioned drawings

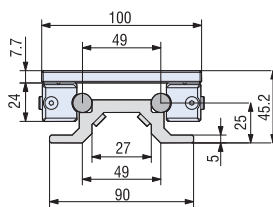

LFS-12-3 with aluminium slides WS 7

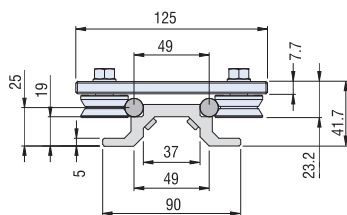
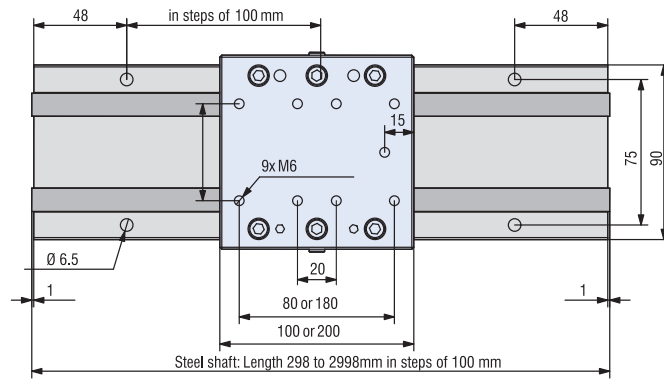

LFS-12-3 with trolley LW 8

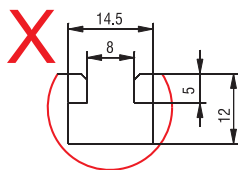
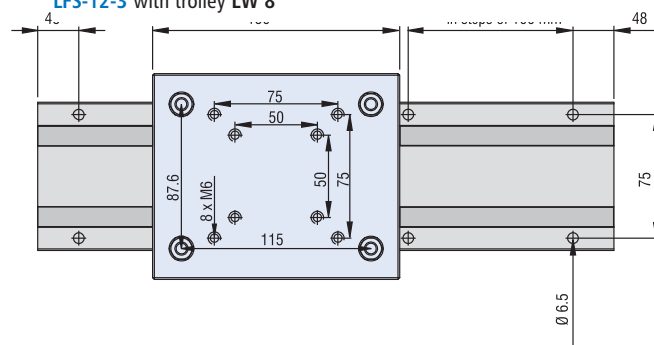

LFS-12-3 with trolley LW 2

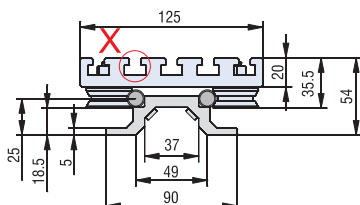
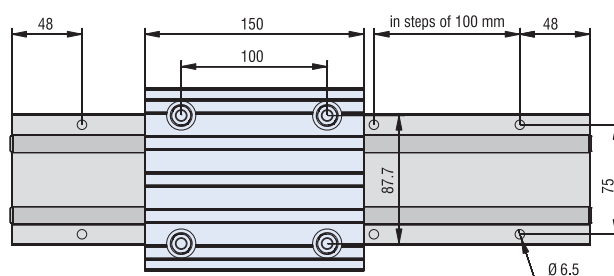

Linear guide rail

LFS-12-10

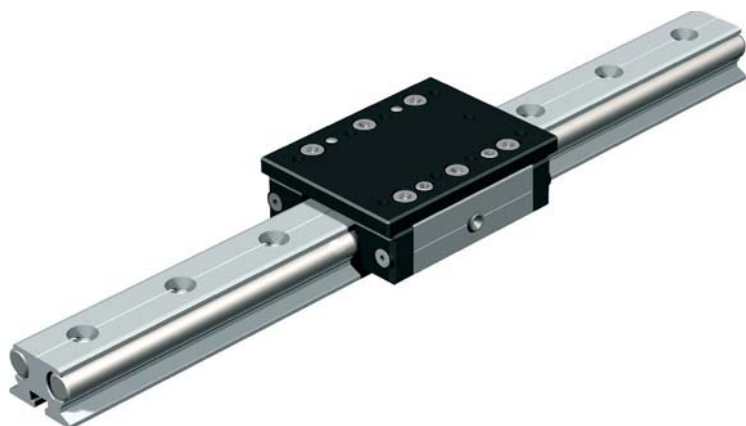

Features

- W 36 x H 24.5 mm
- 2 precision steel shafts Ø 12
- Anti-twist
- Aluminium shaft housing profile, naturally anodised
- Fixing from below with M6 tapped rail in T-slot insert and from above M6 drillings in the Raster 50 mm
- Conditionally self-supporting
- Special lengths to order
- Weight: approx. 2.9 kg/m

Ordering key

220 001 XXXX

Length in mm (in 100 mm raster)
e.g. **0300** = Length 296
3000 = Length 2996

Profile length = Length overall L - 1 mm

Special lengths over 3000 mm with rod linkage to order.

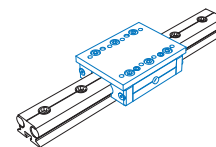

Slides

- Ground steel plate
- Lubrication system option
- Adjustable for no play

L 100 x W 75 x H 31.5 mm (WS 8/70)
(weight: approx. 0.7 kg)
Part no.: **223108 0070**

L 150 x W 75 x H 31.5 mm (WS 8)
(weight: approx. 1,0 kg)
Part no.: **223108**

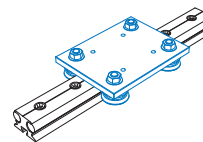

Trolley LW 4

- L 125 x W 97 x H 7.7 mm
- Ground steel plate
- 4 rollers Ø 31, sealed for life
- Adjustable for no play
- Weight: 1.02 kg

Part no.: **223009**

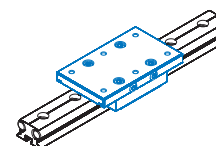

For steel shafts Ø 12 mm

Dual track set 1

- L75 x W75 x H30.2 mm
- With 2 SMALL linear ball bearings

Part no.: **223001**

Dual track set 2

- L125 x W75 x H30.2 mm
- With 2 LARGE linear ball bearings

Part no.: **223002**

Load data

Slides WS 8/70		Slides WS 8		Trolley LW 4				Dual track set 1		Dual track set 2	
C ₀	3303 N	C ₀	4868 N	C ₀	2160 N	C ₀	645 N	645 N	1905 N		
C	1873 N	C	2426 N	C	4000 N	C	600 N	600 N	1125 N		
F ₁ static	2821 N	F ₁ static	4157 N	F ₁ static	4320 N	F ₁ static	652 N	652 N	1927 N		
F ₁ dynamic	1599 N	F ₁ dynamic	2071 N	F ₁ dynamic	3846 N	F ₁ dynamic	607 N	607 N	1138 N		
F ₂ static	3303 N	F ₂ static	4868 N	F ₂ static	2160 N	F ₂ static	645 N	645 N	1905 N		
F ₂ dynamic	1873 N	F ₂ dynamic	2426 N	F ₂ dynamic	4000 N	F ₂ dynamic	600 N	600 N	1125 N		
M _x static	46.7 Nm	M _x static	68.8 Nm	M _x static	135.4 Nm	M _x static	16.0 Nm	16.0 Nm	46.0 Nm		
M _y static	105.3 Nm	M _y static	155.2 Nm	M _y static	194.4 Nm	M _y static	13.0 Nm	13.0 Nm	119 Nm		
M _z static	123.3 Nm	M _z static	181.7 Nm	M _z static	97.2 Nm	M _z static	13.0 Nm	13.0 Nm	118 Nm		
M _x dynamic	26.4 Nm	M _x dynamic	34.2 Nm	M _x dynamic	120.5 Nm	M _x dynamic	15.0 Nm	15.0 Nm	27.0 Nm		
M _y dynamic	59.7 Nm	M _y dynamic	77.3 Nm	M _y dynamic	173.0 Nm	M _y dynamic	12.0 Nm	12.0 Nm	71.0 Nm		
M _z dynamic	69.9 Nm	M _z dynamic	90.5 Nm	M _z dynamic	180.0 Nm	M _z dynamic	12.0 Nm	12.0 Nm	70.0 Nm		

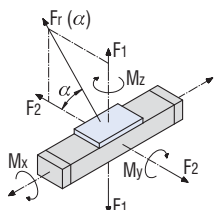

$$Fr(\alpha) = \frac{F_2}{\cos \alpha}$$

$$Fr(\alpha) = \frac{F_1}{\sin \alpha}$$

Linear guide rail

LFS-12-10

Bending

■ Load config. 1

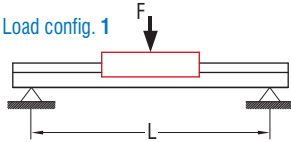

■ Load config. 2

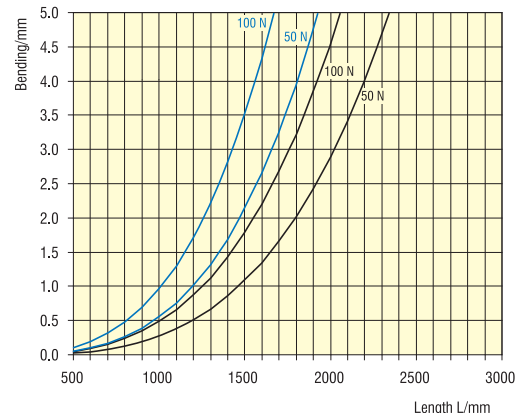
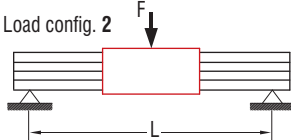

Dimensioned drawings

LFS-12-10 with slides WS 8

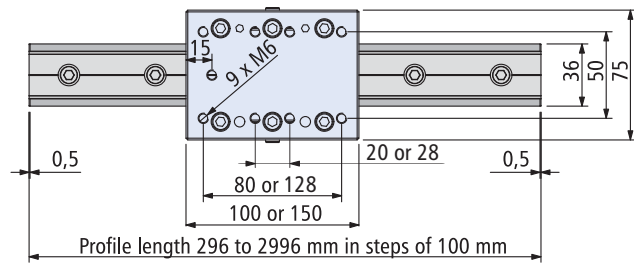
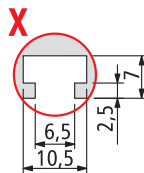
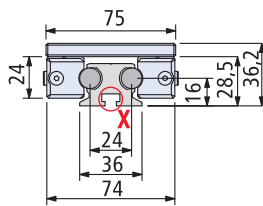

LFS-12-10 with trolley LW 4

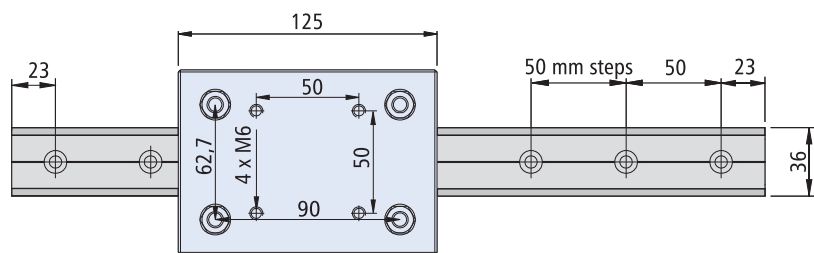
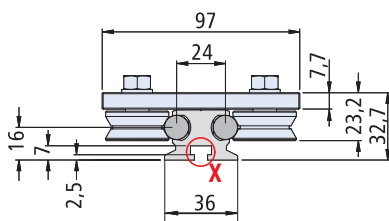

LFS-12-10 with dual track set

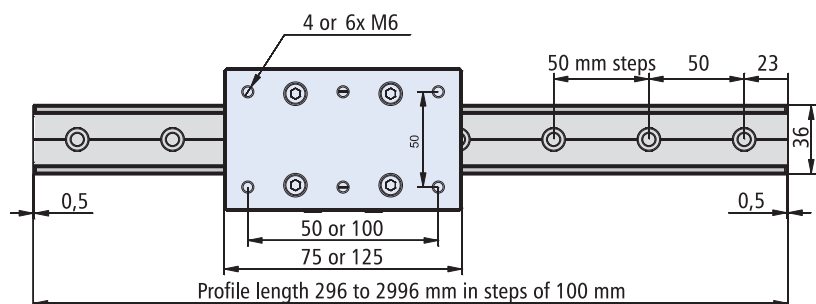
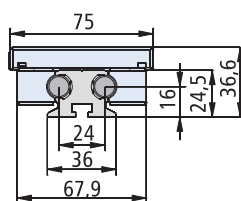

Linear guide rail

LFS-16-120



Features

- W 190 x H 61 mm
- 2 precision steel shafts Ø 16
- Anti-twist
- Aluminium shaft housing profile naturally anodised
- Securing from below with M6 tapped rail in T-slot profile
- Conditionally self-supporting
- Any guide length
- Weight: 10.2 kg/m

Ordering key

220 008 XXXX

Length in mm (in 100 mm raster)

e.g. **0029** = Length 298

0299 = Length 2998

Profile length = Length overall L - 2 mm

Special lengths available on request!

Load data

$$F_r(\alpha) = \frac{F_2}{\cos \alpha}$$

$$F_r(\alpha) = \frac{F_1}{\sin \alpha}$$

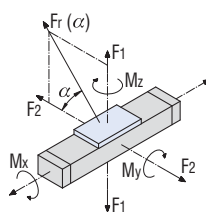

Unit with 2 x IWS 1	Unit with 2 x ILS 1	Unit with 4 x IWS 1	Unit with 4 x ILS 1
C ₀ 4929 N	C ₀ 7598 N	C ₀ 6572 N	C ₀ 10130 N
C 2660 N	C 4857 N	C 3546 N	C 6476 N
F ₁ stat. 4209 N	F ₁ stat. 6488 N	F ₁ stat. 5612 N	F ₁ stat. 8650 N
F ₁ dyn. 2271 N	F ₁ dyn. 4148 N	F ₁ dyn. 3028 N	F ₁ dyn. 5530 N
F ₂ stat. 4929 N	F ₂ stat. 7598 N	F ₂ stat. 6572 N	F ₂ stat. 10130 N
F ₂ dyn. 2660 N	F ₂ dyn. 4857 N	F ₂ dyn. 3546 N	F ₂ dyn. 6476 N
M ₂ stat. 253 Nm	M ₂ stat. 389 Nm	M ₂ stat. 337 Nm	M ₂ stat. 519 Nm
M ₂ stat. 147 Nm	M ₂ stat. 195 Nm	M ₂ stat. 309 Nm	M ₂ stat. 476 Nm
M ₂ stat. 173 Nm	M ₂ stat. 228 Nm	M ₂ stat. 361 Nm	M ₂ stat. 557 Nm
M ₂ dyn. 136 Nm	M ₂ dyn. 249 Nm	M ₂ dyn. 182 Nm	M ₂ dyn. 332 Nm
M ₂ dyn. 79 Nm	M ₂ dyn. 124 Nm	M ₂ dyn. 167 Nm	M ₂ dyn. 304 Nm
M ₂ dyn. 93 Nm	M ₂ dyn. 146 Nm	M ₂ dyn. 195 Nm	M ₂ dyn. 356 Nm

Bending

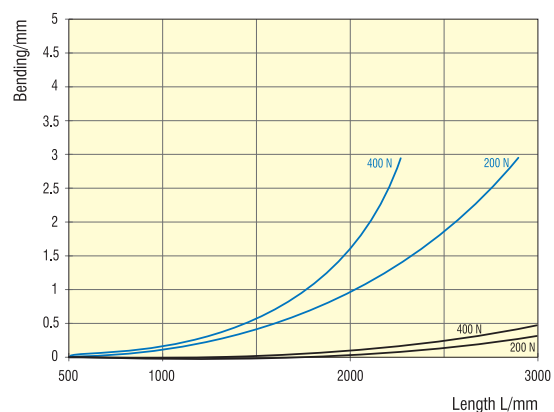
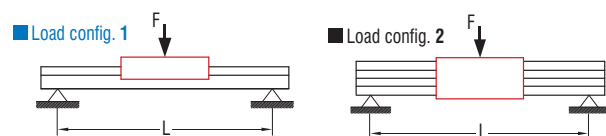

Linear guide rail

LFS-16-120

Slide unit with 2 × steel slides ILS 1 (kit)

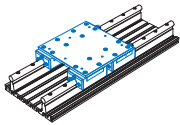

- L 84 x W 178 x H 8 mm
- Ground steel plate
- 2 x ILS 1, central lubrication option
- Adjustable for no play
- Total weight: 2.30 kg

Part no.: **223240 0009**

Slide unit with 2 × aluminium slides IWS 1 (kit)

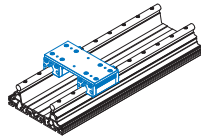

- L 84 x W 178 x H 8 mm
- Ground steel plate
- 2 × IWS 1, central lubrication option
- Adjustable for no play
- Total weight: 1.50 kg

Part no.: **223240 0007**

Slide unit with 4 × aluminium slides IWS 1 (kit)

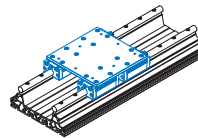

- L 180 x W 178 x H 8 mm
- Ground steel plate
- 4 x IWS 1, central lubrication option
- Adjustable for no play

Part no.: **223240 0008**

Slide unit with 4 × steel slides ILS 1 (kit)

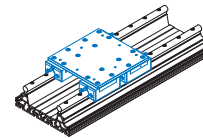

- L 180 x W 178 x H 8 mm
- ground steel plate
- 4 x ILS 1, central lubrication option
- Adjustable for no play

Part no.: **223240 0010**

Dimensioned drawings

Aluminium slides IWS 1

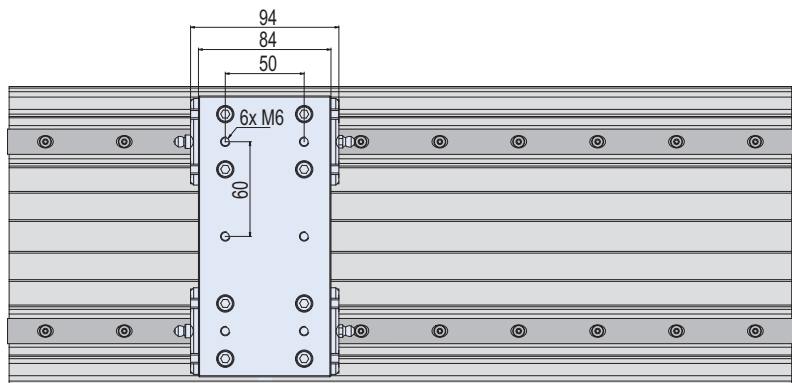
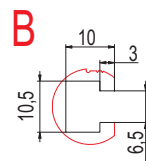
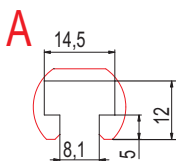
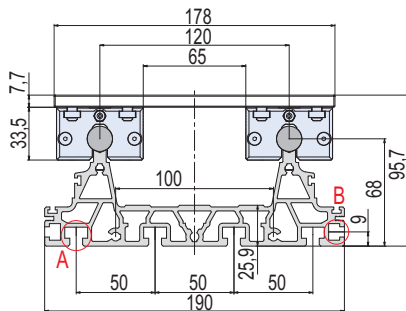

Steel slides ILS 1

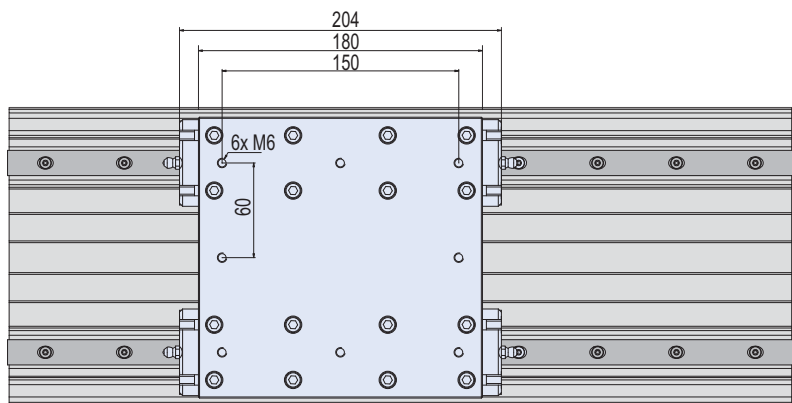
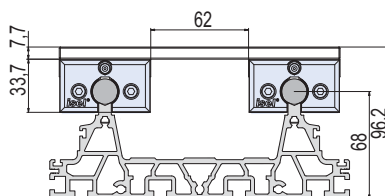

Linear guides

LSK

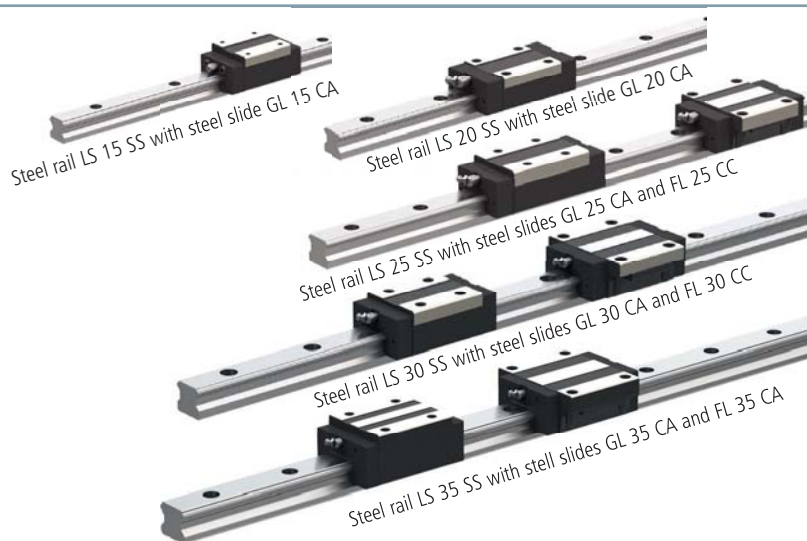

Features

- Precision steel rails and slides, in size 15, 20, 25, 30 and 35
- four-row roller bearings with wiper, in different slide sizes
- hardened and grounded
- smooth running characteristics and low wear
- High accuracy and parallelism of the rails and slides
- High precision, high rigidity and high efficiency
- Standard length up to 4000 mm, special length on request
- Products interconvertible

General

The LSK linear guides allows linear motion with the help of balls. Through the use of balls between the rail and the slide, the LSK linear guides can achieve an extremely precise linear motion. Compared with a conventional slide, the coefficient of friction makes up only of one-fiftieth. Because of the forced guidance of the slide on the rail, they can accommodate vertical and horizontal direction loads.

Ordering key

Precision steel rail

223 5XX XXXX



Sizes

15 ... LS 15 SS
20 ... LS 20 SS
25 ... LS 25 SS

Length in mm

(in a grid of 120 mm)
e.g.: **0178** = 178 mm
0298 = 298 mm
1978 = 1978 mm*
2998 = 2998 mm**
3898 = 3898 mm***

* maximal length for LS 15 SS
** maximal length for LS 20 SS
*** maximal length for LS 25 SS

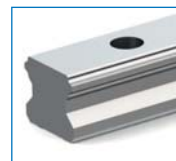

223 5XX XXXX

Sizes

30 ... LS 30 SS
35 ... LS 35 SS

Length in mm

(in a grid of 160 mm)
e.g.: **0238** = 238 mm
0398 = 398 mm
1998 = 1998 mm
2958 = 2958 mm
3998 = 3998 mm

Slides

223 500 XX00



Version

01 ... FL 15 CC **09** ... GL 15 CA
02 ... FL 20 CC **10** ... GL 20 CA
04 ... FL 25 CC **12** ... GL 25 CA
06 ... FL 30 CC **14** ... GL 30 CA
08 ... FL 35 CC **17** ... GL 35 CA

Load data

Flange model					
	FL 15 CC	FL 20 CC	FL 25 CC	FL 30 CC	FL 35 CC
C ₀	13,533 N	23,830 N	34,421 N	46,777 N	61,095 N
C	8,335 N	13,827 N	19,907 N	28,047 N	37,265 N
M _A	71 Nm	155 Nm	269 Nm	429 Nm	641 Nm
M _B	71 Nm	155 Nm	269 Nm	429 Nm	641 Nm
M _C	99 Nm	232 Nm	392 Nm	645 Nm	1,026 Nm
Weight	0.2 kg	0.35 kg	0.59 kg	1.1 kg	1.6 kg

Block model					
	GL 15 CA	GL 20 CA	GL 25 CA	GL 30 CA	GL 35 CA
C ₀	13,533 N	23,830 N	34,421 N	46,777 N	61,095 N
C	8,335 N	13,827 N	19,907 N	28,047 N	37,265 N
M _A	71 Nm	155 Nm	269 Nm	429 Nm	641 Nm
M _B	71 Nm	155 Nm	269 Nm	429 Nm	641 Nm
M _C	99 Nm	232 Nm	392 Nm	645 Nm	1,026 Nm
Weight	0.18 kg	0.25 kg	0.54 kg	0.9 kg	1.6 kg

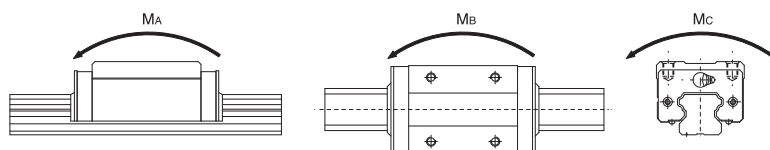

Linear guides

LSK

Dimensioned drawings

Flange model FL

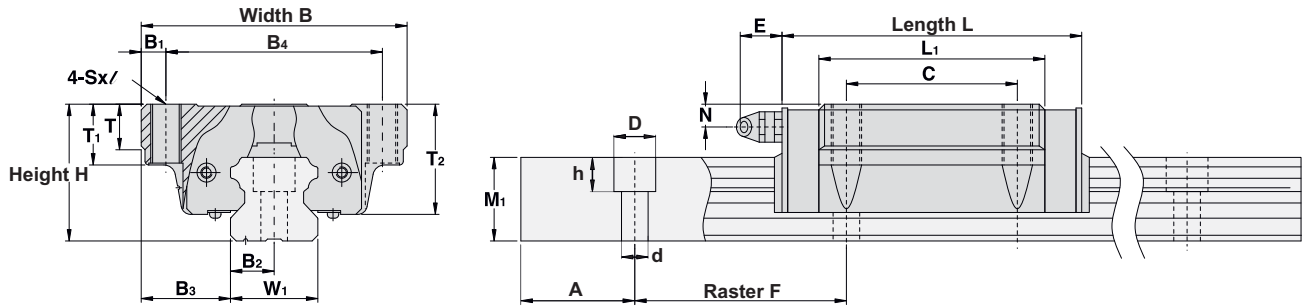

model	B	B1	B2	B3	B4	L	L1	C	T	T1	T2	Sx/	N	E	W1	M1	A	Raster F	d x D x h
FL 15 CC	47	4.5	7.5	16	38	56.2	38.2	30	7	11	19.5	M5 x 7	4.5	7	15	15	29	60	4.7 x 7.5 x 5.5
FL 20 CC	63	5	10	21.5	53	76.5	50.5	40	9.5	10	24.5	M6 x 9.5	5	12	20	18	29	60	6 x 9.5 x 8.5
FL 25 CC	70	6.5	11.5	23.5	57	84	58	45	12	16	29	M8 x 12	6	12	23	22	29	60	7 x 11 x 9
FL 30 CC	90	9	14	31	72	100.5	70.5	52	12	18	34	M10 x 12	7	12	28	26	39	80	9 x 14 x 12
FL 35 CA	100	9	17	33	82	105.5	80.5	62	13	21	39	M 10 x 21	8	12	34	29	39	80	9 x 14 x 12

Block model GL

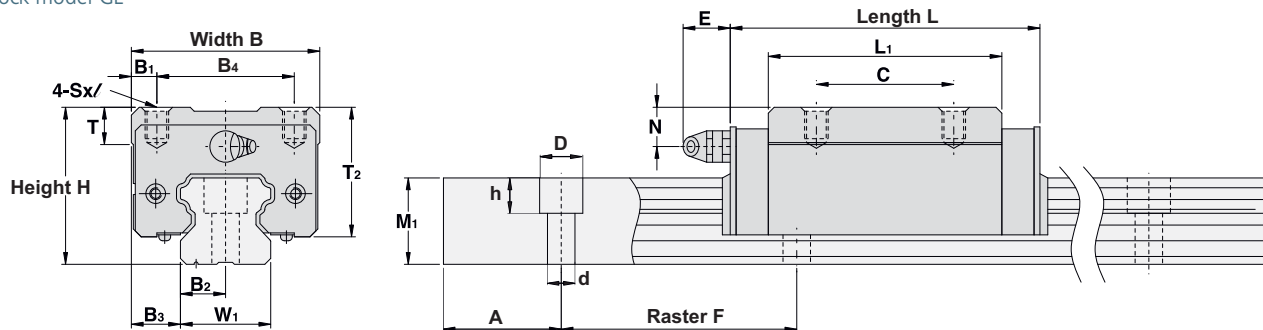

model	B	B1	B2	B3	B4	L	L1	C	T	T2	Sx/	N	E	W1	M1	A	Raster F	d x D x h
GL 15 CA	34	4	7.5	9.5	26	56.2	38.2	26	6	23.5	M4 x 5	8.5	7	15	15	29	60	4.7 x 7.5 x 5.5
GL 20 CA	44	6	10	12	32	76.5	50.5	36	8	24.5	M5 x 6	5	12	20	18	29	60	6 x 9.5 x 8.5
GL 25 CA	48	6.5	11.5	12.5	35	84	58	35	12	33	M6 x 8	10	12	23	22	29	60	7 x 11 x 9
GL 30 CA	60	10	14	16	40	100.5	70.5	40	12	37	M8 x 10	10	12	28	26	39	80	9 x 14 x 12
GL 35 CA	70	10	17	33	50	105.5	80.5	50	12	46	M8 x 12	15	12	34	29	39	80	9 x 14 x 12

Accessories

Tapped rail

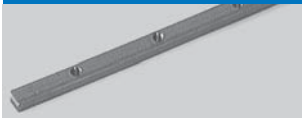

M6 tapped rail

- 10 x 4 mm
- Galvanised
- M6 Ra 50 mm
- VE 3 units at 1 m

Part no.: **209 011**

Sliding nuts



M6 sliding nut (Figure 1)

- L 25 x W 10 x H 3.5 mm
- Galvanised
- VE 100 unit
- All except PT/RE 40, 65

Part no.: **209 001 0005**

2 x M6 sliding nuts (Figure 2)

- L 45 x W 10 x H 3.5
- Galvanised
- VE 50 unit
- For all except PT/RE 40, 65

Part no.: **209 002 0004**

2 x M6 sliding nuts (Figure 2)

- L 45 x W 13 x H 6 mm
- Galvanised
- 2 x M6 Ra 25 mm
- VE 25 unit
- For PT/RE 40, 65

Part no.: **209 005 0001**

Angle sliding nut

2 x M6 (Figure 3)

- Galvanised
- VE 25 units
- For all except PT/RE 40, 65

Part no.: **209 021 0003**

Special angle sliding nut

3 x M6 (Figure 4)

- Galvanised, VE 25 unit
- For all except PT/RE 40, 65

Part no.: **209 022 0003**

Sliding nuts



M5 sliding nuts

- Galvanised • VE 20 unit
 - For all except PT25, PT 50, PS 200, RE 40 and RE 65
- (Securing only possible from above)

with spring

Part no.: **209005 0002**

(M5/Figure 1)

Part no.: **209005 0003**

(M6/Figure 2)

with large chamfer

Part no.: **209005 0004**

(M6/Figure 3)

in rhombus shape

Part no.: **209005 0005**

(M5/Figure 4)

Part no.: **209005 0006**

(M6/Figure 5)

Linear ball bearing



For steel shafts \varnothing 12 mm

Linear ball bearing large

- L80 x W20 x H19 mm, VE 2 units

Part no.: **222 002 0001**

Linear ball bearing medium

- L60 x W20.5 x H17.8 mm, VE2 units

Part no.: **222 000**

Linear ball bearing small

- L40 x W20 x H19 mm, VE 2 units

Part no.: **222 001**

Grease/grease gun

Grease

Part no.: **299 031**

Impact press for grease and oil

Part no.: **931 170**

Guide shafts



Guide shaft SF 12/SF 16

- Precision steel shafts
- \varnothing 12 or 16 mm, length 3 m
- Hardened and ground
- With M5 blind hole tapping (SF12) or M6 (SF16) in 100 mm raster or with drilled holes for M4 (SF 12) or M5 (SF 16) in 100 mm raster

Part no.: **220019 0299**

(SF12, 3m, with blind holes for M5)

Part no.: **220020 0299**

(SF12, 3m, with stepped holes for M4)

Part no.: **220023 0299**

(SF16, 3m, with stepped holes for M5)

Part no.: **220024 0299**

(SF16, 3m, with blind holes for M6)

Rollers



Roller \varnothing 20 mm for SF 12

- With M4 tapped drilling
- VE 2 units

Part no.: **222 010**

Rollers



Roller \varnothing 21 mm

- Concentric
- VE 2 units

Part no.: **222 003**

- Eccentric
- VE 2 units

Part no.: **222 004**

Roller \varnothing 31 mm

- Concentric
- VE 2 units

Part no.: **222 006**

- Eccentric
- VE 2 units

Part no.: **222 007**

Operating loads calculation

Effective loading calculation

Various factors affect the calculation of the loading of isel guides. This includes the position of the C of G of the load, tensile and compressive forces, torques, load and acceleration forces.

For a linear bench on 4 bearings, the bearing forces are calculated according to the force application point for various load directions.

The dimension LL/2 is used as the dimension L (see dimensioned drawings for the relevant guides).

The calculation can also be applied to a slide configuration with 2 slides.

The load factor in this case is CO/2.

Combined load

If the load alignment of an element does not coincide with one of the main load directions, then the equivalent load is calculated:

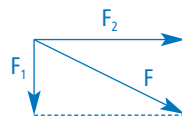

$$P = |F_1| + |F_2|$$

If a force F and a torque M load an element simultaneously, then the dynamically equivalent load is:

$$P = |F| + |M| \cdot \frac{C_0}{M_{0(XYZ)}}$$

- P [N] dynamically equivalent load
- F [N] opposing force $= \sqrt{F_1^2 + F_2^2}$
- F1 [N] vertical component see sketch (4)
- F2 [N] horizontal component see sketch (4)
- CO [N] static load factor
- M [Nm] opposing torque
- M0(XYZ) [Nm] static torque in the direction of the opposing torque

According to DIN, the dynamically equivalent load should not exceed the value $P = 0.5 \cdot C$.

Equivalent load calculation

Operating conditions

Equivalent load

A incremental change B uniform change

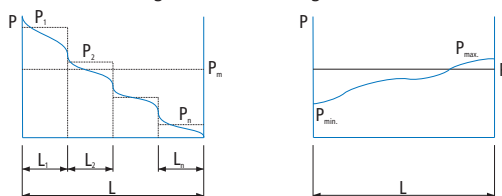

$$P = \sqrt[3]{\frac{1}{L} \cdot (P_1^3 \cdot L_1 + P_2^3 \cdot L_2 + P_3^3 \cdot L_3 + \dots + P_n^3 \cdot L_n)}$$

$$P = \frac{1}{3} \cdot (P_{\min} + 2 \cdot P_{\max})$$

- P dynamically equivalent load [N]
- P_{1...n} Individual load [N]
- L Total travel [m]
- L_{1...n} Individual travel [m]
- P_{min} smallest load [N]
- P_{max} largest load [N]

Static safety

Operating conditions	S_0
Normal motion	1.0 - 3.0
High speed	2.0 - 4.0
With impacts and vibration	3.0 - 5.0

$$S_0 = \frac{C_0}{P_0} = \frac{M_0}{M}$$

- S_0 static load safety
- C_0 static load factor [N]
- P_0 statically equivalent bearing loading [N]
- M_0 static loading torque [Nm]
- M equivalent static torque [Nm]

Nominal working life

The nominal working life is achieved or exceeded by 90% of an adequately large quantity of identical bearings, before the first signs of material fatigue become apparent.

$$L = \left(\frac{C}{P}\right)^3$$

$$L_h = \frac{833}{H \cdot n_{osz}} \cdot \left(\frac{C}{P}\right)^3$$

$$L_h = \frac{1666}{V} \cdot \left(\frac{C}{P}\right)^3$$

- L [m] nominal working life in units of 100,000 m
- L_h [h] nominal working life in hours run
- C [N] dynamic load factor
- P [N] dynamically equivalent load
- H [m] single stroke of the oscillating motion
- n_{osz} [min] Number of double strokes per minute
- v [m/min] average speed of movement

Operating loads calculation

Load vertical on the bench surface

Loading

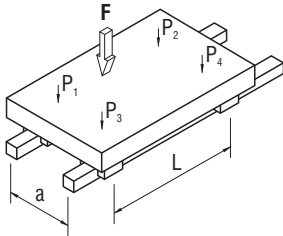

Dimensioned figure

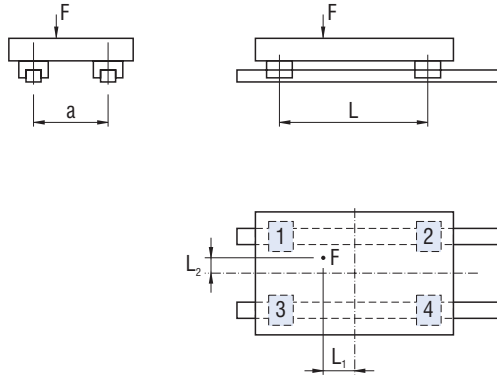

Load on a trolley

$$P_1 = \frac{F}{4} + \frac{F \cdot L_1}{2L} + \frac{F \cdot L_2}{2a}$$

$$P_2 = \frac{F}{4} - \frac{F \cdot L_1}{2L} + \frac{F \cdot L_2}{2a}$$

$$P_3 = \frac{F}{4} + \frac{F \cdot L_1}{2L} - \frac{F \cdot L_2}{2a}$$

$$P_4 = \frac{F}{4} - \frac{F \cdot L_1}{2L} - \frac{F \cdot L_2}{2a}$$

Load in direction of motion

Loading

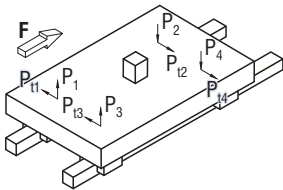

Dimensioned figure

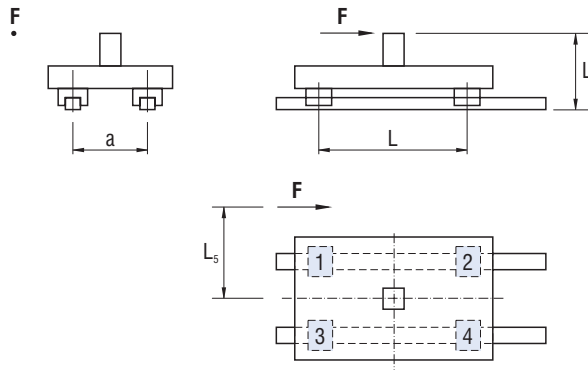

Load on a trolley

$$P_{1...P_4} = \frac{F \cdot L_6}{2L}$$

$$P_{11...P_{14}} = \frac{F \cdot L_5}{2L}$$

Load at right angles to the direction of motion

Loading

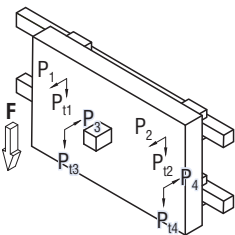

Dimensioned figure

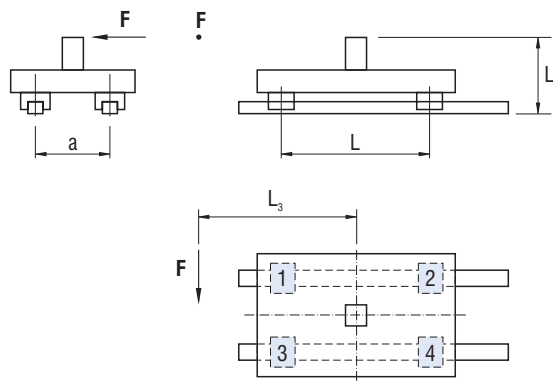

Load on a trolley

$$P_{1...P_4} = \frac{F \cdot L_4}{2a}$$

$$P_{11} = P_{13} = \frac{F}{4} + \frac{F \cdot L_3}{2L}$$

$$P_{12} = P_{14} = \frac{F}{4} - \frac{F \cdot L_3}{2L}$$

Space for your notes

Functional overview	B-32
Ball screw spindles \varnothing 12 - 25 mm	B-34
Plastic nuts	B-35
Ball screw nut with single-path return	B-36
Clamping blocks for nuts with single-path return	B-37
Ball screw nut with complete ball return	B-38
Flange bearings	B-39
Bearing supports	B-40
Couplings	B-41

Information

Ball screw nuts supplied by isel Germany are high-quality, precise and wear-free (hardened and ground). Combined with ball screw spindles, ball screw nuts ensure that rotary motion is converted into linear motion at extremely low values of friction.

The ball screw nut is positioned and held in the clamping block using a stud screw. The ball screw nuts contain multiple circulating balls and an internal ball return mechanism.

Adjustment of the clamping block stud screw allows the ball screw spindle to move freely, without backlash.

Repeat accuracy is less than 0.01 mm on a length of 300 mm. The linear drive is lubricated via the grease nipple on the clamping block.

Ball screw spindles are roll manufactured using modern machines prior to hardening and polishing.

Our linear drives are technically advanced and have proven themselves over a period of more than 20 years of practical application.

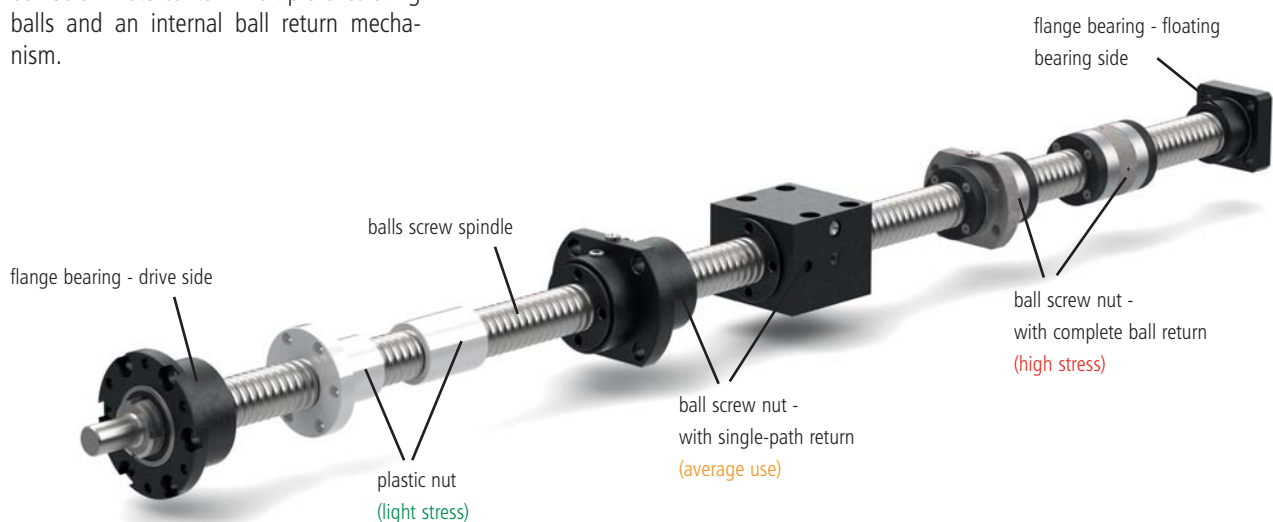

Contract Manufacturing

With more than 1 million units soled, "isel" has created core competence in the area of ball screws. Our drives are technically mature and have proved themselves in many applications in practical use. The specialist skills of our highly qualified employees are a significant contributing factor on our path to creating technically perfect and economically successful solutions. isel Germany AG offers products to meet every special customer requirement. Thanks to our very modern manufacturing plants, we are able to carry out all work processes (rolling, hardening and polishing) efficiently and according to the customer's specifications. They precisely meet the special requirements that you give to us. Please get in contact with us or give us a call to discuss your area of application or individual case. You will find us an attentive and skilled partner. Our in-house design department checks all technical requirements and works in close collaboration with the production engineers to ensure your order can be quickly and flexibly integrated into the production process.

Visit us on our website and look at our current product video:



The company isel Germany AG has been manufacturing ball screw spindles on modern CNC controlled production machines also using robotics for over 25 years. Included amongst our long-standing clients are companies from the areas of

- machine and equipment construction
- electronics industry
- wood-working
- medical technology
- semiconductor industry
- training and other related areas



Ball screw spindles

Ø 12, 16, 20, 25 mm



Features

- rolled, hardened and polished
- Material CF 53, inductively hardened (HRC 60±2)
- Length up to 3,052 mm available (Special length on request!)
- End machining to isel standard or according to customers specifications

Available length Ø 12

Without end machining in a grid of 100 mm

- 252 up to 3,052 mm
- Two-sided end machining in a grid of 100 mm
- 252 mm up to 3,052 mm

Available length Ø 16

Without end machining in a grid of 100 mm

- 352 up to 3,052 mm
- Two-sided end machining in a grid of 100 mm
- 368 mm up to 3,068 mm

Available length Ø 20

Without end machining in a grid of 100 mm

- 252 up to 3,052 mm
- Two-sided end machining in a grid of 100 mm
- 252 up to 3,052 mm

Available length Ø 25

Without end machining in a grid of 100 mm

- 500 up to 3,000 mm
- Two-sided end machining in a grid of 100 mm
- 295 up to 2,995 mm

Ordering key

2 1 1 X X X X X X X

Diameter
 2 = 12mm
 3 = 16mm
 4 = 25mm
 5 = 20mm

Spindle pitch
 2 = 2,5 mm (only for Ø 12,16mm)
 3 = 4 mm (only for Ø 16mm)
 4 = 5 mm
 5 = 10 mm (not at Ø 12mm)
 6 = 20 mm (not at Ø 12mm)

Lengths
 e.g. **045** = 452 mm
086 = 868 mm
305 = 3,052 mm (rounded to the final digit)

End machining
 0 = not machined
 1 = one-sided
 5 = both sided
 suitable for all feeds
 (Aluminium profile length +78 mm)

See „available length“ for permissible combinations!

Dimensioned drawing

	Spindle pitch	L [max.]	L1	L2	L3	L4	L5	M	D1	D2	D3	D4
Ø 12	2.5 / 5	3,052	10	19	34.5	19	-	M8x 1	6.35 h7	8 h6	7 h6	-
Ø 16	2.5 / 4 / 5 / 10 / 20	3,052	18	31	52	28	-	M10 x 0.75	8 h7	10 h6	12 h6	-
Ø 20	5 / 10 / 20	3,052	20	32	55	27.5	-	M12x 1	10 h7	12 h6	12/14 h6	-
Ø 25	5 / 10 / 20	3,052	25	37	69	26	16	M17x 1	15 h7	17 h6	15 j6	19 h11

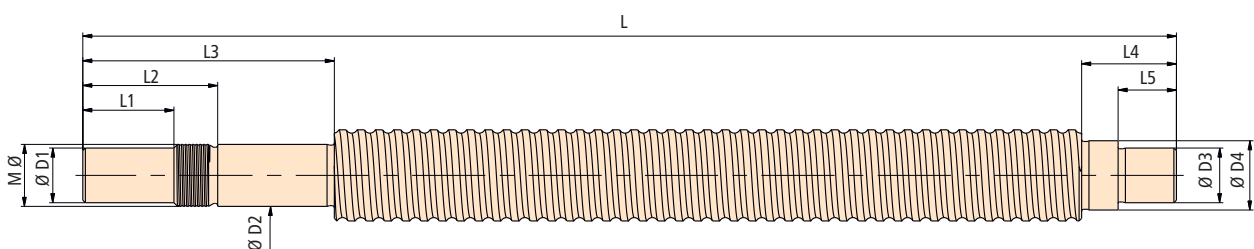

Plastic nuts round- or flange version for isel standard spindles

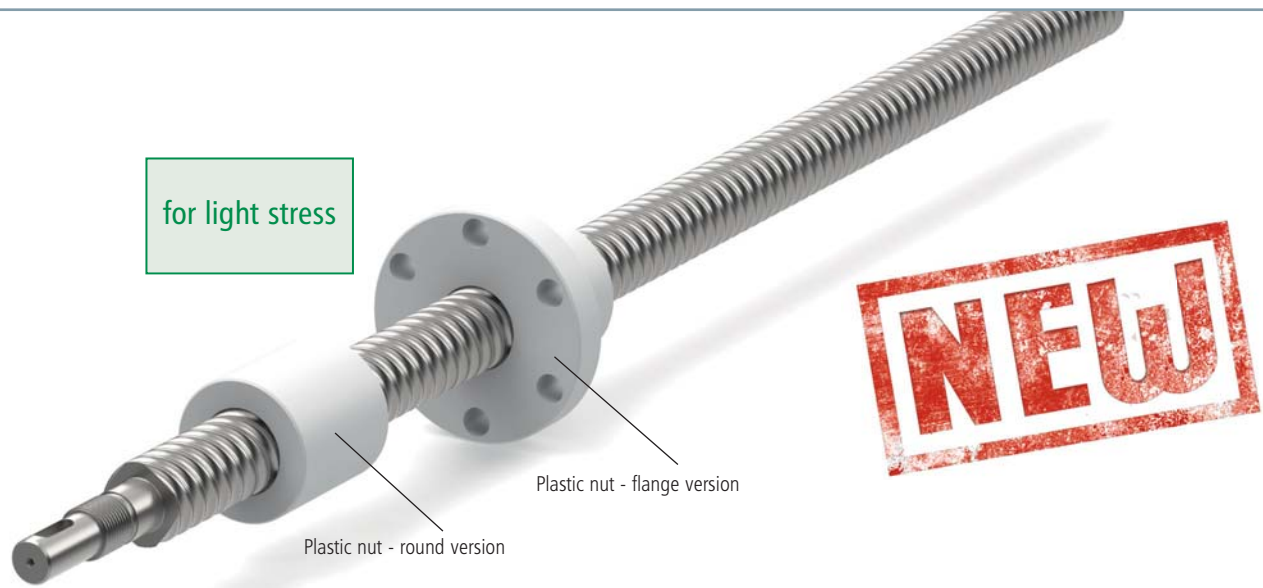

Technical data

Round nut

Item-No.	thread d1 x P	b1	d2	F axial (at V _{max.}) [N]	V _{max.} [mm/s] [feed]
213612 0025	12 x 2.5	25	24	123	33
213612 0050	12 x 5	25	24	123	66
213616 0050	16 x 5	30	28	179	50
213616 0100	16 x 10	30	28	179	100
213616 0200	16 x 20	30	28	179	199
213620 0050	20 x 5	35	33	238	40
213620 0100	20 x 10	35	33	235	80
213620 0200	20 x 20	35	33	235	159
213625 0050	25 x 5	40	32	381	32
213625 0100	25 x 10	40	32	381	64
213625 0200	25 x 20	40	32	386	127

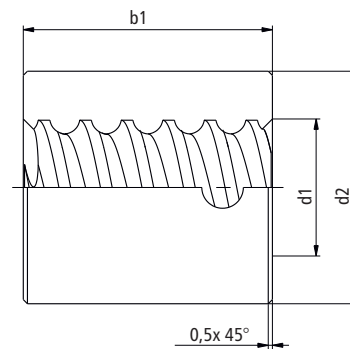

Flange nut

Item	thread d1 x P	d2	d3	d4	d5	b1	b2	F axial (at V _{max.}) [N]	V _{max.} [mm/s] [feed]
213812 0025	12 x 2.5	24	42	34	5	25	8	123	33
213812 0050	12 x 5	24	42	34	5	25	8	123	66
213816 0050	16 x 5	28	48	38	6	30	10	179	50
213816 0100	16 x 10	28	48	38	6	30	10	179	100
213816 0200	16 x 20	28	48	38	6	30	10	179	199
213820 0050	20 x 5	33	55	45	7	35	10	238	40
213820 0100	20 x 10	33	55	45	7	35	10	235	80
213820 0200	20 x 20	33	55	45	7	35	10	235	159
213825 0050	25 x 5	32	55	45	7	40	10	381	32
213825 0100	25 x 10	32	55	45	7	40	10	381	64
213825 0200	25 x 20	32	55	45	7	40	10	386	127

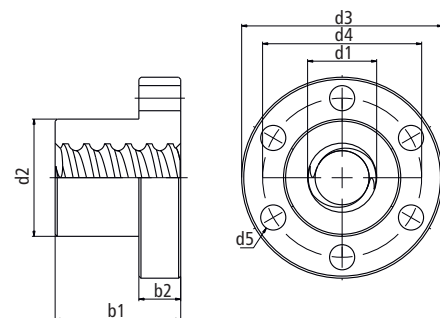

Ball screw nut with complete ball return

for average use

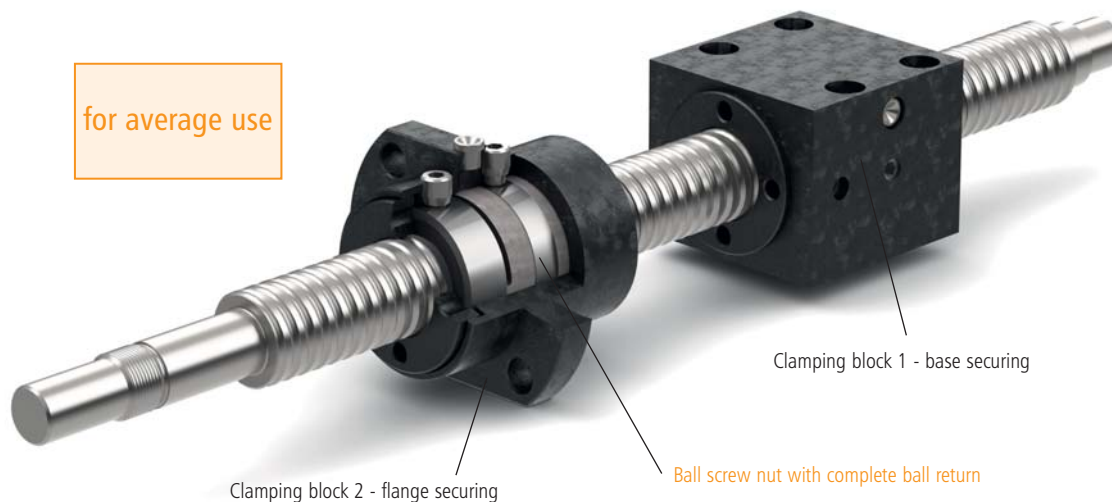

Clamping block 2 - flange securing

Clamping block 1 - base securing

Ball screw nut with complete ball return

Ordering data

Ø	Item-No.	spindle pitch	D	L	dynamic load [N]	static load [N]
12	213412 0003	2.5	24	37.5	3,000	1,900
	213412 0005	5	24	37.5	2,000	1,300
16	213503	2.5	28	50	3,500	5,500
	213514	4	28	50	4,600	7,200
	213505	5	28	50	4,600	7,200
	213510	10	28	50	4,200	6,500
	213520	20	28	50	2,500	1,900
20	213420 0005	5	33	50	9,000	5,000
	213420 0010	10	33	50	8,000	4,500
	213420 0020	20	33	50	3,500	2,200
25	213700 0005	5	38	50	5,100	12,600
	213700 0010	10	38	50	5,100	12,600
	213700 0020	20	38	70	3,570	8,800

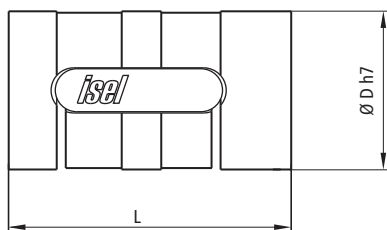

Features ball screw nuts

- Material 16MnCr5, sharpened
- version as round and flange nuts
- pitches: 2.5 / 5 / 10 / 20 mm
- with integrated end-cap ball return
- the version with pitch 20 mm is supplied with scrapers

Features clamping blocks

- Material steel, gunmetal finish
- versions for recirculating ball spindles Ø 12, 16, 20, 25 mm
- Nut pitches
 - 2.5 / 5 mm (Ø 12 mm)
 - 2.5 / 4 / 5 / 10 and 20 mm (Ø 16 mm)
 - 5 / 10 and 20 mm (Ø 20 mm)
 - 5 / 10 and 20 mm (Ø 25 mm)
- Clamping blocks for base and flange securing

... and suitable clamping blocks

Ordering data and dimensioned drawings of the clamping blocks

Base securing

	Item-No.	M	L	B	H	H1	L1	L2	L3	Clamping nut
Ø 12	213400	24	37.5	44	29	14.5	7	20	31	-
Ø 16	213500	28	54	47	33	16.5	14.5	25	35	-
Ø 20	213600	33	61.5	53	40	20	10	30	40	1x
Ø 25 - pitch 5/10	213700 9001	38	60	60	49.5	25	10	30	46	1x
Ø 25 - pitch 20	213700 9002	38	80	60	50	25	10	50	46	1x

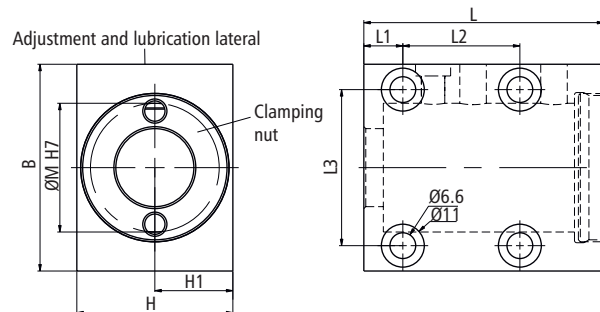

Flange securing

	Item-No.	M	L	B	H	d	T	D1	D2	D3	L1	L2	Clamping nut
Ø 12	213401	24	37.5	53	42	4.5	45	35	37 g6	35	3	24.5	-
Ø 16	213501	28	50	62	48	6.6	51	39	40 g6	39	11.6	28.4	-
Ø 20	213601	33	60.5	67	53	6.6	56	44	45 g6	44	16	34.5	1x
Ø 25 - pitch 5/10	213700 9003	38	60	80	62	9	65	49	50 f9	50 f9	32.25	17.75	1x
Ø 25 - pitch 20	213700 9004	38	80	80	62	9	65	49	50 f9	50 f9	52.25	17.75	1x

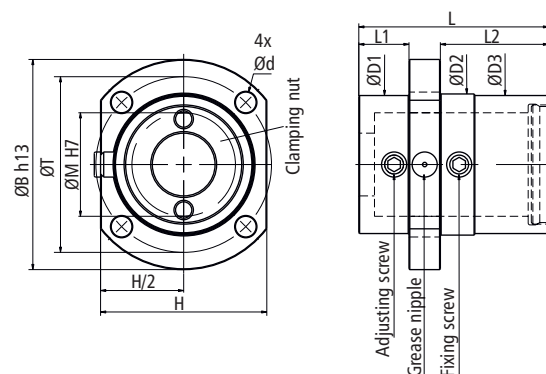

Ball screw nut with complete ball return

for high loads

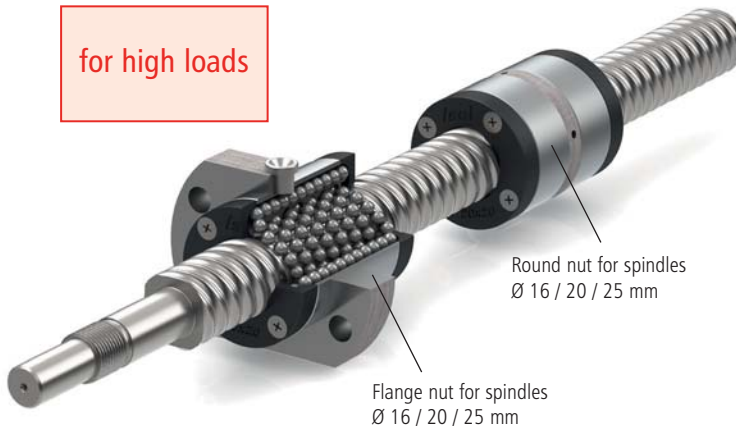

Features

- Material 16MnCr5, sharpened
- version as round nut or flange nut
- pitch: 20 mm
- with integrated end-cap ball return

Dimensioned drawings

Round nut

Ø	Item-No.	pitch	d2	d1	Ø D _{h7}	L	L ₁	M	L ₂	dynamic load factor	static load factor
16	211336 0020	20	16	10	30	45,5	33,5	M8 x 0,75	22,5	13.000 N	29.000 N
20	211356 0020	20	20	14	35	46,5	34,5	M8 x 0,75	25,5	15.000 N	35.000 N
25	211346 0020	20	25	21	40	50	35	M10 x 0,75	28,3	16.000 N	40.000 N

Flange nut

Ø	Item-No.	pitch	d2	d1	D1 g ₆	LB	L1	L3	L8 h ₁₃	D4	D6 h ₁₃	D5	dynamic load factor	static load factor
16	211236 0020	20	16	10	30	45,5	10	6	40	38	48	6x Ø5,5	13.000 N	29.000 N
20	211256 0020	20	20	14	35	46,5	10	11	44	47	58	4x Ø 6,6	15.000 N	35.000 N
25	211246 0020	20	25	21	40	50	10	12,5	48	51	62	4x Ø6,6	16.000 N	40.000 N

Round nut

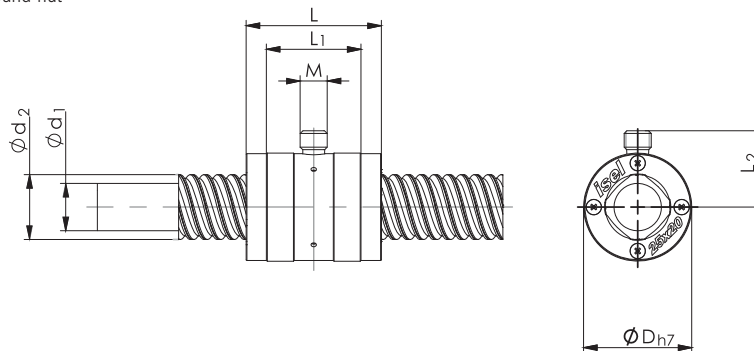

Flange nut

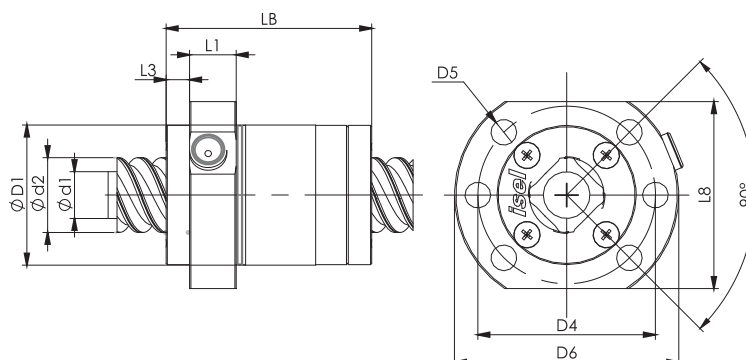

Flange bearings



flange bearing - drive side



flange bearing - floating bearing side

Features

- Bearing, spindle drive side(fixed bearing side) and the spindle floating bearing side
- Flange bearing, drive side: bushing with two pressed angular contact ball bearings in an O-configuration
- Flange bearing, floating bearing side (counter-bearing): bushing with pressed needle bearing

Ordering data and dimensioned drawings

Drive side and locking nut

	Version	Item-No.	B	L	L1	D1	D2	T1	T2	G1	G2	d	Thread
Ø 12	angular	216504 0030	40	19.5	8	35	8	38.2	-	45°	90°	4x Ø 4.5	-
Ø 16	angular	216504 0001	45	23	6	35	10	45	-	45°	90°	4x Ø 12 x 4U / Ø 7	-
Ø 16	round	216504 0003	62	23	6	35	10	45	54	45°	90°	4x Ø 12 x 4U / Ø 7	4x M6
Ø 20	round	216504 0031	64	23	8	39.5	12	50	54	45°	90°	4x Ø 12 x 4U / Ø 7	4x M6
Ø 25	round	216504 0006	72	34	8	53	17	62	62	30°	60°	6x Ø 12 x 4U / Ø 7	6x M6

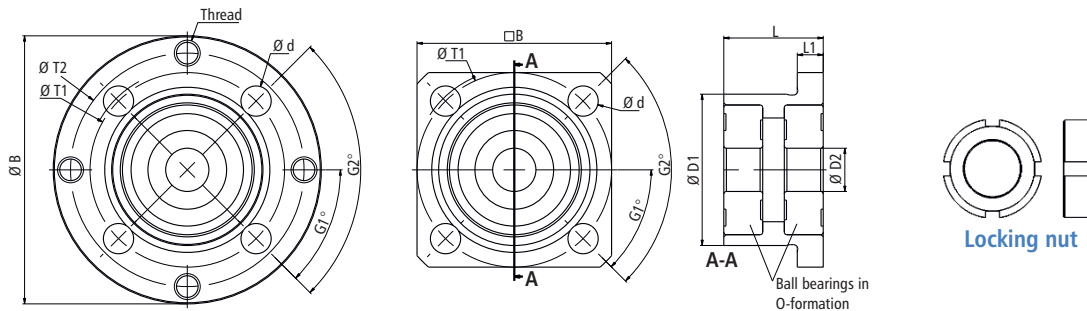

Floating bearing side

	Item-No.	B	L	L1	L2	L3	L4	D1	D2	T	d
Ø 12	216504 0032	35	20	8	6	6.5	0.5	28	7	38.2	Ø7.5 x 4U Ø4.5
Ø 16	216504 0002	45	29	12	4.5	9.5	0.5	35	12	45	Ø12 x 4U Ø7
Ø 20	216504 0033	50	29.5	12	4.5	5	1.5	35	12	50	Ø12 x 4U Ø7
Ø 25	216504 0005	45	29	12	8	10	0	35	15	45	Ø12 x 4U Ø7

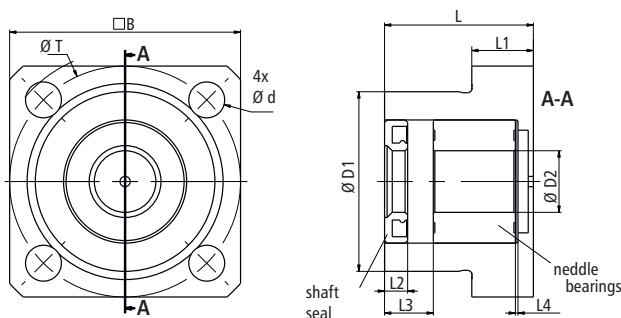

Bearing supports

Bearing support 1

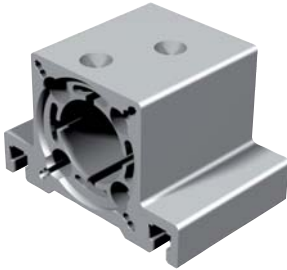

- Aluminium profile compliant with DIN EN 12020-2
- As a parallel connection between the flange bearing and motor flange
- Flat milled securing surfaces
- Version for recirculating ball spindle \varnothing 16 mm
- Universal securing options

Part no.: **216504 0007**

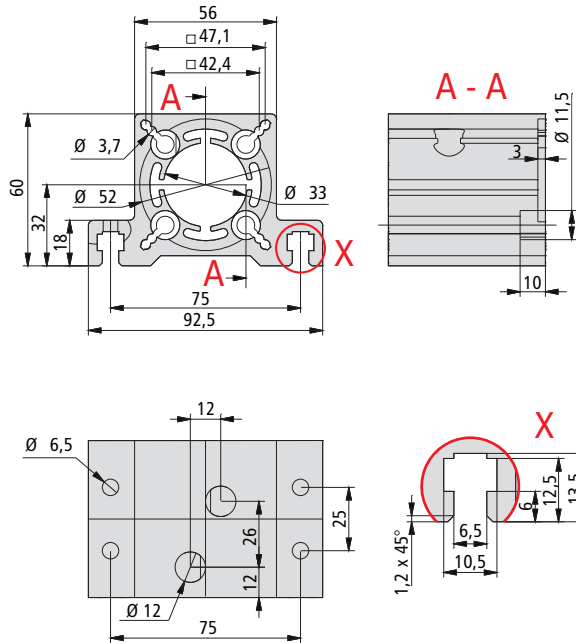

Bearing support 2

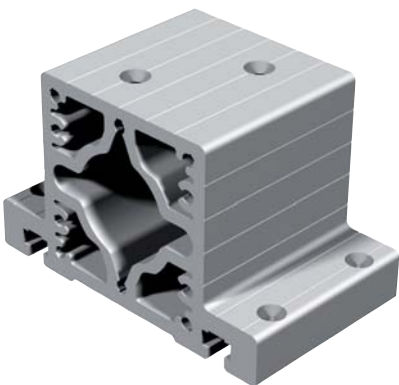

- Aluminium profile compliant with DIN EN 12020-2
- As a parallel connection between the flange bearing and motor flange
- Version for recirculating ball spindle \varnothing 25 mm
- Universal securing options

Part no.: **216504 0008**

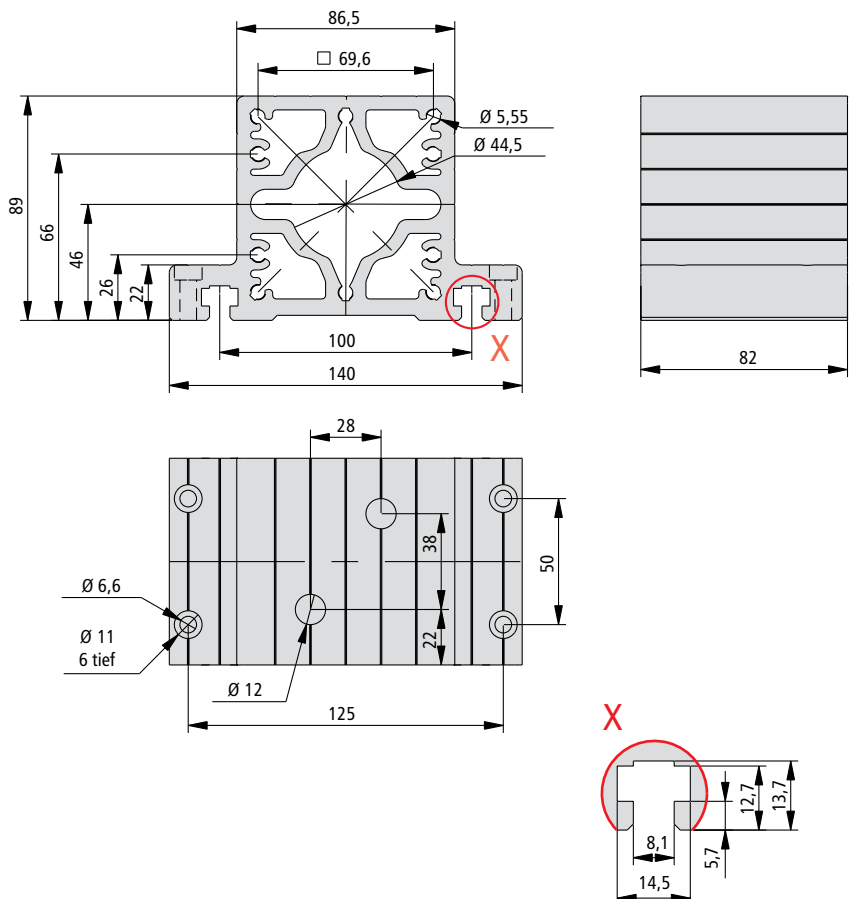

Shaft couplings

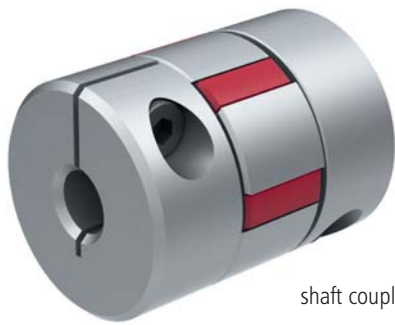

shaft couplings

Features

- Shaft couplings made of aluminium
- \varnothing 20, 30 or 40 mm
- Set of two shaft coupling halves, three PUR sprockets (86 °, 92 ° and 98 ° Shore hardness) and corresponding clamping screws

Ordering data



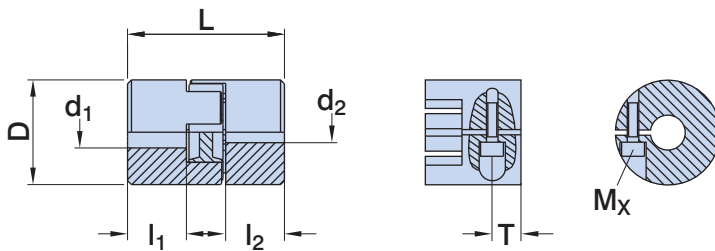

Coupling	Part-no.	Dimensions [mm]						Clamping screw		
		d ₁	d ₂	D	L	l ₁ / l ₂	d ₁ / d ₂	M _x	T	Screw torque [Nm]
20/30	218001 5060	5.0	6.0	20	30	10	4 - 7	M3	5	0.76
	218001 9999	from 4 to 7 mm								
30/40	218002 6380	6.35	8.0	30	40	14	6 - 13	M4	5	1.34
	218002 8080	8.0	8.0							
	218002 9999	from 6 to 13 mm								
40/60	218003 9580	9.52	8.0	40	60	22,5	8 - 18	M5	12	3.05
	218003 9999	from 8 to 18 mm								



Size	Shore hardness	Revolutions per minute V=30 m/s	Torque			Static torsion spring stiffness [Nm/rad]	Torsion spring stiffness [N/mm]	Mass moment of inertia [kgm ²]	
			T _{Ksp}	T _{KN}	T _{Kmax}			per hub	toothed rim
20/30	86	28.000	0,45	2,2	4,5	22,6	183	0,49 - 10 ⁻⁶	0,079 - 10 ⁻⁶
	92			3,0	6,0	31,5	262		
	98			5,0	10,0	51,6	518		
30/40	86	19.000	1,0	5,5	11,0	82,4	226	2,8 - 10 ⁻⁶	0,457 - 10 ⁻⁶
	92			7,5	15,0	114,6	336		
	98			12,5	25,0	171,9	604		
40/60	86	14.000	2,5	6,9	14,0	415,0	780	20,4 - 10 ⁻⁶	1,49 - 10 ⁻⁶
	92			10,0	20,0	573,0	1120		
	98			17,0	34,0	859,5	2010		

Linear units

Overview

LES functional overview		B-44
LES 4 with spindle drive		B-46
LES 6 with spindle drive		B-48
LES 5 with spindle drive		B-50
Calculations		B-52
Combination examples		B-54
Motor modules		B-56
Clutch housing		B-57
Motor leads		B-58
Installation kit <small>with angular transmission</small>		B-62
Slots/crossbench plates		B-64
T-slot plates		B-67
Angles brackets		B-68
Accessories		B-71
iLD 50-6 with linear motor		B-72

Linear units

Overview

LEZ functional overview

B-74

LEZ 1

with toothed belt drive



B-76

LEZ 1G Blue Line

with toothed belt drive



B-78

LEZ 2

with toothed belt drive



B-80

LEZ 3

with toothed belt drive



B-82

LEZ 9

with toothed belt drive



B-84

Accessories

B-86

Example in use

B-87

CAD data can be found on



Functional overview

at example LES 5

Plastic cap
electromagnetically shielded

Clamping surface
milled flat

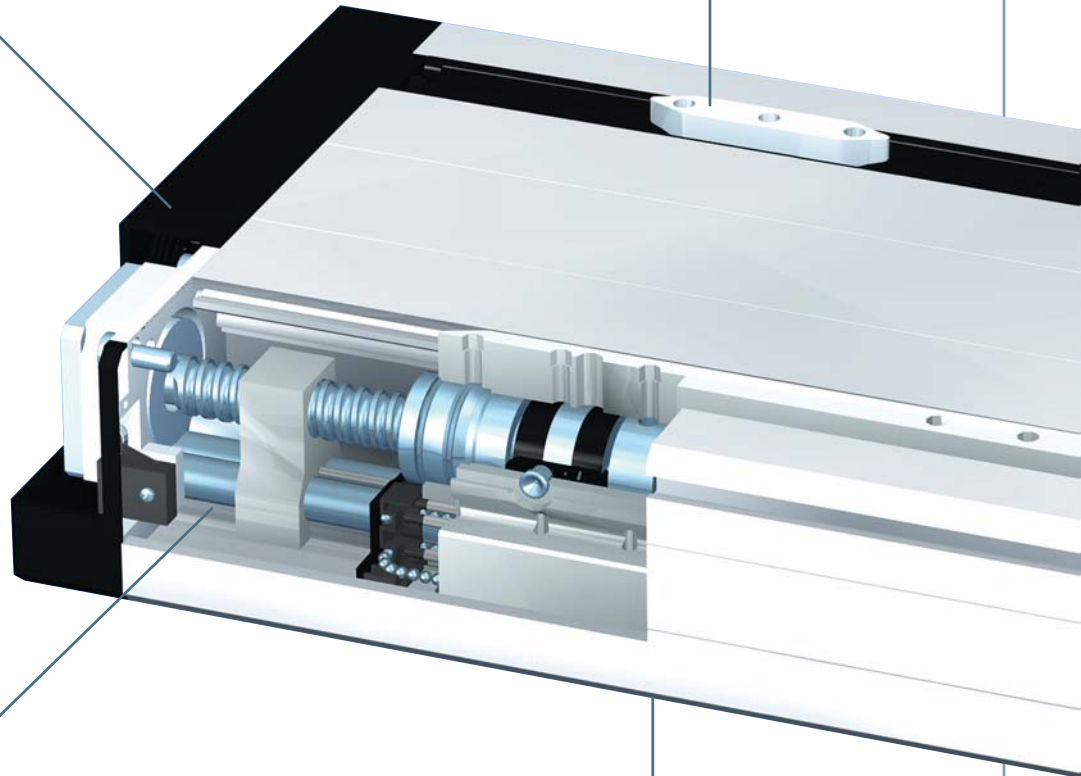

Shaft housing outline
precision milled

Profile underside
milled flat

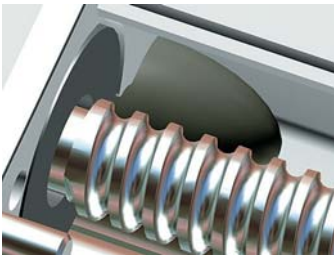

- End position buffering both sides with soft PVC parabolic springs
- Counter-bearing with 2 needle sleeves

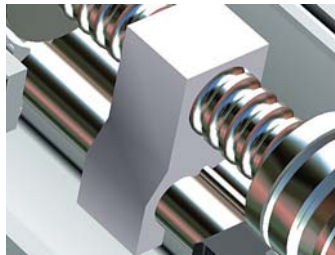

- Spindle support from a profile length of 1500 mm without limiting the process range

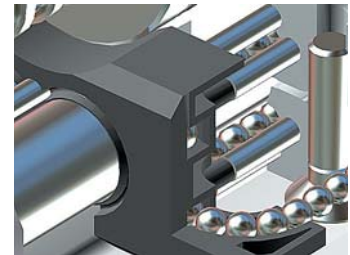

- Recirculating ball in patented aluminium linear slides
- Glass fibre reinforced loop components with scrapers

Functional overview

at example LES 5

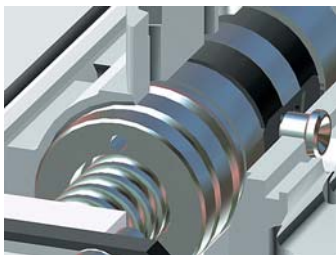
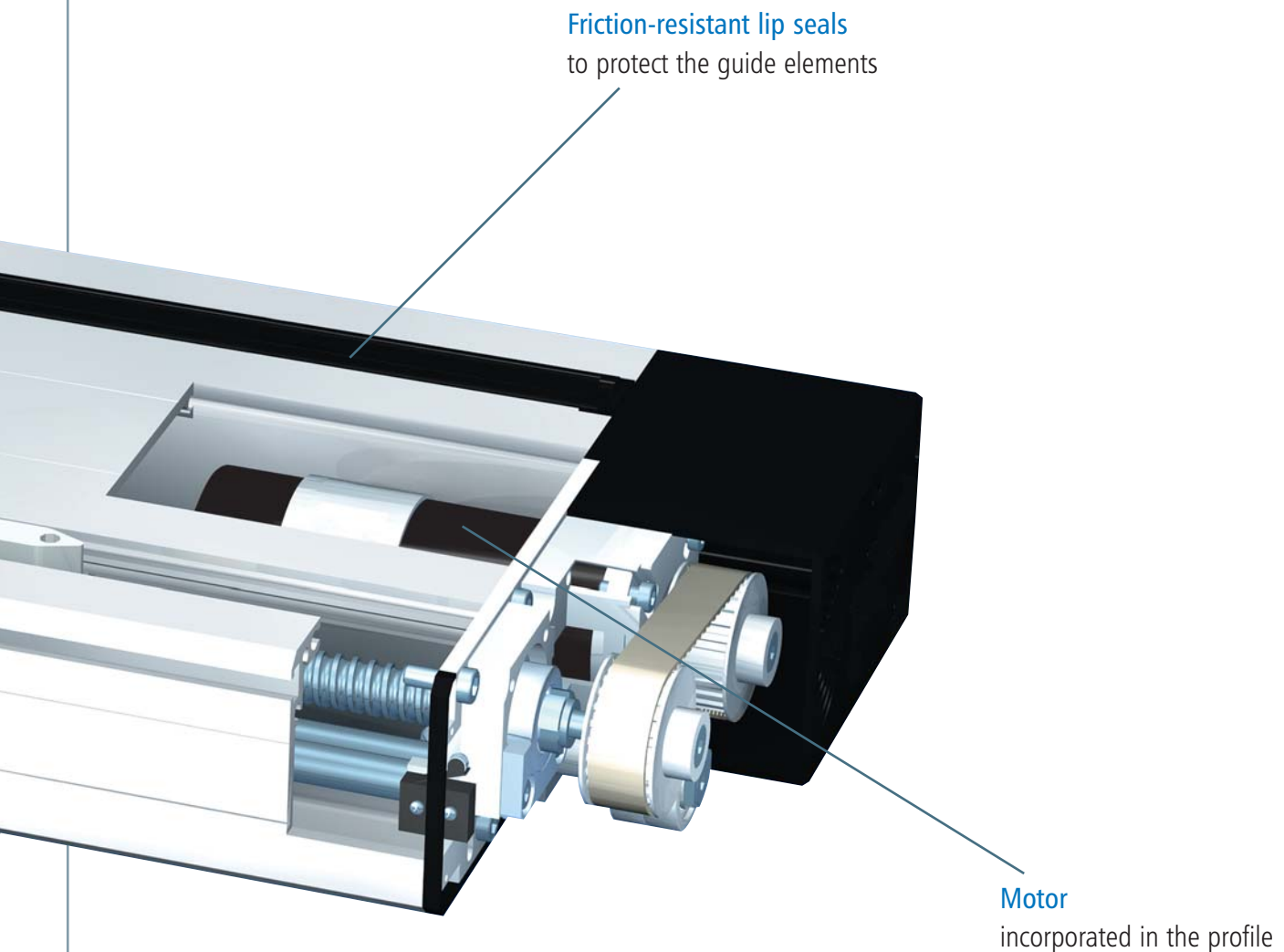

- Preset play-free recirculating ball nut with scrapers
- Central lubrication system for recirculating ball nut and circulations

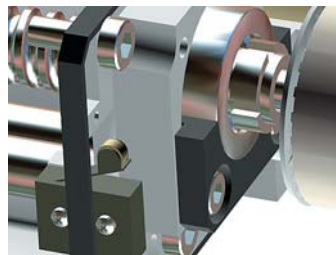

- Integrated overrun limit switch
- Spindle bearing with angular contact bearings
- Axially free from play by means of self-locking special nuts

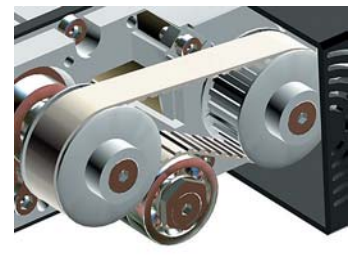

- Belt return and connecting electronics covered completely by protective cap

Linear units with spindle drive

LES 4



LES 4 with side-mounted belt drive module

Features

- Aluminium shaft housing profile W75 × H75 mm, naturally anodised
- Clamping area and profile underside milled flat
- with 2 precision steel shafts Ø 12 h6, material Cf53, Hardness 60 ± 2 HRC
- Aluminium shaft slides WS 5/70, 2 x WS 5/70 (70 mm long), adjustable for no play, central lubrication system
- Recirculating ball drive 2.5/4/5/10 and 20 mm pitches
- Profile sealing with friction-resistant lip seals
- Cast aluminium end plates
- With 2 limit or reference switches, Repeat accuracy ± 0.02 mm
- Sealed angular contact bearings in drive - steel flange

Options:

- Black anodized aluminium profile
- Electromagnetic brakes in the motor module or in drive spindle extension
- Steel slide LS2 (Part no. 223007)
- External limit switch attachment set (see accessories)

Available on request:

- Length measuring system
- Bellows gaiter cover
- Assembly left of the motor module

Ordering key

2 3 4 X X X 0 X X X

Drive

- 0 = Preparation Direct drive modules
- 1 = Preparation Belt drive module

Shaft slides

- 0 = 1 Shaft slides 70 mm
- 1 = 1 Shaft slides 200 mm
- 2 = 2 Shaft slides 70 mm

Profile length (L1)

e.g. 029 = 290 mm (min.)
299 = 2990 mm (max.)

(rounded to the last digit)

Standard profile lengths available in 100 mm raster

Recirculating ball drive

- 0 = without
- 1 = Pitch 2.5 mm
- 2 = Pitch 4.0 mm
- 3 = Pitch 5.0 mm
- 4 = Pitch 10 mm
- 5 = Pitch 20 mm
- 6 = Pitch 20 mm (with complete ball return)

Drive modules

see pages 2-66 et seq. of the catalogue

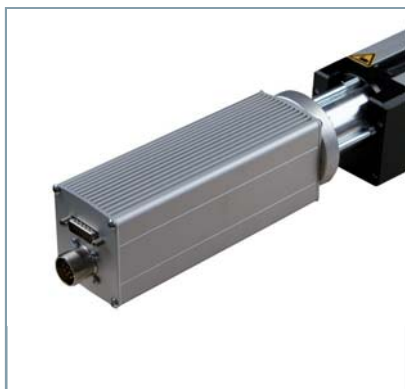

Technical specification

Aluminium profile

Aluminium profile LES 4	
Moment of inertia I _x	107.711 cm ⁴
Moment of inertia I _y	125.843 cm ⁴
*Centre of gravity <small>see dimensioned drawing</small>	33.23 mm
Cross-sectional area	18.81 cm ²
Material	AlMgSi0, 5F22
Anodising	E6/EV1
Weight with steel shafts	6.2 kg/m
Weight with steel shafts and spindles	7.6 kg/m

No load running torques

No load torques (Ncm)					
Speed (rpm)	Spindle pitch				
	2.5	4	5	10	20
500	15	15	16	17	18
1500	19	19	19	20	21
3000	23	24	24	25	26

Linear units with spindle drive

LES 4

Bending

Load config. 1

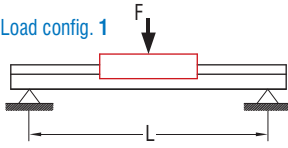

Load config. 2

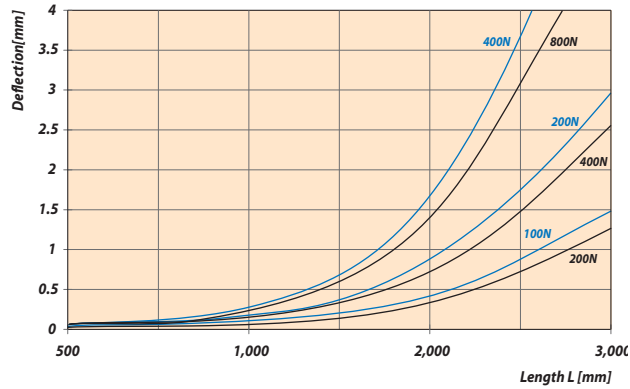
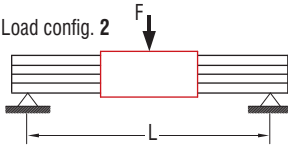

Load factors

$$F_r(\alpha) = \frac{F_2}{\cos \alpha}$$

$$F_r(\alpha) = \frac{F_1}{\sin \alpha}$$

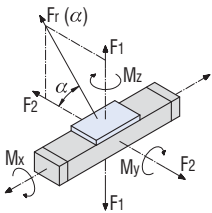

LES 4 with one WS 5/70	
C_0	2,576.65 N
C	1,461.14 N
F_1 stat.	2,200.67 N
F_1 dyn.	1,247.93 N
F_2 stat.	2,576.65 N
F_2 dyn.	1,461.14 N
M_x stat.	36.45 Nm
M_y stat.	82.16 Nm
M_z stat.	96.20 Nm
M_x dyn.	20.67 Nm
M_y dyn.	46.59 Nm
M_z dyn.	54.55 Nm

LES 4 with two WS 5/70	
C_0	4,954.5 N
C	2,809.5 N
F_1 stat.	4,231.5 N
F_1 dyn.	2,398.5 N
F_2 stat.	4,954.5 N
F_2 dyn.	2,809.5 N
M_x stat.	44.7 Nm
M_y stat.	126.945 Nm
M_z stat.	148.635 Nm
M_x dyn.	25.2 Nm
M_y dyn.	71.955 Nm
M_z dyn.	84.285 Nm

permissible spindle speeds

LES 4 / 5 / 6	Spindle pitch p [mm]	max. permissible feed speed v permissible [mm/s]				
		2.5	4	5	10	20
Profile length L [mm]	max. permissible spindle speed n [rpm]					
490	4000	167	267	333	667	1333
990	3000	125	200	250	500	1000
1390	1500	63	100	125	250	500
1490 *	3000	125	200	250	500	1000
1990 *	1650	69	110	138	275	550
2490 *	1050	44	70	88	175	350
2990 *	750	31	50	63	125	250

* with spindle support

dimensioned drawing

process travel

at 1 × WS 5/70 = L1 -150 mm
at 2 × WS 5/70 = L1 -280 mm

external limit switches see pages B-71

LES 4 with one WS 5/70	
C_0	2576.65 N
C	1461.14 N
F_1 stat.	2200.67 N
F_1 dyn.	1247.93 N
F_2 stat.	2576.65 N
F_2 dyn.	1461.14 N
M_x stat.	36.45 Nm
M_y stat.	82.16 Nm
M_z stat.	96.20 Nm
M_x dyn.	20.67 Nm
M_y dyn.	46.59 Nm
M_z dyn.	54.55 Nm

dimensioned drawing

Aluminium profile

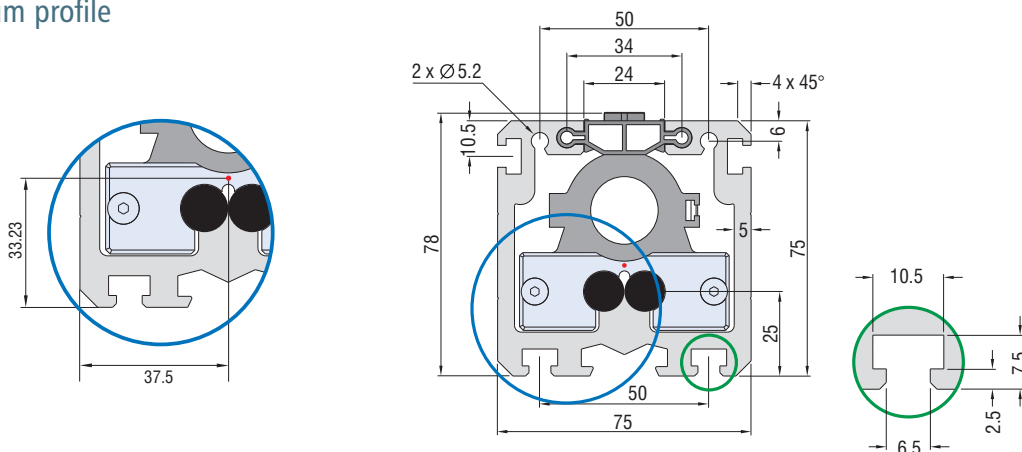

Linear units with spindle drive

LES 6



LES 6 with side belt drive module

Features

- Aluminium shaft housing profile W150 × H75 mm, naturally anodised
- Clamping area and profile underside milled flat
- With 4 precision steel shafts Ø 12 h6, material Cf53, Hardness 60 ± 2 HRC
- Aluminium shaft slides WS 5/70, 2 x WS 5/70 (70 mm long), adjustable for no play, central lubrication system
- Recirculating ball drive 2.5/4/5/10 and 20 mm pitches
- Profile sealing with friction-resistant lip seals
- Cast aluminium end plates
- With 2 limit or reference switches, Repeat accuracy ± 0.02 mm
- Sealed angular contact bearings in drive - steel flange

Ordering key

2 3 4 X X X 0 X X X

Drive

- 6 = Preparation Direct drive modules
- 7 = Preparation Belt drive module

Shaft slides

- 0 = 2 Shaft slides 70 mm
- 1 = 2 Shaft slides 200 mm
- 2 = 4 Shaft slides 70 mm

Profile length (L1)

- e.g. 029 = 290 mm (min.)
- 299 = 2990 mm (max.) (rounded to the last digit)

Standard profile lengths available in 100 mm raster

Recirculating ball drive

- 0 = without
- 1 = Pitch 2.5 mm
- 2 = Pitch 4.0 mm
- 3 = Pitch 5.0 mm
- 4 = Pitch 10 mm
- 5 = Pitch 20 mm
- 6 = Pitch 20 mm (with complete ball return)

Options:

- Black anodized aluminium profile
- Electromagnetic brake
- Steel slides LS2 (Part no. 223007)
- Limit switch attachment kit (see accessories)

To order:

- Length measuring system
- Bellows gaiter cover
- Assembly left of the motor module

Drive modules

see pages 2-68 et seq. of the catalogue



Technical specification

Aluminium profile

Aluminium profile LES 6	
Moment of inertia I _x	707.100 cm ⁴
Moment of inertia I _y	212.200 cm ⁴
*Centre of gravity <small>see dimensioned drawing</small>	32.78 mm
Cross-sectional area	30.07 cm ²
Material	AlMgSi0, 5F22
Anodising	E6/EV1
Weight with steel shafts	11.4 kg/m
Weight with steel shafts and spindles	12.8 kg/m

No load running torques

No load torques (Ncm)					
Speed (rpm)	Spindle pitch				
	2.5	4	5	10	20
500	17	17	18	20	21
1500	20	20	22	24	25
3000	24	25	26	29	30

Linear units with spindle drive

LES 6

Bending

■ Load config. 1

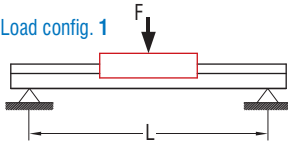

■ Load config. 2

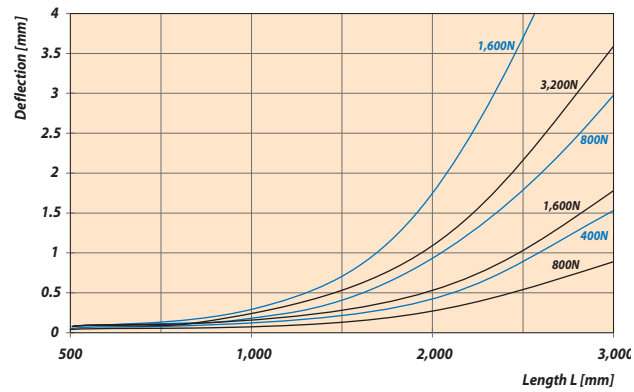
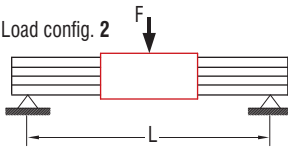

Load factors

$$F_r(\alpha) = \frac{F_2}{\cos \alpha}$$

$$F_r(\alpha) = \frac{F_1}{\sin \alpha}$$

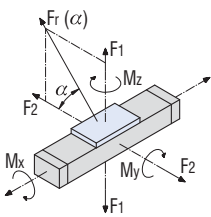

LES 6 with two WS 5/70	
C_0	5,153.30 N
C	2,319.41 N
F_1 stat.	4,401.33 N
F_1 dyn.	1,980.96 N
F_2 stat.	5,153.30 N
F_2 dyn.	2,319.14 N
M_x stat.	211.54 Nm
M_y stat.	164.31 Nm
M_z stat.	192.39 Nm
M_x dyn.	95.21 Nm
M_y dyn.	73.95 Nm
M_z dyn.	86.59 Nm

LES 6 with four WS 5/70	
C_0	6,606 N
C	3,746 N
F_1 stat.	5,642 N
F_1 dyn.	3,198 N
F_2 stat.	6,606 N
F_2 dyn.	3,746 N
M_x stat.	211.575 Nm
M_y stat.	366.73 Nm
M_z stat.	429.39 Nm
M_x dyn.	119.925 Nm
M_y dyn.	207.87 Nm
M_z dyn.	243.49 Nm

permissible spindle speeds

LES 4 / 5 / 6 Profil length L [mm]	Spindle pitch [mm]	2.5	4	5	10	20
		max. permissible feed speed v permissible [mm/s]				
490	4000	167	267	333	667	1333
990	3000	125	200	250	500	1000
1390	1500	63	100	125	250	500
1490 *	3000	125	200	250	500	1000
1990 *	1650	69	110	138	275	550
2490 *	1050	44	70	88	175	350
2990 *	750	31	50	63	125	250

* with spindle support

dimensioned drawing

process travel
at 2xWS 5/70 = L1 -150 mm
at 4xWS 5/70 = L1 -280 mm

external limit switches see page B-71

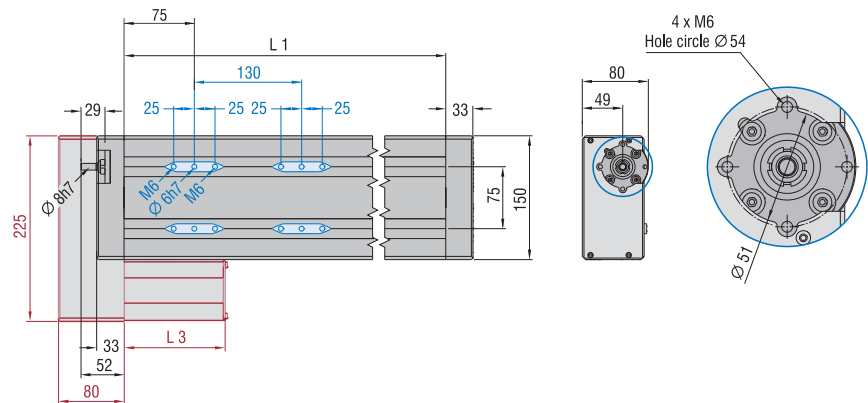

dimensioned drawing Aluminium profile

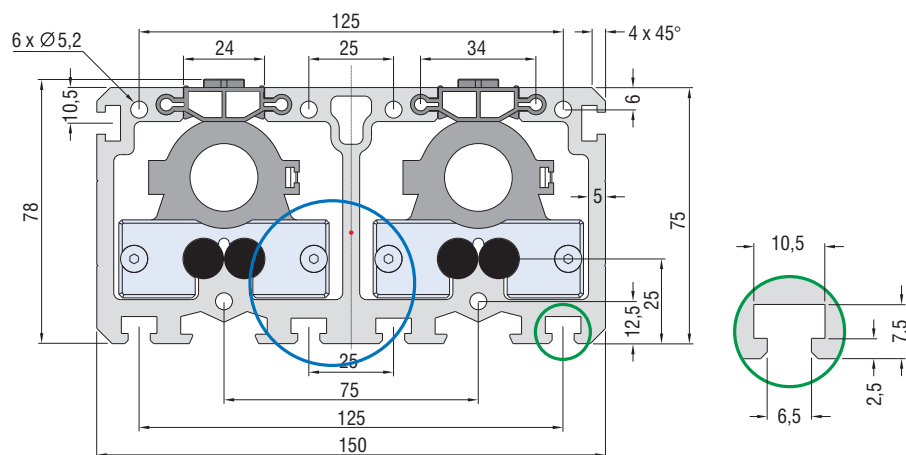
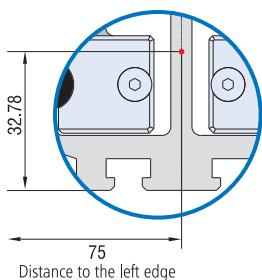

Linear units with spindle drive

LES 5



LES 5 with integrated belt drive module

Features

- Aluminium shaft housing profile W225 × H75 mm, naturally anodised
- Clamping area and profile underside milled flat
- With 4 precision steel shafts Ø 12 h6, material Cf53, Hardness 60 ± 2 HRC
- Aluminium shaft slides WS 5/70, 2 x WS 5/70 (70 mm long), adjustable for no play, central lubrication system
- Recirculating ball drive 2.5/4/5/10 and 20 mm pitches
- Profile sealing with friction-resistant lip seals
- Cast aluminium end plates
- With 2 limit or reference switches, Repeat accuracy ± 0.02 mm
- Sealed angular contact bearings in drive - steel flange

Ordering key

2 3 4 X X X 0 X X X

Drive

- 3 = Preparation Direct drive modules
- 4 = Preparation Belt drive module

Shaft slides

- 0 = 2 Shaft slides 70 mm
- 1 = 2 Shaft slides 200 mm
- 2 = 4 Shaft slides 70 mm

Profile length (L1)

e.g. 029 = 290 mm (min.)
299 = 2990 mm (max.)
(rounded to the last digit)
Standard profile lengths available in 100 mm raster

Recirculating ball drive

- 0 = without
- 1 = Pitch 2.5 mm
- 2 = Pitch 4.0 mm
- 3 = Pitch 5.0 mm
- 4 = Pitch 10 mm
- 5 = Pitch 20 mm
- 6 = Pitch 20 mm (with complete ball return)

Options:

- Black anodized aluminium profile
- Electromagnetic brake
- Steel slides LS2 (Part no. 223007)
- Limit switch attachment kit (see accessories)

Available on request:

- Length measuring system
- Bellows gaiter cover

Drive modules

see pages 2-66 et seq. of the catalogue



Technical specification

Aluminium profile

Aluminium profile LES 5	
Moment of inertia I _x	2,361.654 cm ⁴
Moment of inertia I _y	298.925 cm ⁴
*Centre of gravity <small>see dimensioned drawing</small>	33.39 mm
Cross-sectional area	42.49 cm ²
Material	AlMgSi0, 5F22
Anodising	E6/EV1
Weight with steel shafts	13.8 kg/m
Weight with steel shafts and spindles	15.2 kg/m

No load running torques

Speed (rpm)	No load torques (Ncm)				
	Spindle pitch				
	2.5	4	5	10	20
500	15	15	16	17	18
1500	19	19	19	20	21
3000	23	24	24	25	26

Linear units with spindle drive

LES 5

Bending

■ Load config. 1

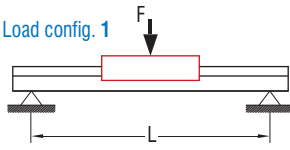

■ Load config. 2

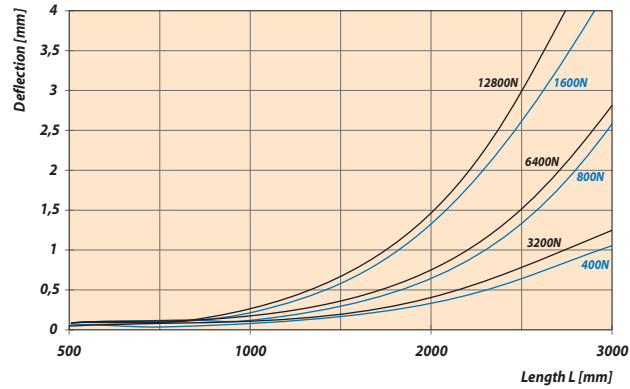
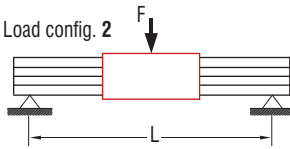

Load factors

$$F_r(\alpha) = \frac{F_2}{\cos \alpha}$$

$$F_r(\alpha) = \frac{F_1}{\sin \alpha}$$

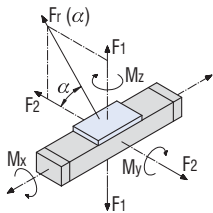

LES 5 with two WS 5/70		LES 5 with four WS 5/70	
C_0	5,153.30 N	C_0	6,606 N
C	2,319.41 N	C	3,746 N
F_1 stat.	4,401.33 N	F_1 stat.	5,642 N
F_1 dyn.	1,980.96 N	F_1 dyn.	3,198 N
F_2 stat.	5,153.30 N	F_2 stat.	6,606 N
F_2 dyn.	2,319.14 N	F_2 dyn.	3,746 N
M_x stat.	376.59 Nm	M_x stat.	423.15 Nm
M_x dyn.	169.49 Nm	M_x dyn.	239.85 Nm
M_y stat.	164.31 Nm	M_y stat.	366.73 Nm
M_y dyn.	73.95 Nm	M_y dyn.	207.87 Nm
M_z stat.	192.39 Nm	M_z stat.	429.39 Nm
M_z dyn.	86.59 Nm	M_z dyn.	243.49 Nm

Permissible spindle speeds

LES 4 / 5 / 6 Profil length L [mm]	Spindle pitch p [mm]	max. permissible spindle speed n [rpm]					max. permissible feed speed v permissible [mm/s]				
		2.5	4	5	10	20	167	267	333	667	1333
490	4000	167	267	333	667	1333					
990	3000	125	200	250	500	1000					
1390	1500	63	100	125	250	500					
1490 *	3000	125	200	250	500	500					
1990 *	1650	69	110	138	275	550					
2490 *	1050	44	70	88	175	350					
2990 *	750	31	50	63	125	250					

* with spindle support

Dimensioned drawing

Process travel

at 2xWS 5/70 = L1 -150 mm
at 4xWS 5/70 = L1 -280 mm

external limit switches see pages B-71

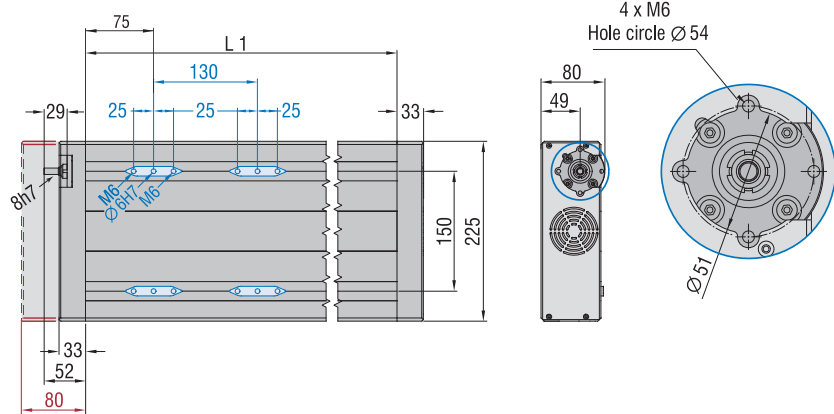

Dimensioned drawing

Aluminium profile

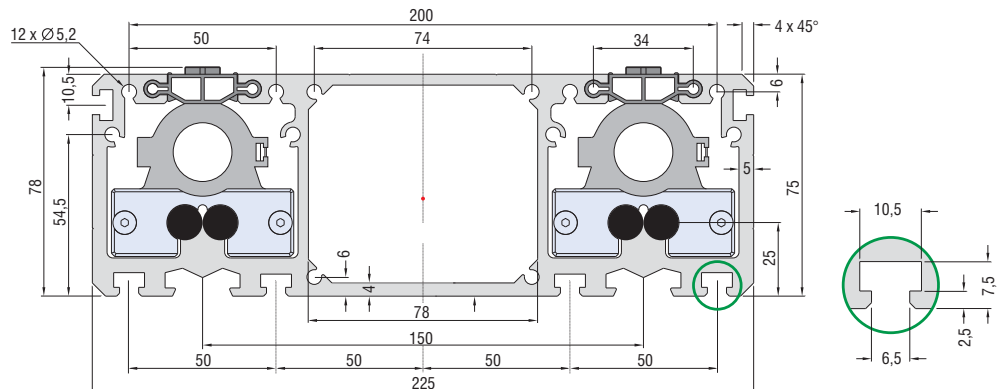

Theoretically critical speed

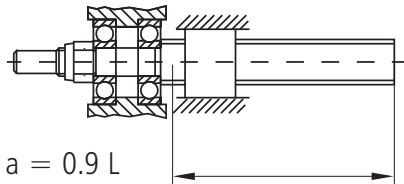
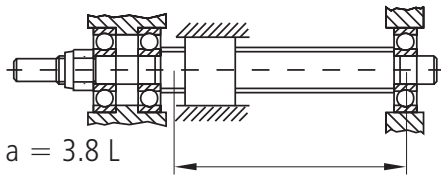

Definitions

- $n_{perm.}$ [min^{-1}] maximum permissible speed
- a Installation coefficient
- d_2 [mm] Spindle core diameter
- L [mm] Spindle length between the spindle bearings and spindle ends

Calculations

Critical speed

In most applications, you need to check tapped spindles at their critical speed.

The critical speed is that speed which causes resonance oscillations of this spindle.

This critical speed depends on the core diameter, the free load-bearing length and on the way the tapped spindle is constructed.

Given a general safety factor of 0.8, the maximum permissible speed can be calculated as follows:

$$n_{perm} = 392 \cdot \frac{a \cdot d_2}{L^2} 10^5$$

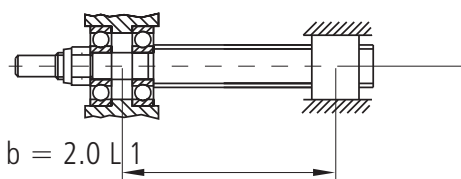
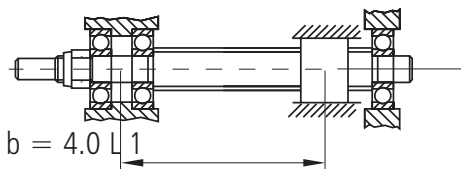

Definitions

- F_{perm} [N] permissible compressive loading
- d_2 [mm] Spindle core diameter
- L_1 [mm] free buckling length, i.e. the maximum distance between the central bearing and the centre of the tapped nut
- b Installation coefficient

Buckling load

The recirculating ball spindle should as far as possible be subjected only to tensile stress. If it is subjected to compressive loads, then the spindle may buckle.

With a safety factor of 3.0 against buckling, the result is

$$F_{zul} = \frac{34\,000 \cdot b \cdot d_2^4}{L_1^2}$$

Drive dimensioning

Calculations

Drive torque calculation

The required drive torque is made up of

- Load torque M_{load}
- Acceleration torques M_{trans} and M_{rot}
- No load torque $M_{no\ load}$

$$M_A = M_{load} + M_{trans} + M_{rot} + M_{no\ load}$$

Load torque

$$M_{last} = \frac{F_x \cdot p}{2 \cdot \pi \cdot 1000}$$

with feed force $F_x = m \cdot g \cdot \mu$

Translational Acceleration torque

$$M_{trans} = \frac{F_a \cdot p}{2 \cdot \pi \cdot 1000}$$

with feed force $F_a = m \cdot a$

If used vertically, the mass acceleration a must be added to the acceleration due to gravity g ($9.81\ m/s^2$).

Rotational acceleration torque

$$M_{rot} = \frac{J_{sp} \cdot L \cdot n_{max} \cdot a \cdot 2 \cdot \pi}{V_{max} \cdot 60 \cdot 1000}$$

Drive power

$$P = \frac{M_A \cdot n_{max}}{9550}$$

Definitions

M_A	[Nm]	required drive torque
M_{leer}	[Nm]	Torque, resulting from the various loads
M_{leer}	[Nm]	No load torque
M_{rot}	[Nm]	Rotational acceleration torque
M_{trans}	[Nm]	translational acceleration torque
F_x	[N]	Feed force
g	[m/s ²]	Acceleration due to gravity
v_{max}	[m/s]	maximum process speed
m	[kg]	The weight to be conveyed
a	[m/s ²]	Acceleration
p	[mm]	Spindle pitch
P	[kW]	Power
L	[mm]	Length
n_{max}	[rpm]	maximum speed
μ		coefficient of friction
J_{sp}	[kgm ² /m]	Inertial torque of inertia of the spindle per meter
F_a	[N]	Accelerating force

Mechanical specification

Linear unit	LES 4	LES 5	LES 6
Aluminium profile WxH (mm)	75 x 75	225 x 75	150 x 75
Guide weight (kg/m)	6.2	13.8	11.4
Moment of inertia I_x (cm ⁴)	126	299	212
Moment of inertia I_y (cm ⁴)	107	2362	707
Weight with spindle (kg/m)	7.6	15.2	12.8
Guide slides	1x WS 5-70 2x WS 5-70	2x WS 5-70 4x WS 5-70	
Slide weight (kg)	0.34 / 0.68	0.68 / 1.36	
Spindle pitch (mm)	2.5 / 4 / 5 / 10 / 20		
Max. permissible feed force (N)	2626 / 3450 / 3450 / 3150 / 1425		
Repeat accuracy (mm)	± 0.02		
Process path (mm)	L 1 - 150 / L 1 - 280		
Noise level (dBA)	< 85		
Storage temperature range (°C)	0 – 40		
Operating temperature range (°C)	0 – 60 (80)		
Relative air humidity (%)	< 90		

Combination examples LES ... with cable drag chain 9

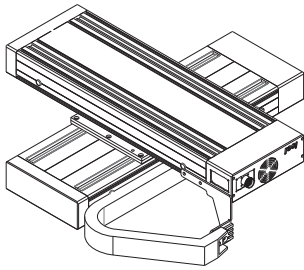

Crossbench

2 x LES 5
 PS 4 with VP 2
 Fixing cable drag chain 9
 Slide on slide assembly

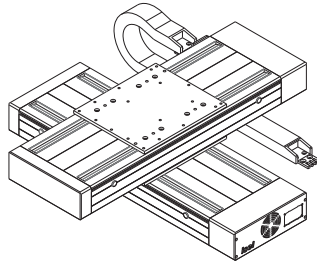

Crossbench

2 x LES 5
 PS 4 with VP 2
 Fixing cable drag chain 9
 Profile on slide assembly

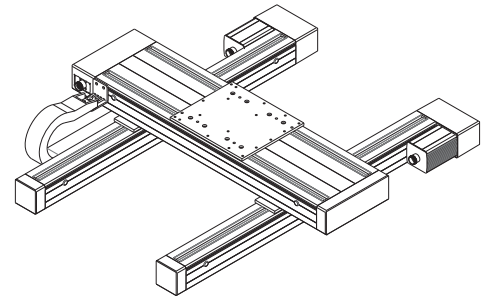

2-axis H-design

2 x LES 4, LES 5, 2 x PS 2, PS 4,
 Fixing cable drag chain 9
 Gantry mode

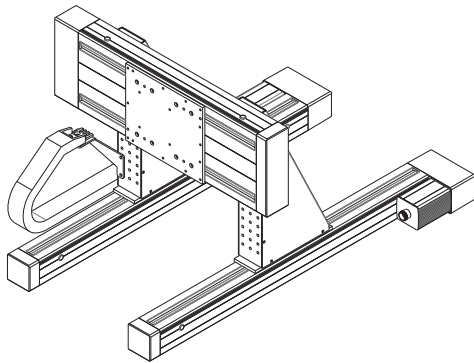

2-axis flatbed configuration

2 x LES 4, LES 5, 2 x PS 2
 2 x WV 2, PS 4, Fixing cable drag chain 9
 Gantry mode

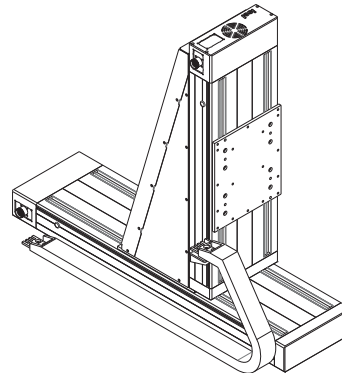

2-axis lifting configuration

2 x LES 5, 2 x PS 4, WV 6,
 Fixing cable drag chain 9

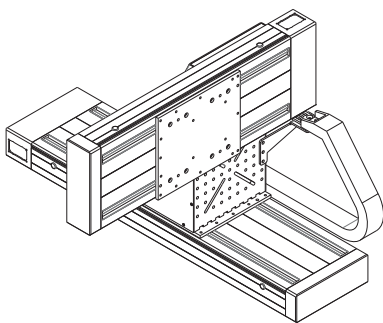

2-axis boom configuration

2 x LES 5
 2 x PS 4
 WV 3
 Fixing cable drag chain 9

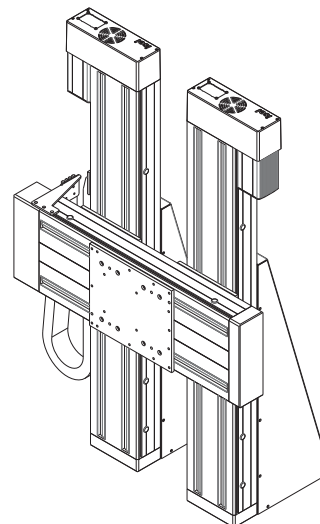

2-axis H-design

LES 5, 2 x LES 6, 2 x WV 7,
 2 x PS 12, PS 4,
 Fixing cable drag chain 9,
 Gantry mode

Combination examples LES ... with cable drag chain 9

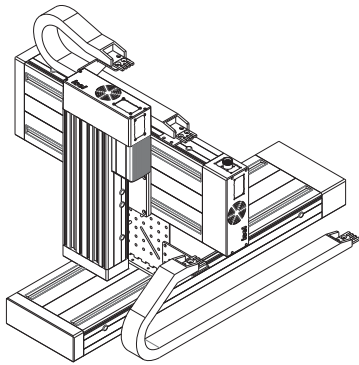

3-axis boom configuration

2 x LES 5, LES 6, WV 3, PS 4, PS 7, Fixing cable drag chain 9

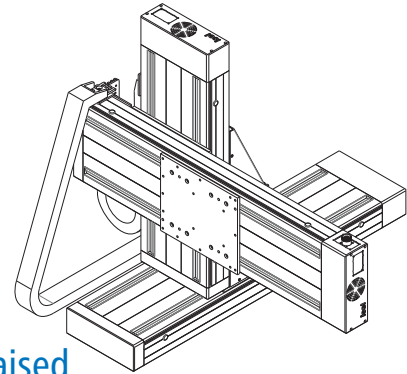

3-axis raised configuration

3 x LES 5, WV 3, 2 x PS 4, VP 2, Fixing cable drag chain 9

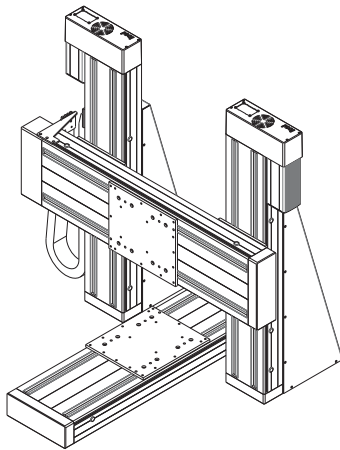

3-axis portal configuration

2 x LES 5, 2 x LES 6, 2 x WV 7, 2 x PS 4, 2 x PS 12, Gantry mode, Fixing cable drag chain 9

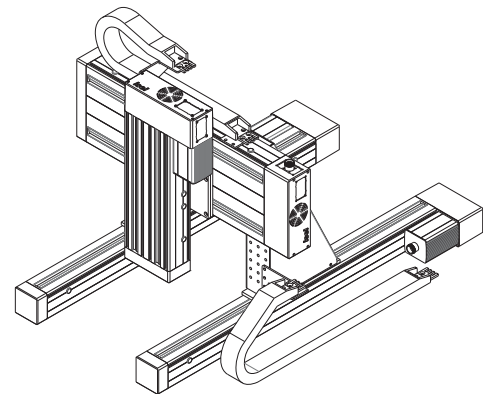

3-axis flatbed configuration

2 x LES 4, LES 5, LES 6, 2 x PS 2, 2 x WV 2, PS 4, PS 7, Fixing cable drag chain 9, Gantry mode

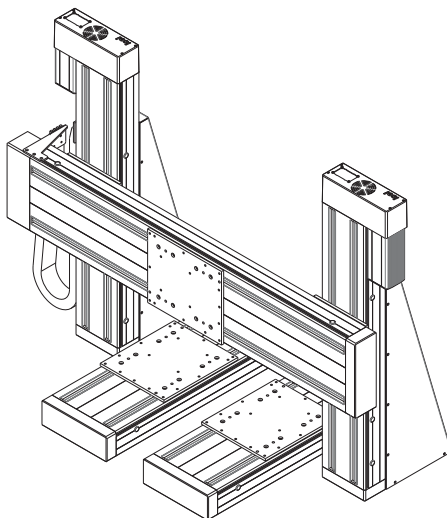

4-axis portal configuration

3 x LES 5, 2 x LES 6, 2 x WV 7, 3 x PS 4, 2 x PS 12, Fixing cable drag chain 9

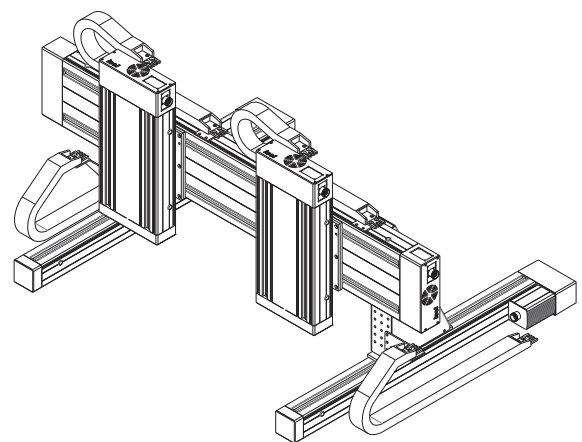

5-axis flatbed configuration

2 x LES 5 (Z-axis), LES 5 (2 spindle drives)
2 x LES 4, 2 x PS 2, 2 x WV 2,
2 x PS 4 with VP 2
Fixing cable drag chain 9

Motor modules

Ordering overview

LES 4/5/6 direct drives	Circular plug	Circular plug with brake	Single axis controller	Multiple axis controller
DC servomotor DC 100	396112 0060	-	MC 1-10	iCU-DC / iPU-DC
Stepper motor MS 200 HT - 2	396058 0060	396058 0260	IT 116 Flash	iMC-P / iMC-S8
EC servomotor EC 60S	396415 0060	396415 0260	MC 1-20	iCU-EC / iPU-EC
EC servomotor EC 60L 48V	396423 0060	396423 0260	MC 1-20	iCU-EC / iPU-EC
EC servomotor EC 60L 310V	396423 0070	396423 0270	MC 1-40	iCU-EC / iPU-EC
EC servomotor EC 86L	396466 0070	-	MC 1-40	Switching cabinet
EC servomotor EC 86S	396444 0070	-	MC 1-40	Switching cabinet
Stepper motor MS 300 HT - 2	396082 0060	396082 0260	iMC-S8	iMC-S8
Stepper motor MS 600 HT	396085 0060	-	iMC-S8	iMC-S8
Stepper motor MS 900 HT	396088 0060	-	iMC-S8	iMC-S8
LES 5 integrated	Circular plug	Circular plug with brake	Single axis controller	Multiple axis controller
Stepper motor MS 200 HT - 2	396058 1060	396058 1260	IT 116 Flash	iMC-P / iMC-S8
DC servomotor DC 100	396112 1060	-	MC 1-10	iCU-DC / iPU-DC
EC servomotor EC 60S	396415 1060	396415 1260	MC 1-20	iCU-EC / iPU-EC
EC servomotor EC 60L 48V	396423 1060	-	MC 1-20	iCU-EC / iPU-EC
EC servomotor EC 60L 310V	396423 1070	396423 1270	MC 1-40	Switching cabinet
LES 4/LES 6 side mounting	Circular plug	Circular plug with brake	Single axis controller	Multiple axis controller
Stepper motor MS 200 HT - 2	396058 2060	396058 2260	IT 116 Flash	iMC-P
DC servomotor DC 100	396112 2060	-	MC 1-10	iCU-DC
EC servomotor EC 60S	396415 2060	396415 2260	MC 1-20	iCU-EC
EC servomotor EC 60L 48V	396423 2060	-	MC 1-20	iCU-EC
EC servomotor EC 60L 310V	396423 2070	396423 2270	MC 1-40	iCU-EC

Motor modules

Dimensioned drawing

Motor module 1

Part no.	Motor module	Length L
396112 0060	DC 100	185 mm
396058 0360	MS 200 HT-2 with brake	165 mm
396058 0060	MS 200 HT-2 without brake	105 mm

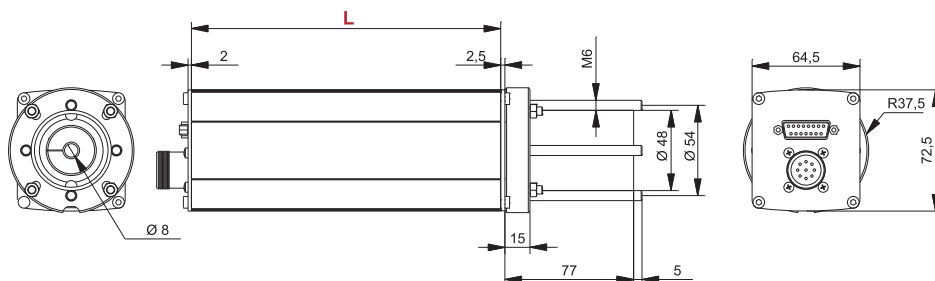

Dimensioned drawing

EC 60

Part no.	Motor module	Length L
396415 0260	EC 60S with brake	99 mm
396415 0060	EC 60S without brake	99 mm
396423 0060	EC 60L 48V	120 mm
396423 0070	EC 60L 310V	120 mm

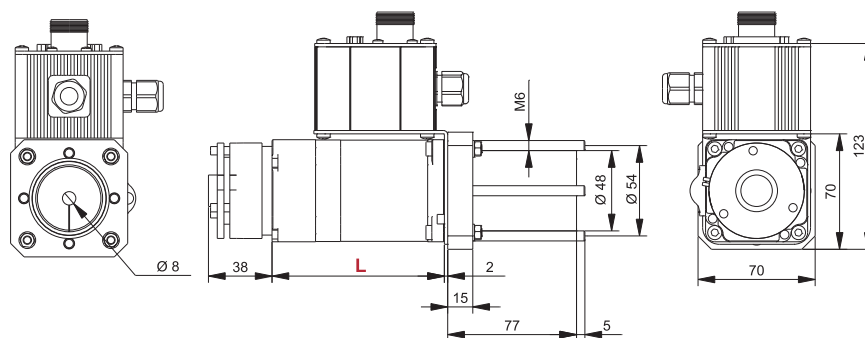

Dimensioned drawing

Motor module 2

Part no.	Motor module	Length L
396466 0070	EC 86L	151 mm
396444 0070	EC 86S	126 mm
396085 0060	MS 600HT	96 mm
396088 0060	MS 900 HT	126 mm

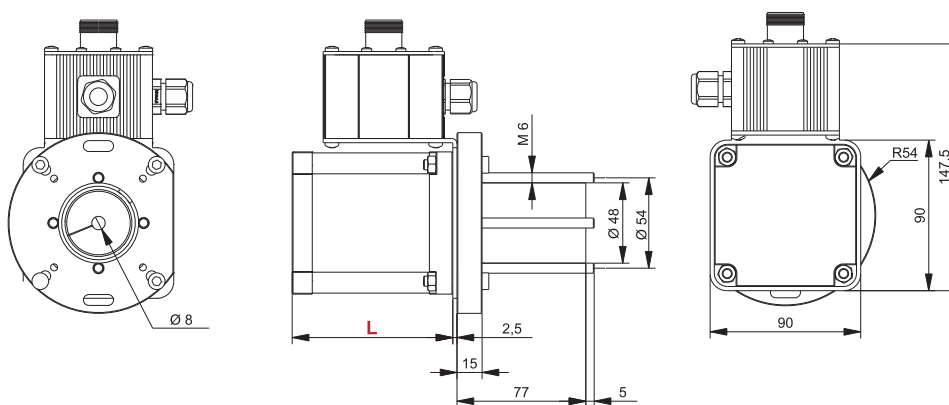

Clutch housing

Drive element accessories

Connection options

Direct drive preparation

Connecting options <i>Direct drive</i>	LES 4	LES 6	LES 5	Angular gear fixing 0°	Angular gear fixing 90°
MS 200 HT-2 DC 100 EC 60	Connection via coupling casing 1 <i>short sleeve</i> with adequate shaft coupling				Coupling casing 1 <i>long sleeve</i>
MS 600 HT MS 900 HT EC 86	Connection via coupling casing 2 <i>short sleeve</i> with adequate shaft coupling				Coupling casing 2 <i>long sleeve</i>
Angular gear fixing 0°	split coupling casing <i>short sleeve</i> with adequate shaft coupling			Connection via transmission shaft set	
Angular gear fixing 90°	split coupling casing <i>short sleeve</i> with adequate shaft coupling				

Ordering overview

Clutch housing

Clutch housing 1

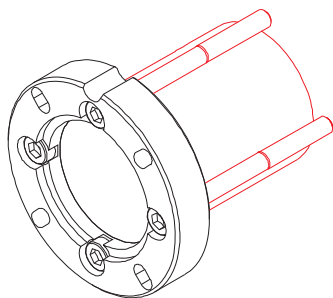

short sleeve
Part no.: 218 100 0001

long sleeve
Part no.: 218 100 0002

Clutch housing 2

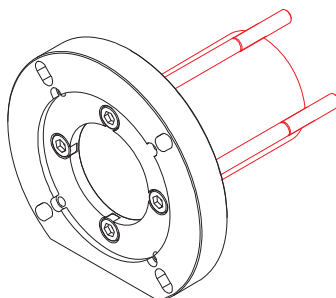

short sleeve
Part no.: 218 100 1001

long sleeve
Part no.: 218 100 1002

Split clutch housing

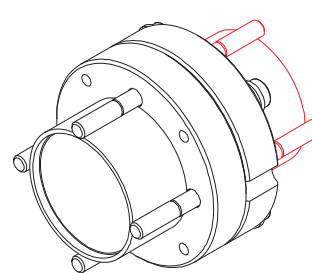

short sleeve
Part no.: 218 100 2001

long sleeve
Part no.: 218 100 2002

Clutches

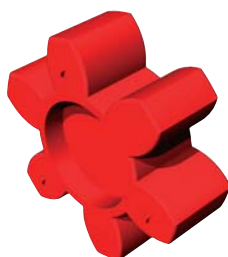
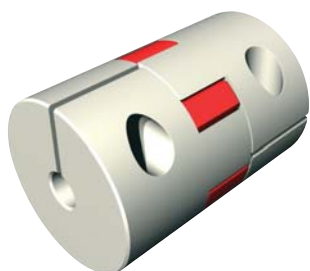

coupling	Item no.:	d ₁	d ₂
20/30	218 001 5060	5,0	6,0
	218 001 9999	from 4 to 7 mm	
30/40	218 002 6380	6,35	8,0
	218 002 8080	8,0	8,0
	218 002 9999	from 6 to 13 mm	
40/60	218 003 9580	9,52	8,0
	218 003 9999	from 8 to 18 mm	

Clutch housing

Drive element accessories

Dimensioned drawing

Coupling casing 1

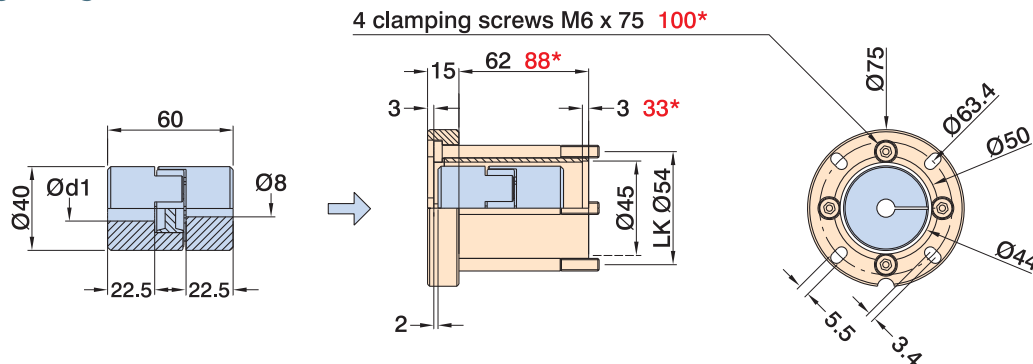

**) Measures refer to the dimensions with long sleeves*
d1 = engine shaft diameter 6.35/8/9 mm
Suitable shaft coupling WK 40/60 on page 2-68 (not included in scope of delivery)

Dimensioned drawing

Coupling casing 2

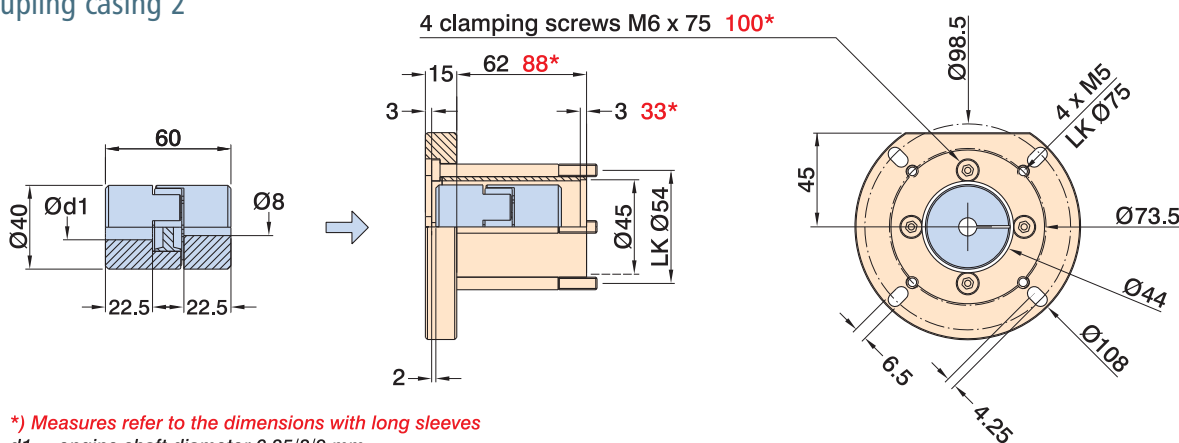

**) Measures refer to the dimensions with long sleeves*
d1 = engine shaft diameter 6.35/8/9 mm
Suitable shaft coupling WK 40/60 on page 2-68 (not included in scope of delivery)

Dimensioned drawing

Split coupling casing

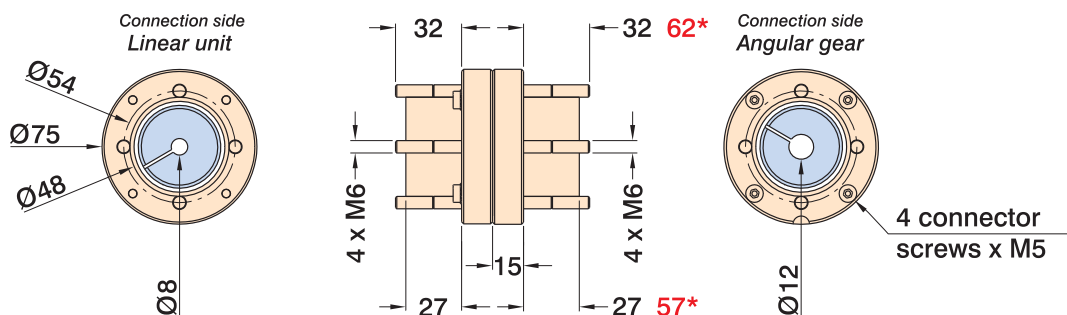

**) Measures refer to the dimensions with long sleeves*
Suitable shaft coupling WK 40/60 on page 2-68 (not included in scope of delivery)

Motor pin assignments

Pin assignment for stepper motors

Motor connection

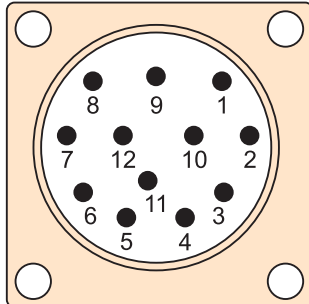

View of pin insert at the insertion side

M23 12-pin Pin	
1	Motor phase 1A
2	Motor phase 1B
3	Motor phase 2A
4	Motor phase 2B
5	+24V switch
6	+24V brake
7	GND switch
8	GND brake
9	Limit switch 1
10	Limit switch 2
11	---
12	---
Housing - cable shield	

Motor connection

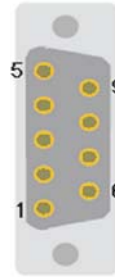

View of pin insert on the socket side

Sub-D 9-pin Pin	
1	Motor phase 1A
2	Motor phase 1B
3	Motor phase 2A
4	Motor phase 2B
5	+24V switch
6	+24V brake
7	Limit switch 2
8	GND brake
9	Limit switch 1
Housing - cable shield	

Pin assignment for DC servo motors with brushes (BDC)

Motor connection

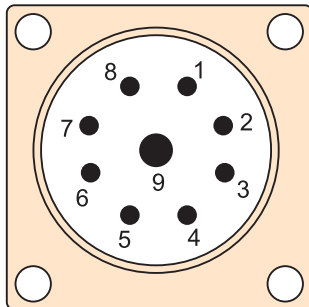

View of pin insert on the socket side

M23 9-pol. (8+1) pin	
1	Motor phase 1 (V+)
2	Motor phase 1 (V-)
3	Motor phase 1 (V+)*
4	Motor phase 1 (V-)*
5	+24V brake
6	GND brake
7	---
8	---
9	Earthing lead
Housing - cable shield	

* Part motor phase connection also by means of 2 wires.

Encoder connection

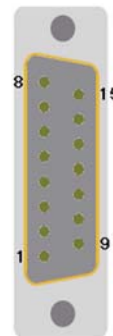

View of pin insert on the socket side

Sub-D 15-pin Pin	
1	---
2	+5V encoder
3	Encoder track/Z
4	Encoder track/B
5	Encoder track/A
6	+24V switch
7	Limit switch 1
8	GND switch
9	---
10	GND encoder
11	Encoder track Z
12	Encoder track B
13	Encoder track A
14	Reference switch
15	Limit switch 2
Housing - cable shield	

Pin assignment for brushless EC servo motors (BLDC) 48V

Motor connection

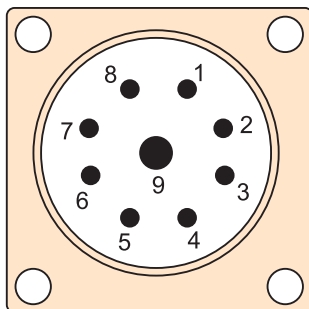

View of pin insert on the socket side

M23 9-pol. (8+1) pin	
1	Motor phase U
2	Motor phase V
3	Motor phase W
4	---
5	+24V brake
6	GND brake
7	---
8	---
9	Earthing lead
Housing - cable shield	

Encoder connection

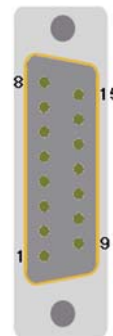

View of pin insert on the socket side

Sub-D 15-pin Pin	
1	Hall signal A
2	+5V encoder/Hall
3	Encoder track/Z
4	Encoder track/B
5	Encoder track/A
6	+24V switch
7	Limit switch 1
8	GND switch
9	Hall signal B
10	GND encoder
11	Encoder track Z
12	Encoder track B
13	Encoder track A
14	Hall signal C
15	Limit switch 2
Housing - cable shield	

Motor leads

Pin assignment for brushless EC servomotors (BLDC) 310V

Motor connection

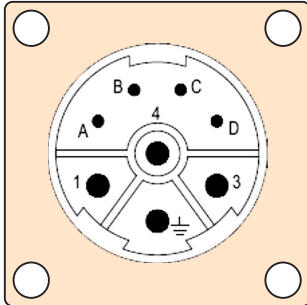

View of pin insert at the insertion side

M23 8-pol. (4+3+1) pin

1	Motor phase U
PE	Earthing lead
3	Motor phase W
4	Motor phase V
A	+24V brake
B	GND brake
C	Temp +
D	Temp -
Housing - cable shield	

Encoder connection

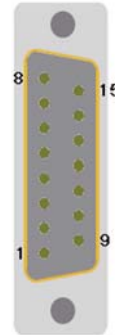

View of pin insert at the insertion side

Sub-D 15-pin Pin

1	Hall signal A
2	+5V encoder/Hall
3	Encoder track/Z
4	Encoder track/B
5	Encoder track/A
6	+24V switch
7	Limit switch 2
8	GND switch
9	Hall signal B
10	GND encoder
11	Encoder track Z
12	Encoder track B
13	Encoder track A
14	Hall signal C
15	Limit switch 2
Housing - cable shield	

Overview of motor leads for stepper, DC servo and EC motors*

Part number	Description
392750 0500	5-metre stepper motor lead M23 12-pin plug - socket 1:1
392755 0500	5-metre stepper motor lead D-sub 9-pin plug - M23 12-pin socket
392781 0500	5-metre stepper motor lead D-sub 9-pin plug - socket 1:1
392759 0500	5-metre DC/EC servo motor lead M23 9-pin (8 + PE) plug - socket 1:1
392760 0500	5-metre DC/EC servo motor lead M23 9-pin (8+PE) socket - wire end ferrules
392740 0500	5-metre encoder lead D-sub 15-pin plug - socket 1:1
392325 0500	5-metre encoder lead M23 17-pin socket - D-sub 15-pin plug
392305 0500	3-metre EC/AC servo motor lead M23 310V (4+3+PE) socket - wire end ferrules
392307 0500	5-metre EC servo motor lead M23 (4+3+PE) plug - socket 1:1

All listed motor and encoder leads are fit for use with tow chains.

* Different lengths available on request!

Installation kit with angular transmission

Drive element accessories

Installation alternatives

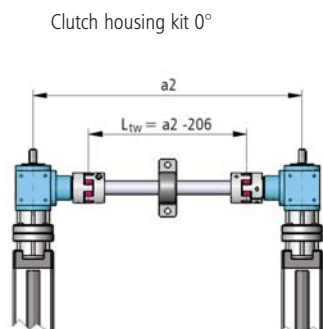
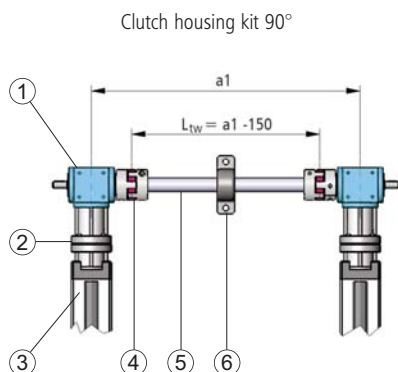

- ① Angular gear
- ② Split coupling casing with shaft coupling WK 40/60
- ③ LES 4, LES 6 or LES 5 (preparation for direct drive)
- ④ Coupling for transmission shaft $\varnothing 25$
- ⑤ Transmission shaft $\varnothing 25$
- ⑥ Pedestal bearing - recommendable from : transmission shaft length of 1,500 mm up

Dimensioned drawing

Angular transmission

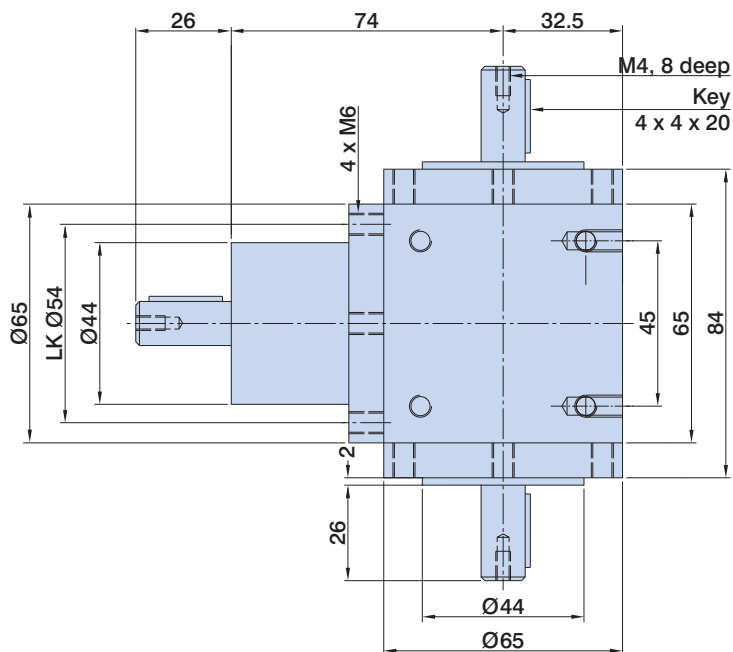
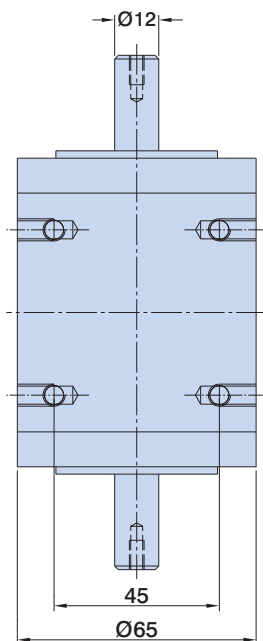

Ordering overview

Installation kit with angular transmission

for H-design on LES 4/LES 6/LES 5,
0° mounting
Scope of delivery: 2 x ①, 2 x ②, 2 x ④
Part no.: **216150 0001**

for H-design on LES 4/LES 6/LES 5,
90° mounting
Scope of delivery: 2 x ①, 2 x ②, 2 x ④
Part no.: **216150 0002**

Transmission shaft

Hollow shaft $\varnothing 25$ mm \times 4 mm, blank
1000 mm
Part no.: **219001 0125**

Hollow shaft $\varnothing 25$ mm \times 4 mm, blank
2000 mm
Part no.: **219001 0225**

Coupling/stationary bearing

Coupling for transmission shaft
12 to 25 mm adaptor, VE 2 units
Part no.: **218050 0002**

Stationary bearing for transmission shaft
VE 1 unit
Part no.: **896202 5562**

For matching direct drive modules LES 4/5/6 see table on page **B-56**

Installation kit with angular transmission

Drive element accessories

Dimensioned drawing and technical specification

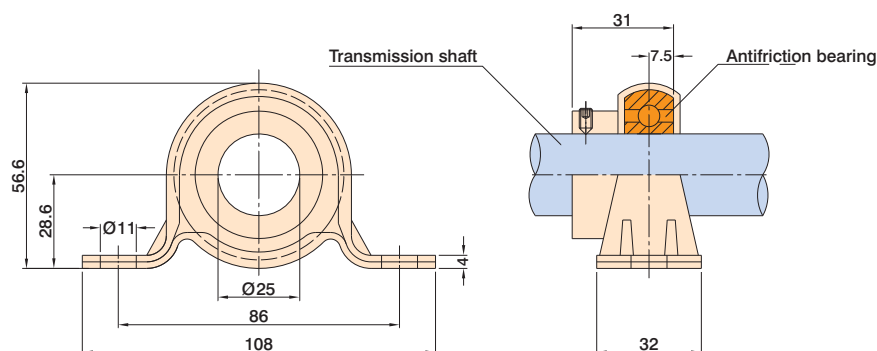

Pedestal bearing- to avoid vibrations/to support the transmission shaft (recommndable from a transmission shaft length of 1,500 mm up)	
Transmissible torque	18 Nm
Weight of coupling	0.3 kg
Weight of shaft	0.540 kg/m
Moment of inertia of both couplings	$2.68 \cdot 10^{-4} \text{ kgm}^2$
Moment of inertia of shaft	$8.171 \cdot 10^{-6} \text{ kgm}^2 / 100 \text{ mm}$

Dimensioned drawing - coupling

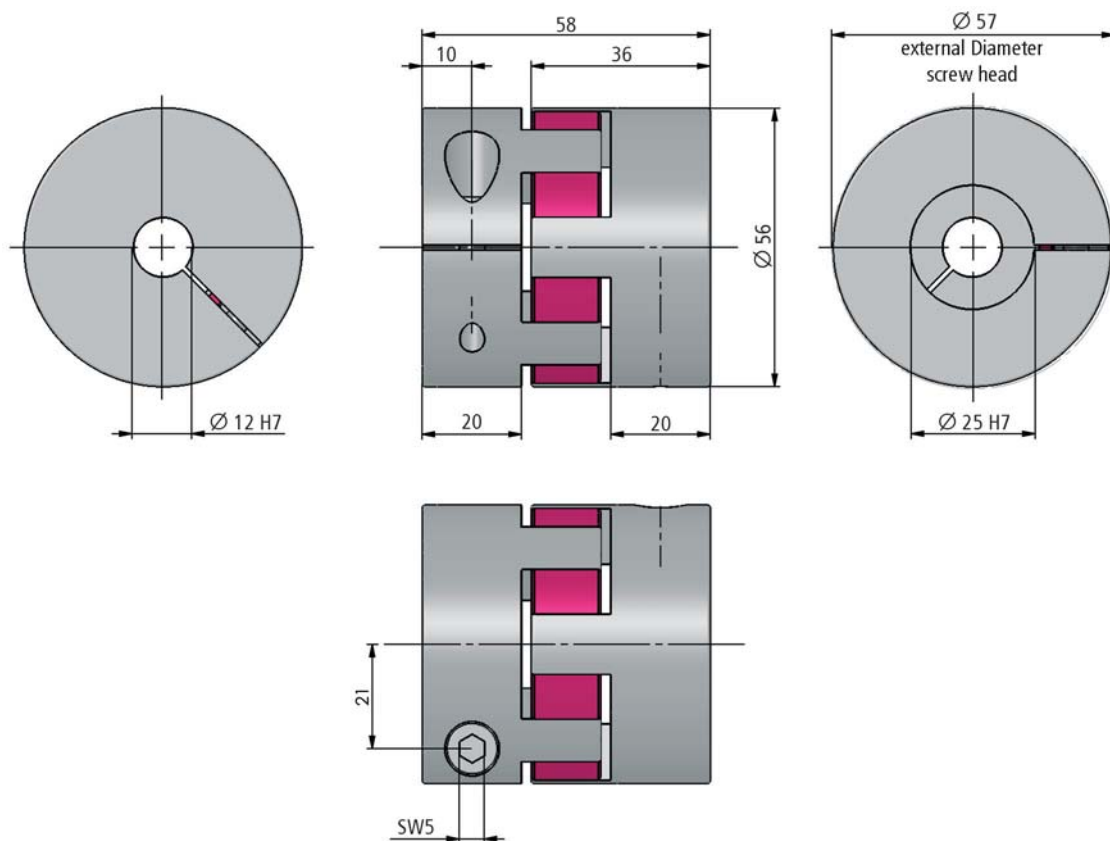

Part no. **218050 0002**

Slide/crossbench plates

Connectors

Hole diagram, slide plate PS 1

L 125 x W 70 x H 7.7 mm

Mounting on:
LES 4 with 1 x WS 5/70

Part no.: **277001**

Connecting cross
2 x LES 4

Part no.: **277007**

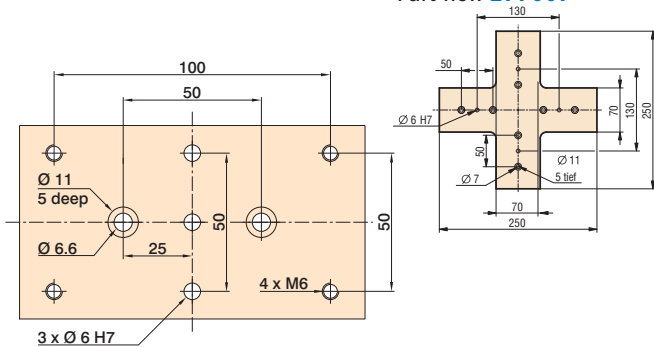

Hole diagram, slide plate PS 2

L 255 x W 70 x H 7.7 mm

Mounting on:
LES 4 with 2 x WS 5/70

Fixing option for:
Angle bracket WV 2 / WV 5

Part no.: **277002**

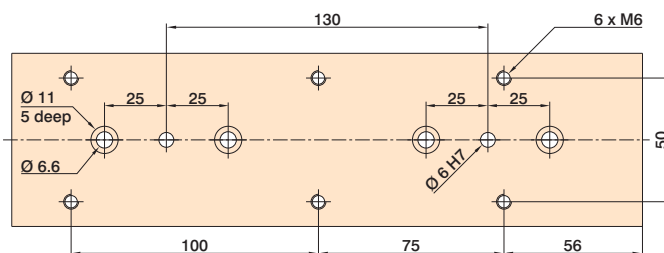

Hole diagram, slide plate PS 3

L 220 x W 125 x H 7.5 mm

Mounting on:
LES 5 with 2 x WS 5/70

Part no.: **277003**

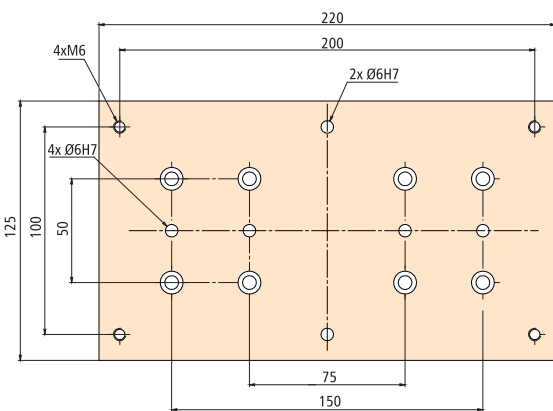

Hole diagram, slide plate PS 4

L 225 x W 220 x H 7.5 mm

Mounting on: LES 5 with 4 x WS 5/70
Mounting on crossbench: LES 5 with LES 5 (in conjunction with VP 2)
Fixing option for: Angle bracket WV 3 / WV 6

Part no.: **277004**

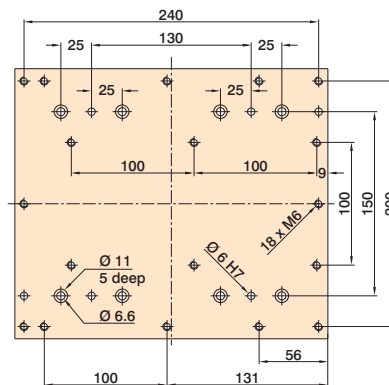

Hole diagram, slide plate PS 6

L 220 x W 125 x H 7.5 mm

Mounting on: LES 4 with 2 x WS 5/70
Mounting on crossbench: LES 4 with LES 5 (in conjunction with PS 3).
Fixing option for: LES 4/LES 5

Part no.: **277011**

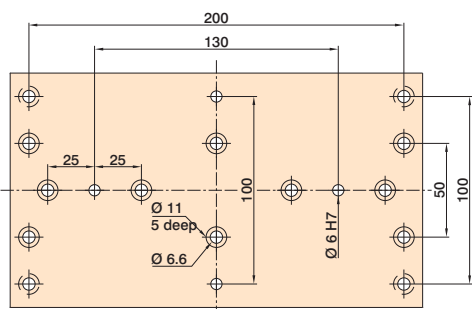

Hole diagram, slide plate PS 7

L 255 x W 220 x H 7.5 mm

Mounting on: LES 6 with 4 x WS 5/70
Mounting on crossbench: LES 6 with LES 5 (in conjunction with PS 4)

Part no.: **277016**

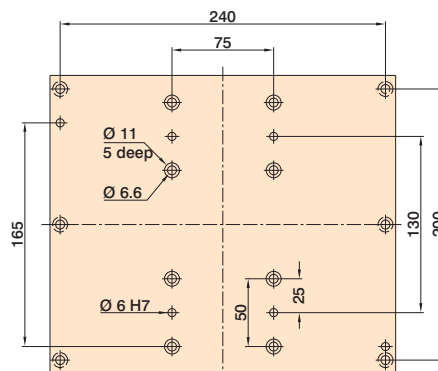

Slide/crossbench plates

Connectors

Hole diagram, slide plate PS 8

L 125 × W 145 × H 7.7 mm

Mounting on:

LES 6 with 2 × WS 5/70 **Part no.: 277017**

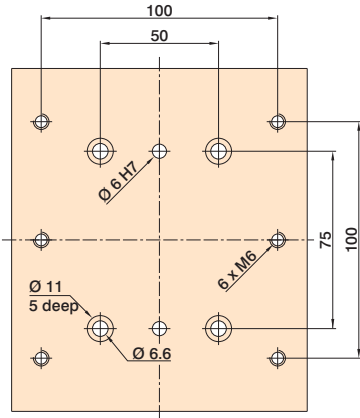

Hole diagram, slide plate PS 9

L 250 × W 145 × H 7.5 mm

Mounting on: LES 6 with 4 × WS 5/70

Fixing option for: Angle bracket WV 7

Part no.: 277018

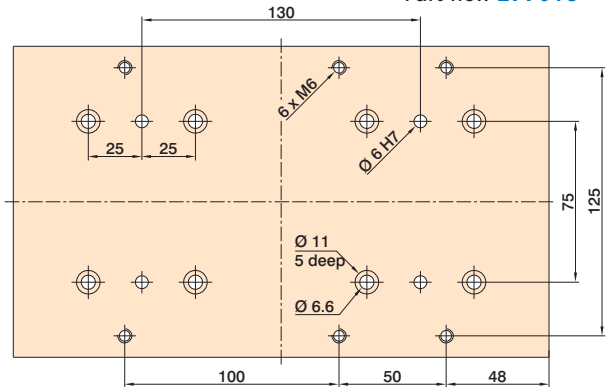

Hole diagram, slide plate PS 10

L 210 × W 215 × H 7.5 mm

Mounting on: LES 6 with 4 × WS 5/70

Mounting on crossbench: LES 6 with LES 6 (in conjunction with PS 11)

Part no.: 277019

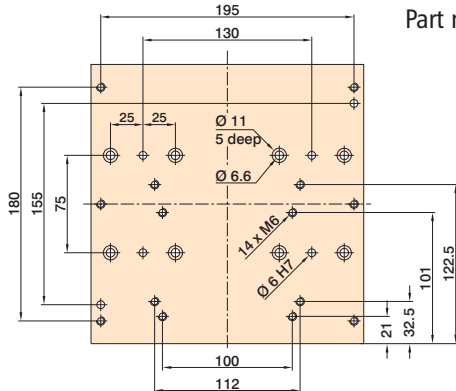

Hole diagram, slide plate PS 11

L 210 × W 215 × H 7.5 mm

Mounting on: LES 6 with 4 × WS 5/70

Mounting on crossbench: LES6 with LES4 (in conjunction with PS10) Fixing option for: LES 6

Part no.: 277020

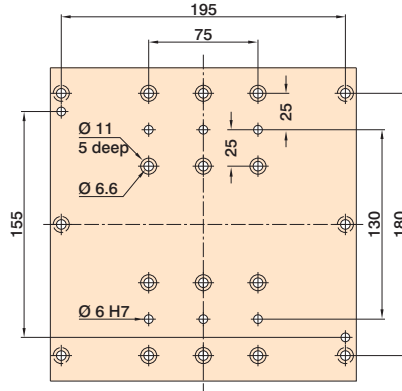

Hole diagram, slide plate PS 12

L 220 × W 180 × H 7.5 mm

Mounting on: LES 6 with 4 × WS 5/70

Fixing option for: LES 5 **Part no.: 277021**

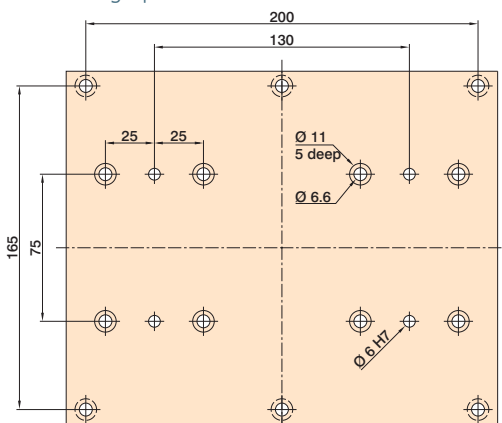

Hole diagram, connection plate VP 2

L 255 × W 220 × H 7.5 mm

Mounting on: LES 5 with 4 × WS 5/70

Fixing option for: LES 5

Part no.: 277006

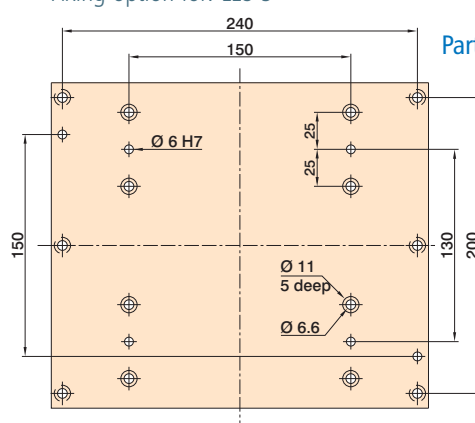

Slide/crossbench plates

Connectors

Hole diagram, slide plate set for crossbench LES 4

L 100 x W 100 x H 8 mm

Mounting on: LES 4

Fixing option for: LES 4

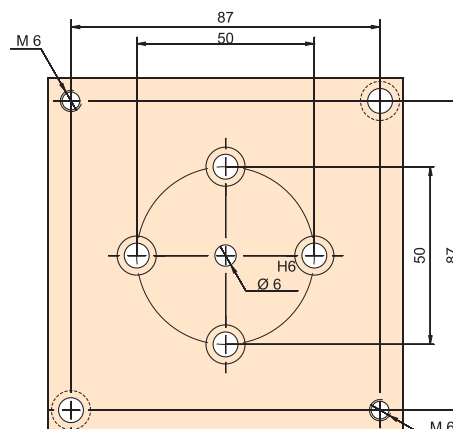
Part no.: **277008**

Crossbench connection plates 1



Crossbench connection plates 1

 $2 \times L 255 \times W 220 \times H 8 \text{ mm}$

one set from PS 4 and VP 2,
for right-angled connection
two linear guides LES 5

Part no.: **277010**

Crossbench connection plates 2



Crossbench connection plates 2

 $2 \times L 220 \times W 125 \times H 8 \text{ mm}$

one set from PS 3 and PS 6,
for right-angled connection
one linear guide LES 5 with one
linear guide LES 4

Part no.: **277012**

Additional combination examples



Crossbench LES 5 and LES 6
PS 4 and PS 7



Crossbench $2 \times$ LES 6
PS 10 and PS 11



Crossbench LES 4 and LES 6
PS 11 and PS 10

T-slot slide plates

Connectors

Hole pattern T-slot plate PT 25 × 250 for LES 4

L 100 x W 75 x H 20 mm

Mounting on: LES 4 with 1 x WS 5/70

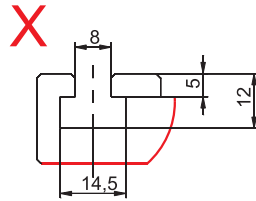
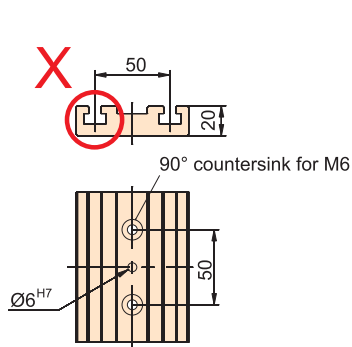
Part no.: **277030 0001**

L 200 x W 75 x H 20 mm

Mounting on: LES 4 with 2 x WS 5/70

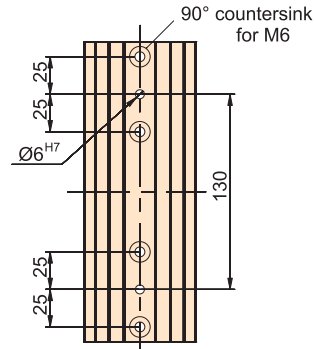
Part no.: **277030 0002**

Hole pattern T-slot plate PT 25 × 250 for LES 6

L 100 x W 125 x H 20 mm

Mounting on: LES 6 with 2 x WS 5/70

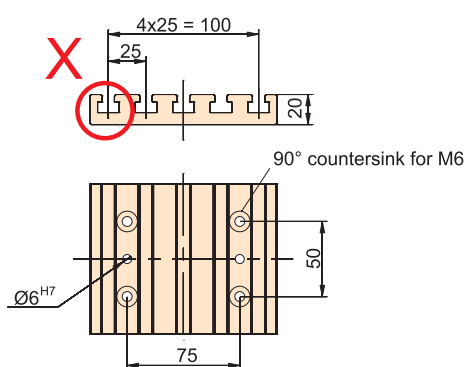
Part no.: **277030 0003**

L 200 x W 125 x H 20 mm

Mounting on: LES 6 with 4 x WS 5/70

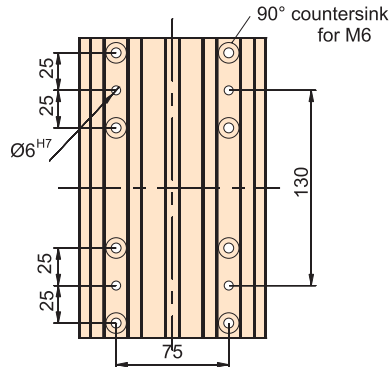
Part no.: **277030 0004**

Hole pattern T-slot plate PT 25 × 250 for LES 5

L 100 x W 250 x H 20 mm

Mounting on: LES 5 with 2 x WS 5/70

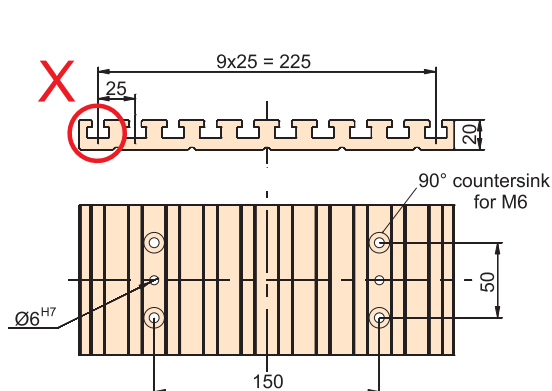
Part no.: **277030 0005**

L 200 x W 250 x H 20 mm

Mounting on: LES 5 with 4 x WS 5/70

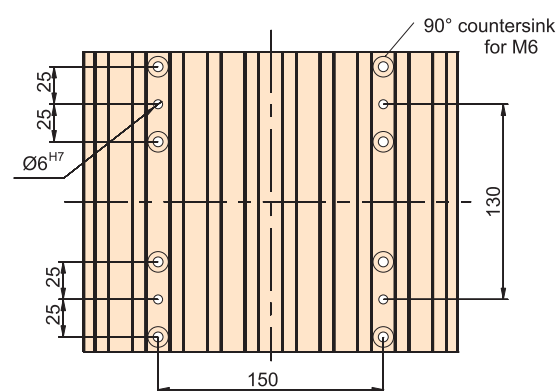
Part no.: **277030 0006**

Angle brackets

Connectors

Angle bracket with clamping surfaces milled flat

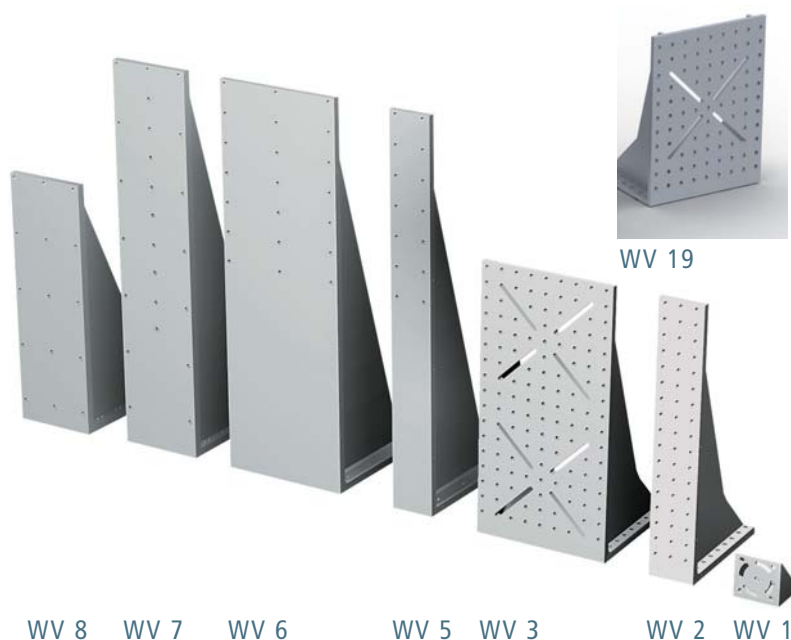

matching cover plates

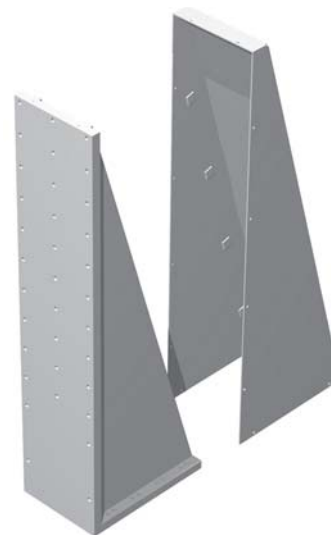

Angle bracket WV 1

- blank
- Aluminium casting (0.2 kg)
- L71 x W75 x H71

Part no.: **209110 0010**

Angle bracket WV 2

- blank
- Aluminium casting (2.6 kg)
- L221 x W75 x H446

Part no.: **209110 0022**

Angle bracket WV 3

- blank
- Aluminium casting (5.8 kg)
- L221 x W221 x H446

Part no.: **209110 0032**

Angle bracket WV 5

- blank
- Aluminium welded (5.26 kg)
- L220 x W75 x H670

Part no.: **209 110 0050**

Angle bracket WV 6

- blank
- Aluminium welded (13.3 kg)
- L220 x W220 x H670

Part no.: **209110 0060**

Angle bracket WV 7

- blank
- Aluminium welded (10.8 kg)
- L220 x W145 x H670

Part no.: **209110 0070**

Angle bracket WV 8

- blank
- Aluminium welded (7.4 kg)
- L222 x W145 x H446

Part no.: **209110 0080**

Angle bracket WV 19

- blank
- Aluminium welded (2.5 kg)
- L150 x W221 x H300

Part no.: **209110 0190**

Cover plate for WV 2

- naturally anodised
- Aluminium sheet (0.8 kg)

Part no.: **209110 0021**

Cover plate for WV 3

- naturally anodised
- Aluminium sheet (1.15 kg)

Part no.: **209110 0031**

Cover plate for WV 5

- naturally anodised
- Aluminium sheet (1.20 kg)

Part no.: **209 110 0051**

Cover plate for WV 6

- naturally anodised
- Aluminium sheet (1.8 kg)

Part no.: **209110 0061**

Cover plate for WV 7

- naturally anodised
- Aluminium sheet (1.5 kg)

Part no.: **209110 0071**

Cover plate for WV 8

- naturally anodised
- Aluminium sheet (1 kg)

Part no.: **209110 0081**

Angle brackets

Connectors

Hole diagram

Angle bracket WV 1

L 71 x W 75 x H 71 mm

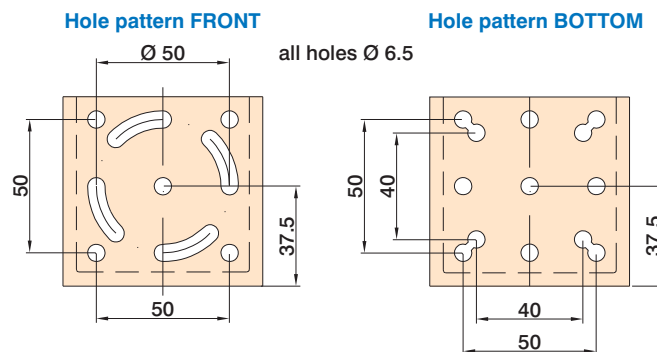

Hole diagram

Angle bracket WV 2

L 221 x W 75 x H 446 mm

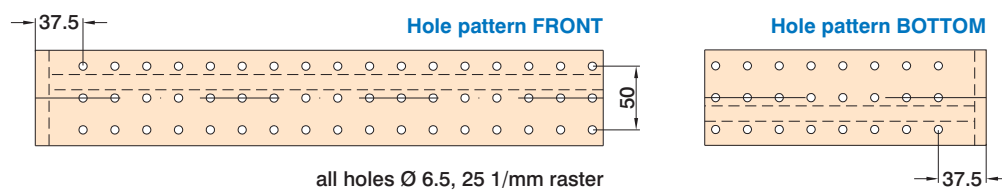

Hole diagram

Angle bracket WV 3

L 221 x W 221 x H 446 mm

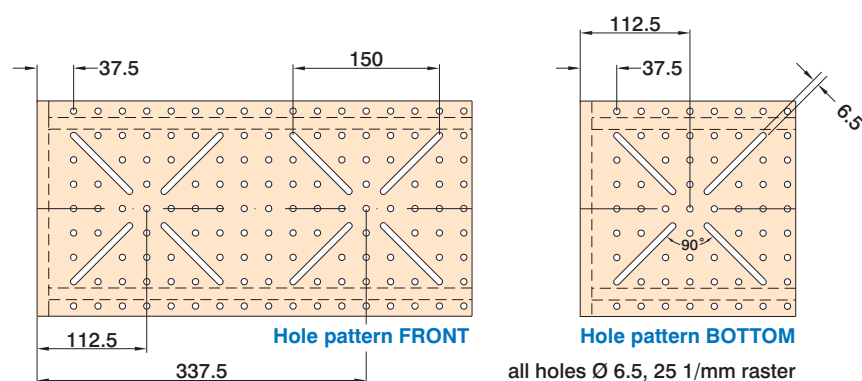

Hole diagram

Angle bracket WV 5

L 220 x W 75 x H 670 mm

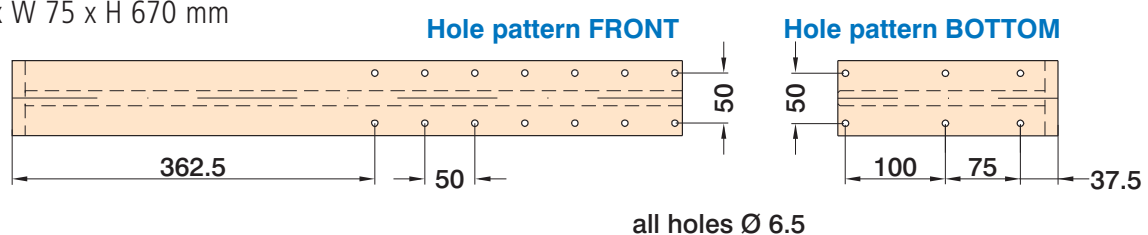

Angle brackets

Connectors

Hole diagram

Angle bracket WV 6

L 220 x W 220 x H 670 mm

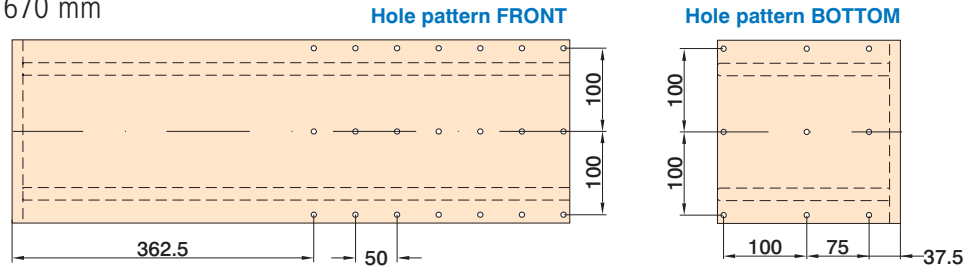

Hole diagram

Angle bracket WV 7

L 220 x W 145 x H 670 mm

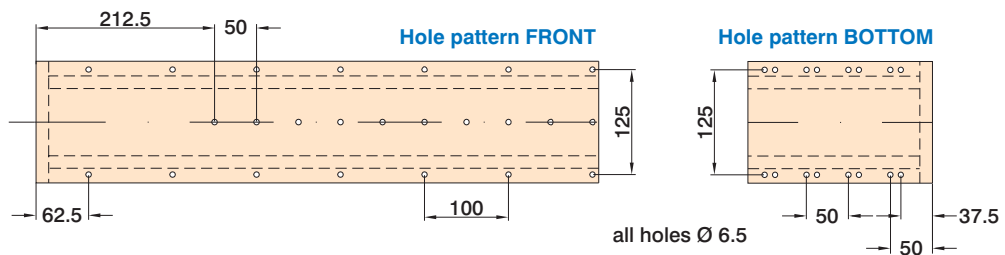

Hole diagram

Angle bracket WV 8

L 222 x W 145 x H 446 mm

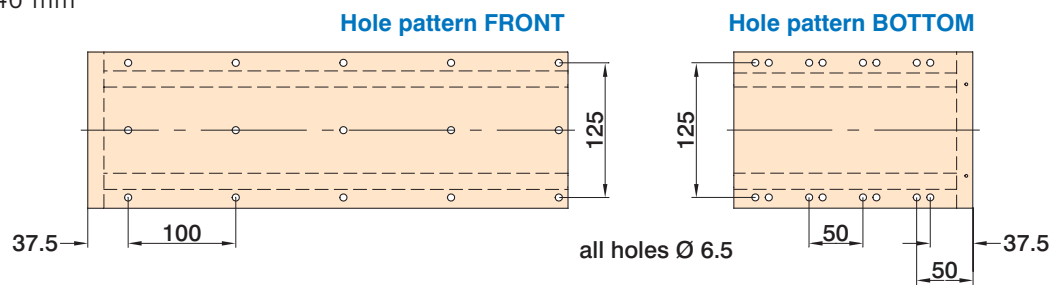

Hole diagram

Angle bracket WV 19

L 150 x W 221 x H 300 mm

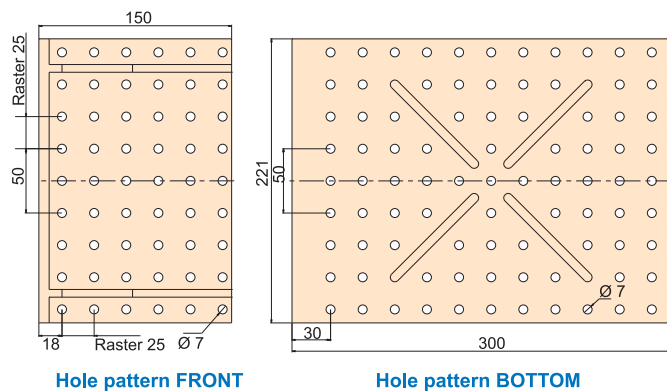

Accessories

Energy guidance chain



Dimensioned drawing
Energy guidance chain

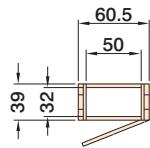

Energy guide chain 3

- VE 1 unit at 1 m
- Part no.: **219204 1000**

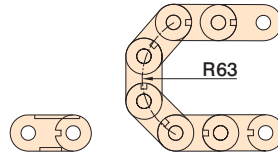

Connectors for energy chain 3

- with strain relief
- VE 1 kit
- Part no.: **219205 0002**

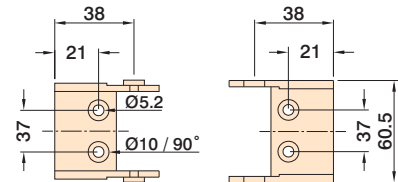

Tapped strips/sliding nuts

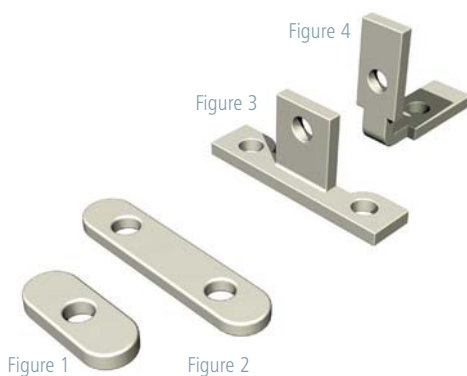

Tapped strips M6 (no figure)

- Galvanised
- Ra 50 mm
- 3 x VE 1 m piece
- Part no.: **209011**

Sliding nut 2 x M6 (Figure 2)

- Galvanised
- VE 50 pieces
- Part no.: **209002 0004**

Special angle sliding nut 3 x M6 (Figure 3)

- Galvanised
- VE 25 pieces
- Part no.: **209022 0003**

Sliding nut M6 (Figure 1)

- Galvanised
- VE 100 pieces
- Part no.: **209001 0005**

Angle sliding nut 2 x M6 (Figure 4)

- Galvanised
- VE 25 pieces
- Part no.: **209021 0003**

Sliding nut M5 (no figure)

- Galvanised
- VE 20 pieces
- Part no.: **209006 0001**

Attachment kits



Gas strut attachment kit

- Hub 220 mm
- Nominal length 490 mm
- Part no.: **216450 0001**

Gas strut attachment kit

- Stroke 300 mm
- Nominal length 690 mm
- Part no.: **216451 0001**

Limit switch attachment kit for LES 4

- for external limit switches
- Part no.: **216460 0001**

Limit switch attachment kit LES 6

- for external limit switches
- Part no.: **216460 0003**

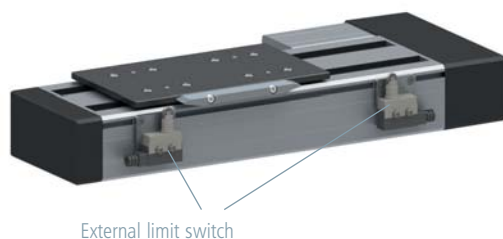

Limit switch attachment kit LES 5

- for external limit switches
- Part no.: **216460 0002**

Mounting set for sealing air

- for LES4 - LES6
- Part no.: **216460 0006**

Linear unit with linear motor

iLD 50-6



Features

- Robust design in industrial quality
- Pinpoint positioning accuracy
- Wear-free design with no mechanical connecting links
- high dynamic acceleration up to 30 m/s²
- Multi-motor operation with multiple, separately moveable slides
- Extendable to 15 m travel

Options:

- Complete linear unit (see Order Information Table)
- Energy guide chain + guide plate to required length
- Brake
- Control package Metronix ARS 2310 (3-phase, 6 kVA, incl. configuration software)
- diverse Control packages (1- and 3-phase, up to 6 kVA)
- Drive controller ISEL iMD 40
- CAN CPC 12 positioning module
- Cable set iLD 50-6 for ISEL iMD 40

General

Linear units with linear motors are advantageous in precisely those areas where linear units with typical spindle drives are limited - they achieve high values of acceleration, offer pinpoint positioning and operate practically wear-free due to the absence of mechanical linkages.

Linear motors are increasingly used in linear technology machine tool applications, positioning systems and handling systems. Linear units with profile guides are particularly suitable for use in both machine tools and positioning systems.

isel iLD series linear units are constructed from rigid aluminium profiles. Guides consist of proven guide rails and recirculating ball shaft slots. A magnetic length-measuring system is also included. In this regard, isel linear motor units have the advantage of greater acceleration and higher traverse velocity. Iron-core linear motors can produce very high forces. An integrated brake is offered as an option, to allow the iLD to also be used in the vertical mode. The "made by isel" concept stands for optimum price/performance-ratio. This in turn means very short amortisation periods for customers.

Ordering data

Part number	L	L1
237110 0069	691	181
237110 0089	892	382
237110 0109	1094	584
237110 0129	1296	786
237110 0149	1497	987
237110 0169	1699	1189
237110 0190	1900	1390
237110 0210	2102	1592
237110 0230	2304	1794
237110 0250	2505	1995
237110 0270	2707	2197
237110 0290	2908	2398
237110 0311	3110	2600
237110 0331	3312	2802
237110 0351	3513	3003

Linear unit

with linear motor

iLD 50-6

Technical specification

General	
Areas of application	Positioning axes for the semiconductor industry and for general industrial applications, CNC machine axis
Processing speed (m/s)	to 4.5
Acceleration (m/s)	to 30
Repeatability (mm)	< 0.01
Process path (mm)	181 to 3003, optionally extendible to 15000
Drive electronics	Servo amplifier, communication via CAN bus or analogue input (+/- 10 V)
Maintenance	Maintenance-free, rapid component replacement (MTTR approx. 2 hours)
Mechanics	
Profile	Bend-proof hollow chamber profile (isel ILF 6), straightness of 0.1 mm per 1 m length, Bending max. 0.2 mm per 1 m length under 50 kg load, max. load 100 kg
Guides	Profile rail guide Series 15 to DIN EN 120/20
Mechanical brake (optional)	Profile guide brake, pneumatically operated, Braking power Z-axis < 0.1 mm stationary, 50 mm at full speed
Stop position damping	Adjustable or parabolic spring for opposite side + pneumatic spring respectively
Installation options	X-axis, X,Y-axis, Z-axis
Maximum adjustment force	285 N
Electronics	
Limit position switch	inductive with adjustable limit position, circular plug connection (8x8x40)
Magnetic strip	isel MS 50
Linear motor	isel LS 50, iron core linear motor with magnetic rails, with or without audio signal, nominal current 6 A, peak current 15 A, max. feed force 600 N
Length measuring system	isel IMS, incremental measuring system
Motor / encoder connection	Protection type IP 67, M23 connecting socket for motor and encoder cable
Energy chain	Optional
Supported interfaces	Standard RS422 A ₁ /A ₂ , B ₁ /B ₂ optional z ₁ /z ₂ , Option SIN/COS 1V _{ss} +20%, -40%, Z and /Z Right-sign

Dimensioned drawing

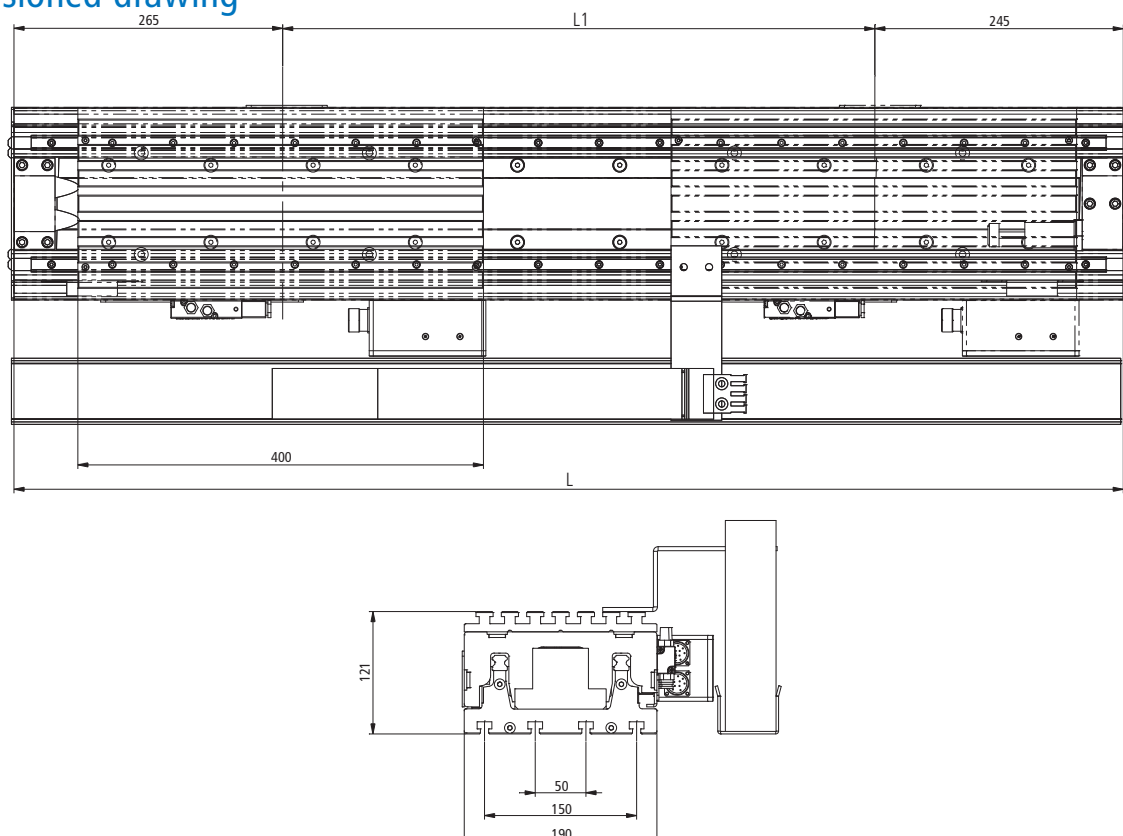

Functional overview Linear unit with toothed belt drive

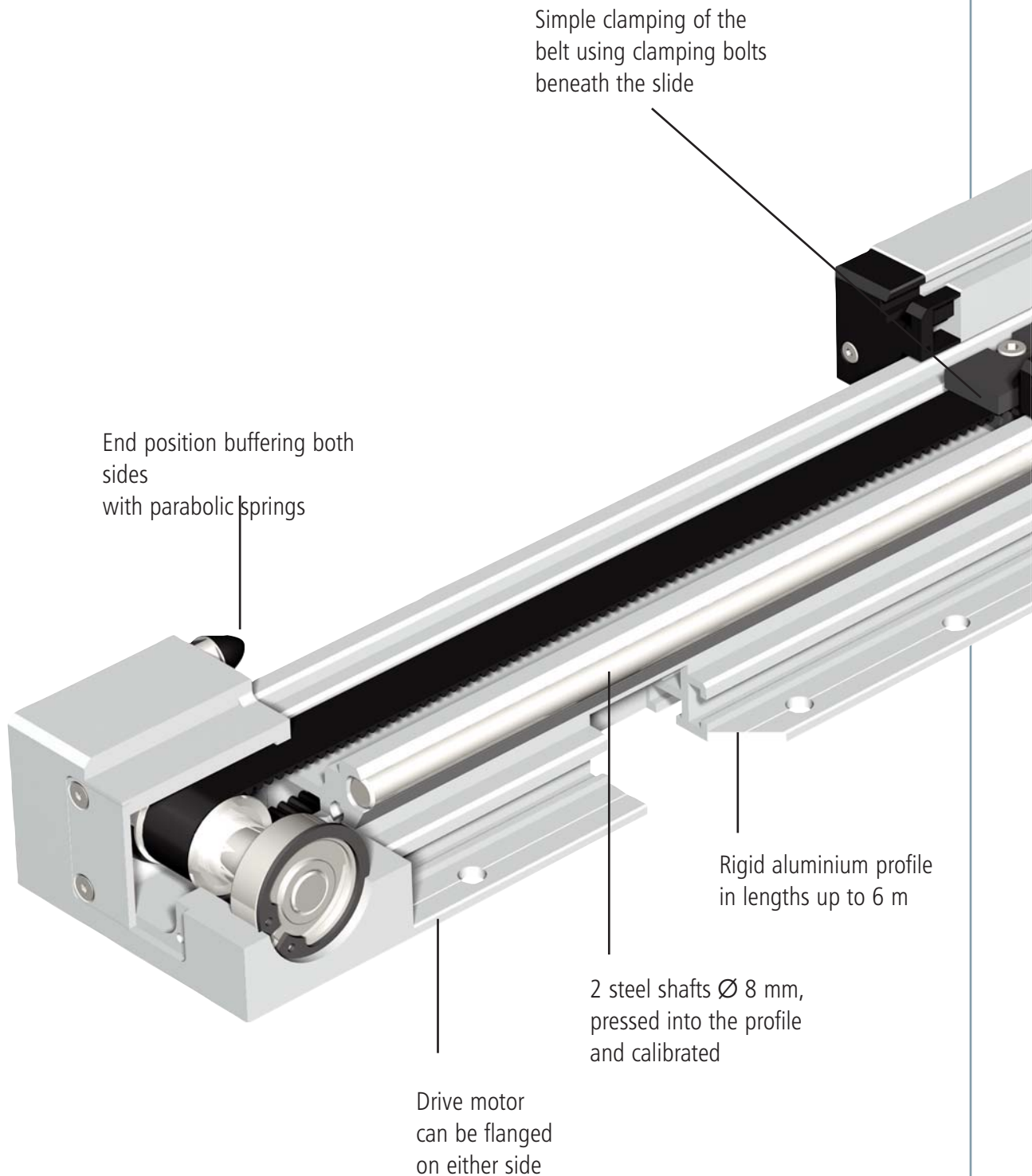

Functional overview

Linear unit with toothed belt drive

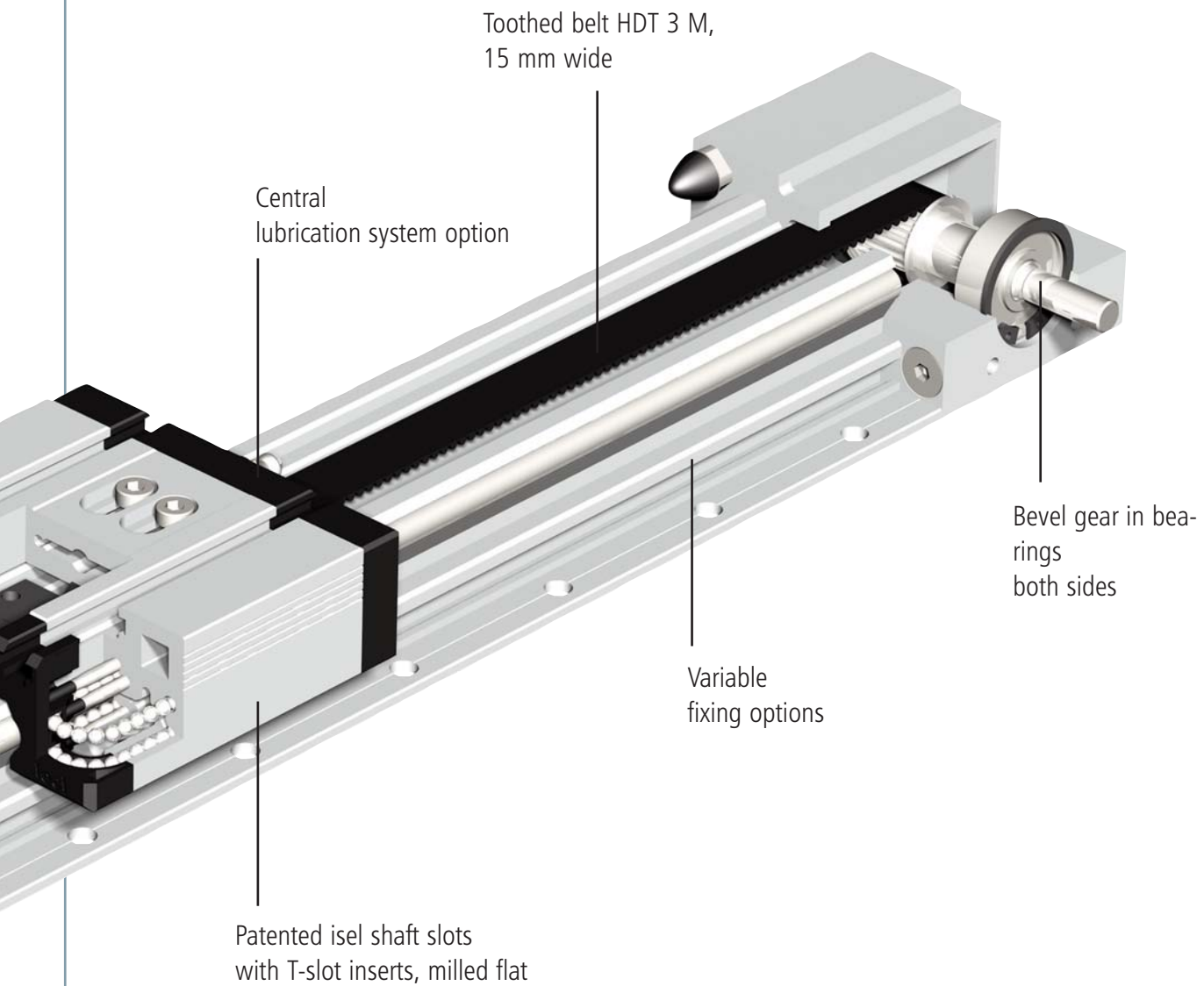

Linear units

with toothed belt drive

LEZ 1

Guides and shaft slides also available stainless.



with shaft slide



with trolley

Features

- Aluminium profile, miniature linear guide LFS-8-2
- No-play feed with toothed belt drive
 - toothed belt with 3 mm interval, width 9 mm
- Feed per turn: 60 mm
- Repeatability less than or equal to ± 0.2 mm
- Max. feed: 1.5 m/s

Accessories can be found on pages B-86.

Options:

- Special 100 mm raster lengths to order, max. 6000 mm
- Securing with integrated M6 tapped rail, raster 50 mm

Ordering key

232 005 XXXX

Drives/Slides

Trolley

- 8 = without motor, with shaft slide
- 9 = without motor, with trolley

Profile lengths LFS-8-2 (mm)

- 298, 398, 498, 598, 675, 698, 798, 998, 1498, 1798, 1998, 2498, 2998
 (e. g. 398 mm = 040
 675 mm = 068)
 Option: up to 6000 mm

Technical specification

Belt type.....HTD 3M, width 9 mm
 Slide weight.....0.430 kg
 Weight without drive module.....1000 mm = 3 kg
 specific weight of the toothed belt.....0.0225 kg/m
 Trolley weight.....1.03 kg
 specific guide weight.....0.200 kg/100 mm
 Effective \varnothing of the synchronous disks.....19.10 mm
 Moment of inertia of the synchronous discs..... 5.585×10^{-7} kgm²
 Feed per turn.....60 mm

Drive module with stepper motor MS-045 HT



Drive module with stepper motor MS-135 HT



Load diagram

Permitted accelerated weights relative to the belt strength.*

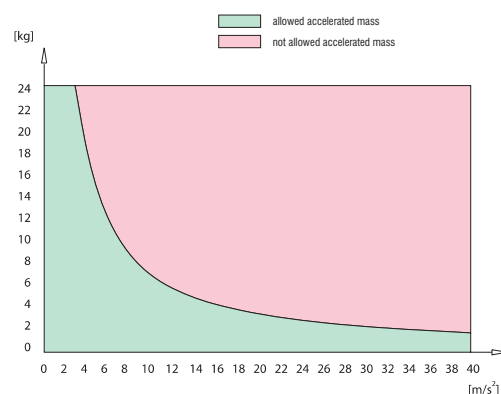

* with vertical construction, the acceleration due to gravity ($g = 9.81$ m/s²) must be taken into account

Bending data is on page B-7.

Linear units

with toothed belt drive

LEZ 1

Dimensioned drawings

without motor, with shaft slides

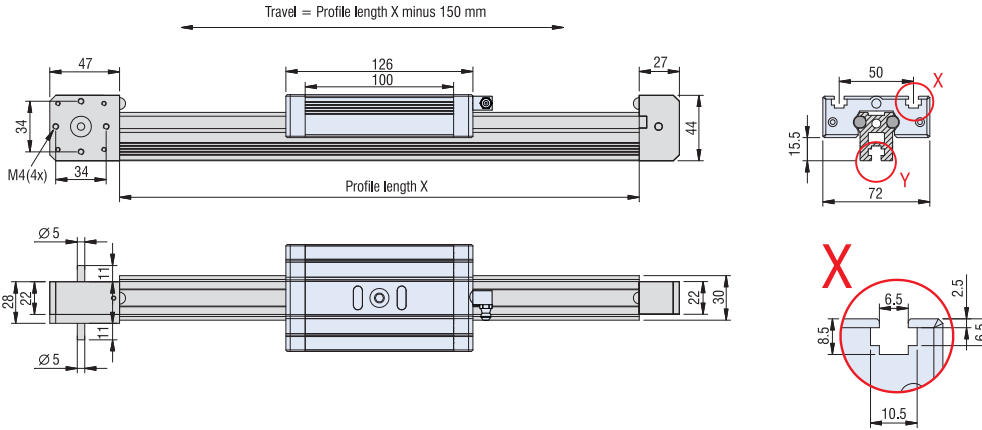

without motor, with trolley

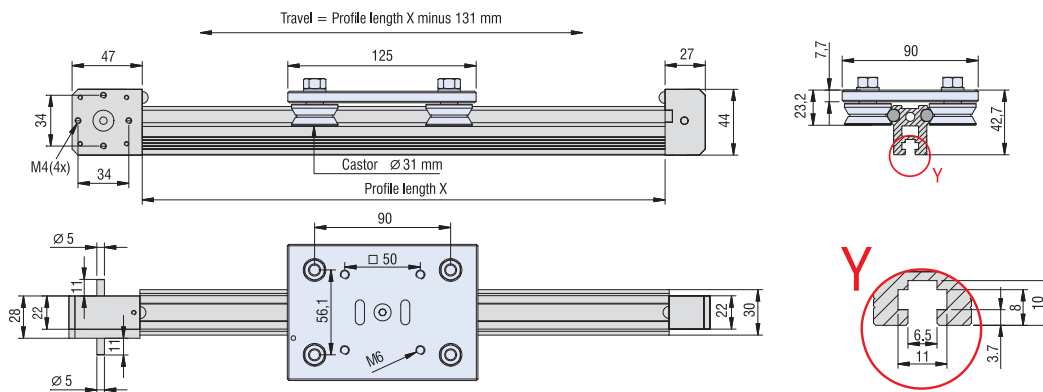

Motor modules (Motor pin assignments are on Page B-60.)

Drive module with stepper motor
MS-045 HT (direct drive)
Feed: 60 mm / turn

Part no.: **396048 3015**

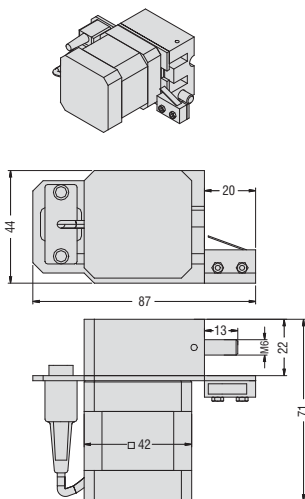

Total length with motor module: profile length + 94 mm

Drive module with stepper motor
MS-045 HT (reduction 2:1)
Feed: 30 mm / turn

Part no.: **396049 3015**

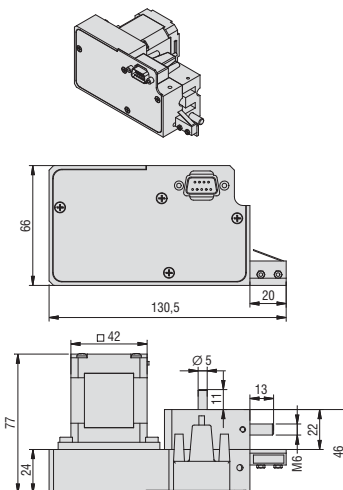

Total length with motor module: profile length + 138 mm

Drive module with stepper motor
MS-135 HT (reduction 2:1)
Feed: 30 mm / turn

Part no.: **396056 3015**

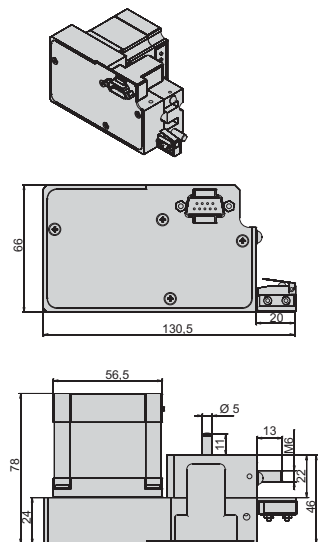

Linear units with toothed belt drive

LEZ 1G Blue Line



Features

- Aluminium profile with midget linear guide LFS-8-1
- Clearance-free feed with timing belt feed axis - timing belt with 3 mm pitch, width 15 mm
- Feed 2.4 m/s, at the most
- Shaft slide WS 1 L 126 x W 72 mm
- Repetitive accuracy less or equal ± 0.2 mm
- Limit and/or reference switch accuracy < 0.1 mm
- Available in lengths up to 2.05 m
- Motor can be mounted on both sides due to an extended shaft end on the driving side
- Numerous combination possibilities due to additional special and angle profiles
- Integrated reference switch

Ordering key

232 1XX XXXX

Motor

- 0 = without motor
- 3 = with step motor MS 200-HT
- 4 = with DC-Servo motor DC 100
- 5 = with EC-Servo motor EC 60-S

Driving Side

- 0 = motor connection, right*
 - 1 = motor connection, left*
- * motor flange for drive is mounted on the right resp. left side

Slide / Connection

- 0 = with standard slide profile
- 1 = with connecting slides for compound tables
- 2 = with angle slide, right
- 3 = with angle slide, left

Basic Profile Length (mm)

- 450, 550, 650, 750, 850, 950, 1050, 1150, 1250, 1350, 1450, 1550, 1650, 1750, 1850, 1950, 2050
- (e.g. 450 mm = 045
2050 mm = 205)

Travel = L -307 mm

Technical specification

- Belt version.....HTD 3M, width 15 mm
- Mass of slide0.730 kg
- Weight without drive module1,000 mm $\hat{=}$ 6.25 kg
- Nominal mass of timing belt0.0375 kg/m
- Nominal weight of feed axis0.440 kg/100 mm
- Effective diameter of the synchronized pulleys..... \varnothing 15.28 mm
- Moment of inertia of the synchronized pulleys $1.461 \cdot 10^{-6}$ kgm²
- Feed per revolution.....48 mm

Basic profile + LFS-8-1

- Moment of inertia I_x 68.73 cm⁴
- Moment of inertia I_y 15.92 cm⁴
- Moment of resistance W_x 17.18 cm³
- Moment of resistance W_y 5.49 cm³

Load Diagramm

Permitted accelerated weights relative to the belt strength.*

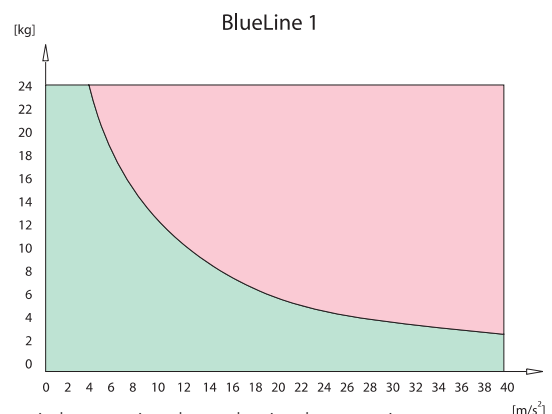

* with vertical construction, the acceleration due to gravity ($g = 9.81$ m/s²) must be taken into account

Linear units

with toothed belt drive

LEZ 1G Blue Line

Dimensioned drawings

without motor, with profile carriage plate and angle slide

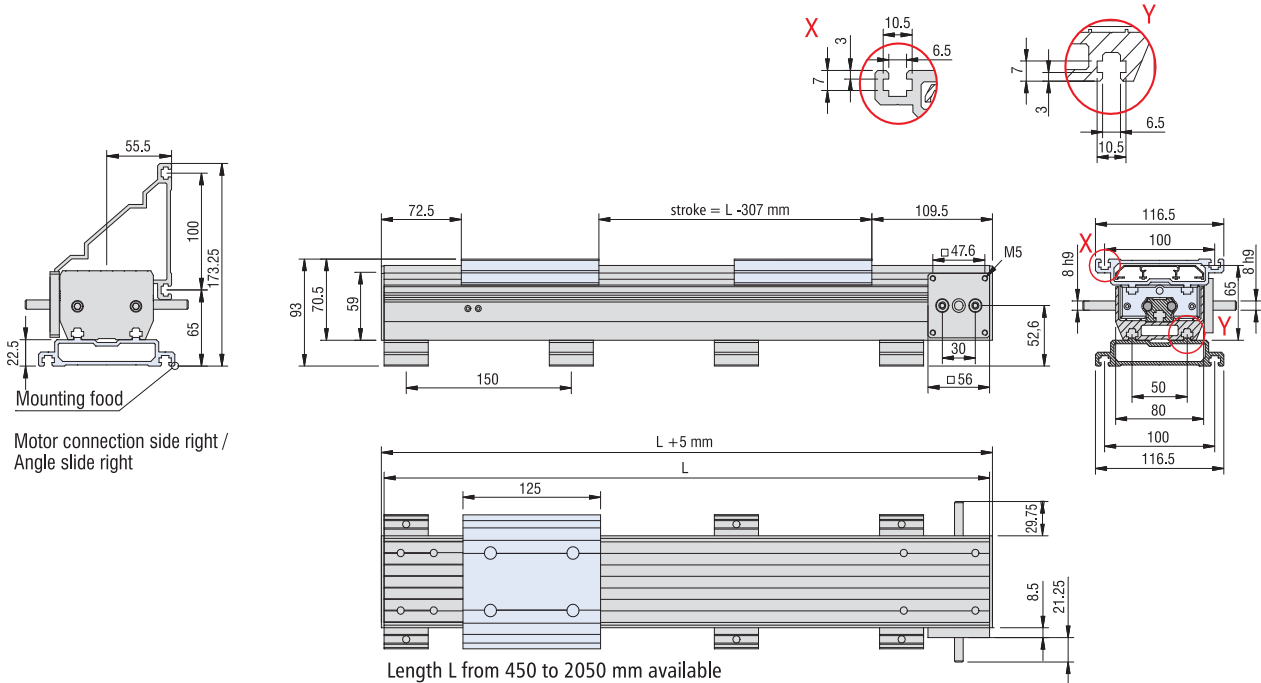

Motor modules (Motor pin assignments are on page B-60)

Drive module with stepper motor
MS 200-HT

Part-no.: **396058 4060**

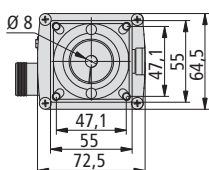
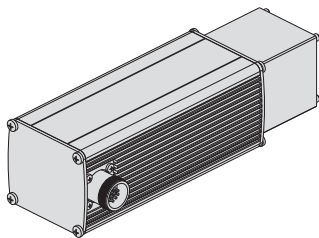

Drive module with servo motor
DC 100

Part-no.: **396112 3060**

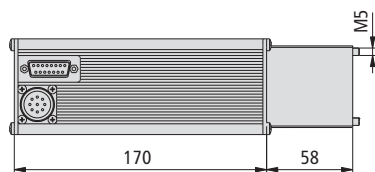
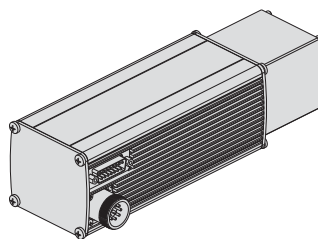

Drive module with servo motor
EC 60-S

Part-no.: **396415 3061**

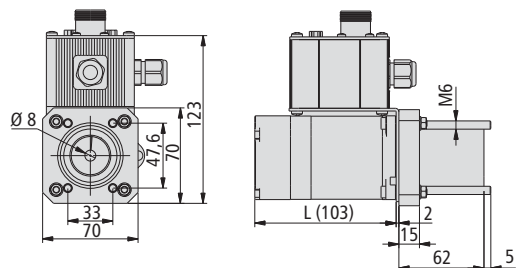
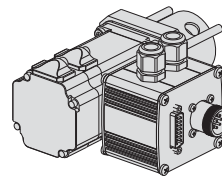

Linear units with toothed belt drive

LEZ 2

Guides
and shaft slides
also available in a stain-
less version



with shaft slide



with trolley

Features

- Aluminium profile with miniature linear guide LFS-8-5
- No-play feed with toothed belt drive - toothed belt with 5 mm interval, width 25 mm
- Max. feed. 5 m/s
- Shaft slides WS 3, L 176 × W 130 mm
- Feed per turn: 70 mm
- Repeat accuracy less than or equal to ± 0.2 mm
- available in lengths up to 6,000 mm

Accessories can be found on pages **B-86**

Options:

- Special 100 mm raster lengths available to order, max. 6000 mm
- Also as direct drive with
 - stepper motor
 - Servomotor
- Overrun limit switch with lead (only integrated in conjunction with drive module)

Ordering key

232 002 XXXX

Profile lengths (mm)

696, 996, 1496, 1996,
2496, 2996

(e. g. 696 mm = 070
1496 mm = 150)

Option: up to 6000 mm

Drives/Slides, Trolley

8 = without motor, with shaft slides

9 = without motor, with trolley

Technical specification

Belt type.....	HTD 5M, width 25 mm
Slide weight.....	0,940 kg
Weight without drive module.....	1000 mm ≅ 7.9 kg
specific weight of the toothed belt.....	0.09 kg/m
Roller carriage weight.....	2.03 kg
specific guide weight.....	0.472 kg/100 mm
Effective diameter of the synchronous disks.....	Ø 22.28 mm
Moment of inertia of the synchronous disks.....	5.58·10 ⁻⁶ kgm ²
Feed per turn.....	70 mm

Linear guide rail LFS-8-5

Moment of inertia I _x	137,48 cm ⁴
Moment of inertia I _y	27,98 cm ⁴
Resistance torque W _x	23,91 cm ³
Resistance torque W _y	13,09 cm ³

Load diagram

Permitted accelerated weights relative to the belt strength.*

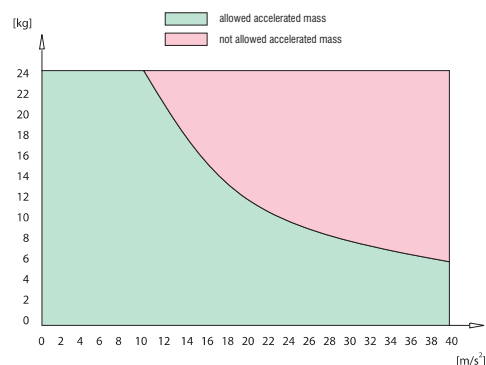

* with vertical construction, the acceleration due to gravity (g = 9.81 m/s²) must be taken into account

Drive module
with servo motor
EC 60 L



Linear units

with toothed belt drive

LEZ 2

Dimensioned drawings

without motor, with shaft slides

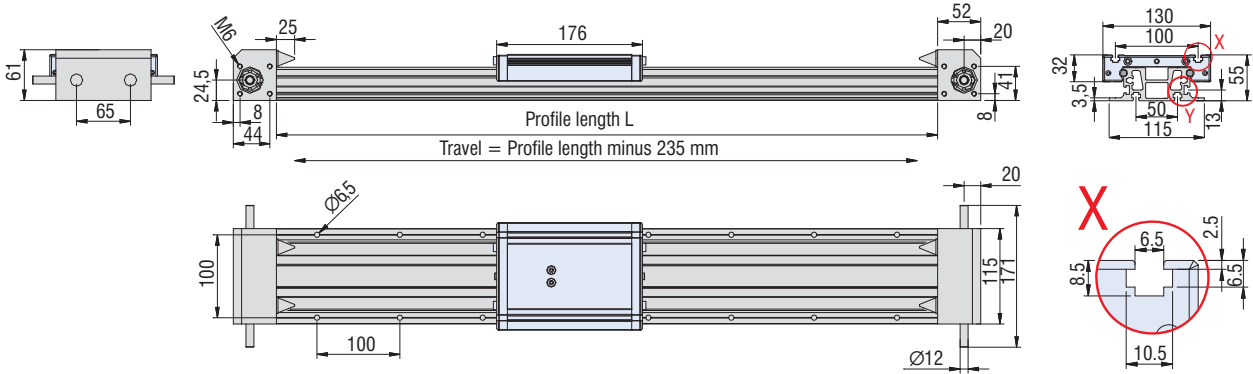

without motor, with trolley

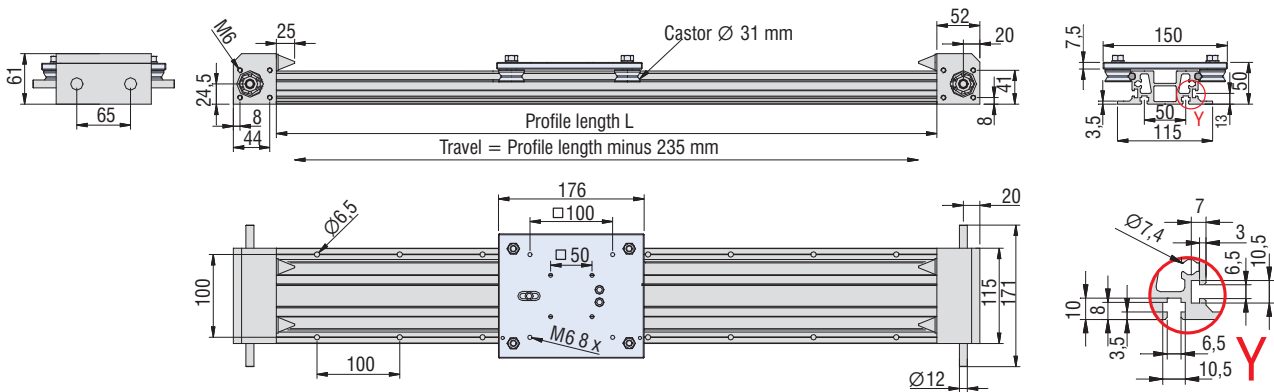

Motor modules (Motor pin assignments are on Page B-60)

Drive module with stepper motor
MS-600 HT (reduction 2:1)
Feed: 35 mm / turn

Part no.: **396086 3060**

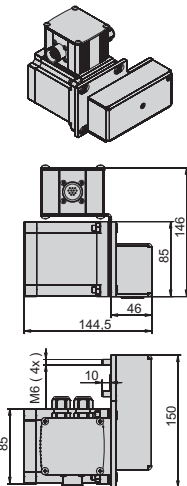

Drive module with EC servomotors
(Reduction 2:1)
Feed: 35 mm / turn

Part number	Motor module	Length L
396 415 3260	EC 60S with brake	151.5 mm
396 415 3060	EC 60S without brake	198.5 mm
396 423 3060	EC 60L	186.5 mm
396 444 3070	EC 86S	177.5 mm
396 466 3070	EC 86L	202.5 mm

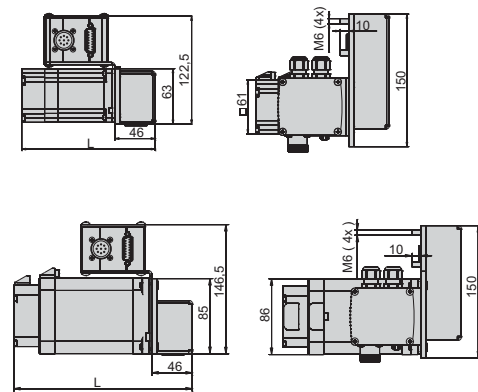
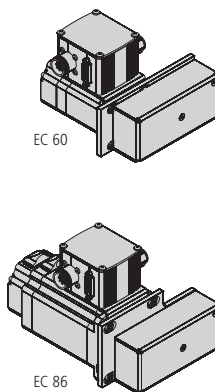

Linear units with toothed belt drive

LEZ 3

Guides
and shaft slides
also available stainless.



with shaft slide



with trolley

Features

- Aluminium profile, miniature linear guide LFS-8-4
- No-play feed with toothed belt drive, toothed belt with 5 mm interval, width 25 mm
- Max. feed. 5 m/s
- Shaft slides WS3, L176 × W130 mm
- Feed per turn: 70 mm or 150 mm
- Repeat accuracy less than or equal to ± 0.2 mm
- Limit or reference switch accuracy < 0.1 mm
- Available in lengths up to 6,000 mm
- Motor modules can be flange-mounted on left or right side

Accessories can be found on page B-86.

Options:

- Special 100 mm raster lengths available to order, max. 6000 mm

Ordering key

23200X XXXX

Profile lengths (mm)

698, 998, 1498, 1998, 2498, 2998

(e. g. 698 mm = 070
1498 mm = 150)

Feed

6 = 150 mm / turn

7 = 70 mm / turn

Slides, trolley

0 = with shaft slides

1 = with trolley

Technical specification

Belt type.....	HTD 5M, width 25 mm
Slide weight.....	0.940 kg
Weight without drive module.....	1000 mm $\hat{=}$ 10.5 kg
specific weight of the toothed belt.....	0.09 kg/m
Roller carriage weight.....	2.03 kg
specific guide weight.....	0.648 kg/100 mm
Feed per turn.....	70 mm or 150 mm
Effective diameter of the synchronous disks	
Feed 70 mm/turn.....	22.28 mm
Feed 150 mm/turn.....	47.75 mm
Moment of inertia of the synchronous disks	
Feed 70 mm/turn.....	5.58E-6 kgm ²
Feed 150 mm/turn.....	1,796.10 ⁻⁴ kgm ²

Load diagram

Permitted accelerated weights relative to the belt strength.*

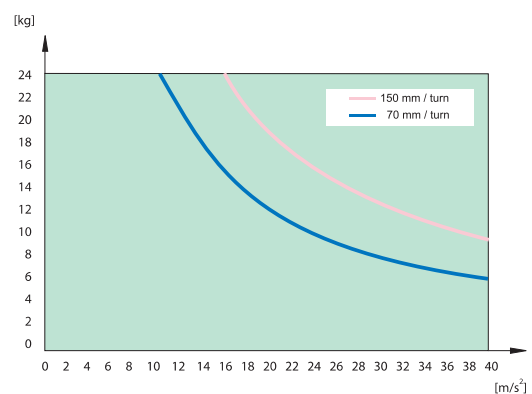

* with vertical construction, the acceleration due to gravity (g=9.81 m/s²) must be considered

Bending data can be found on page B-27.

Linear units

with toothed belt drive

LEZ 3

Dimensioned drawings

with shaft slides

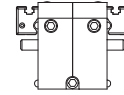
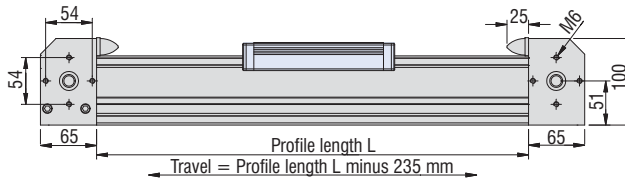
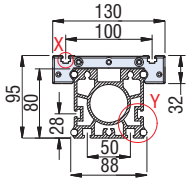

Feed: 70 mm/turn

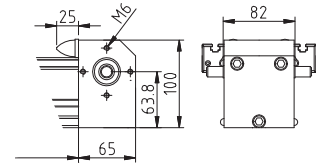
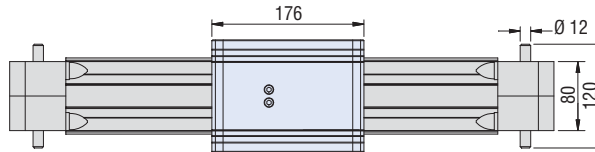
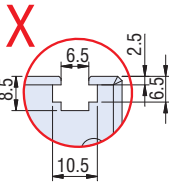

with trolley

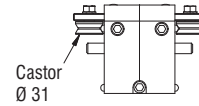
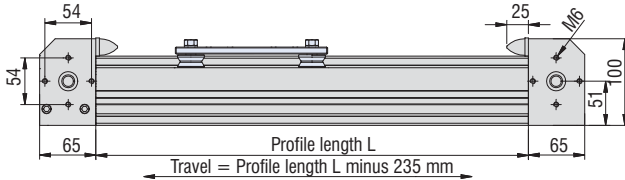
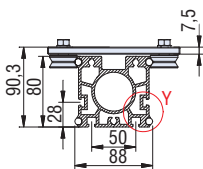

Castor
Ø 31

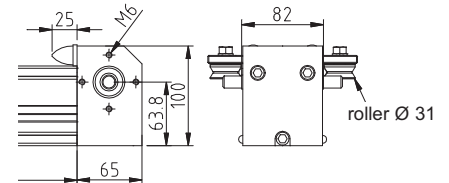
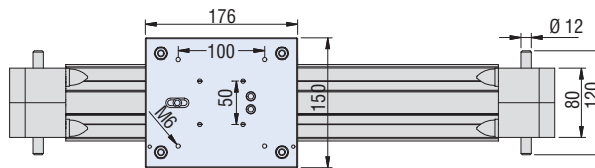
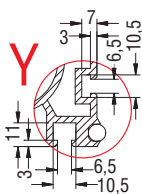

roller Ø 31

Motor modules

(Motor pin assignments are on Page B-60)

Drive module with stepper motor
(direct drive)

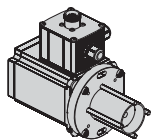

Part number	Motor module	
396 085 0060	MS 600 HT	right
396 085 0061	MS 600 HT	left
396 088 0060	MS 900 HT	right
396 088 0061	MS 900 HT	left

Drive module with EC servomotor
EC 60 and EC 86 (direct drive)

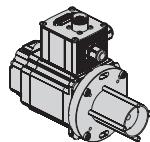

Part number	Motor module
396 423 006012	EC 60L
396 444 0070	EC 86S
396 466 0070	EC 86L

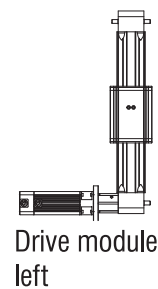

Drive module
left

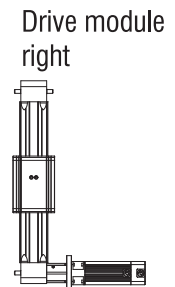

Drive module
right

Linear units

with toothed belt drive

LEZ 9



with shaft slide

Features

- Aluminium profile
Linear guide LFS-8-7
- no-play feed with toothed belt drive
- toothed belt with 3 mm interval
Width 15 mm
- Max. feed. 2 m/s
- Shaft slides WS 11
L 96 × W 95 mm
- Feed per turn: 60 mm
- Repeatability less than or equal to ± 0,2 mm
- inductive limit switches

Accessories can be found on page B-86.

Options:

- Special length in 100 mm raster to order

Ordering key

23201X XXXX*

Version

- 0 ... with shaft side
- 1 ... with trolley

Profile length (mm)

- 496, 996, 1496, 1996, 2496, 2996
- (e.g. 496 mm = 0050
1496 mm = 0150)

Note:

Please order drive modules separately on the listed part numbers and specify here, whether the delivery should take place with or without attachment.

Technical specification

Belt type.....	HTD 3M, width 15 mm
Slide weight.....	0.4 kg
Weight without drive module.....	1000 mm = 4.4 kg
specific weight of the toothed belt.....	0.04 kg/m
specific guide weight.....	0.29 kg/100 mm
Effective diameter of the synchronous disks.....	Ø 19.1 mm
Moment of inertia of the synchronous disks.....	5.58E-6 kgm ²
Feed per turn.....	60 mm

Linear guide rail LFS-8-7

Moment of inertia I _x	29.34 cm ⁴
Moment of inertia I _y	10.86 cm ⁴
Resistance torque W _x	7.52 cm ³
Resistance torque W _y	5.68 cm ³

Load diagram

Permitted accelerated weights relative to the belt strength.*

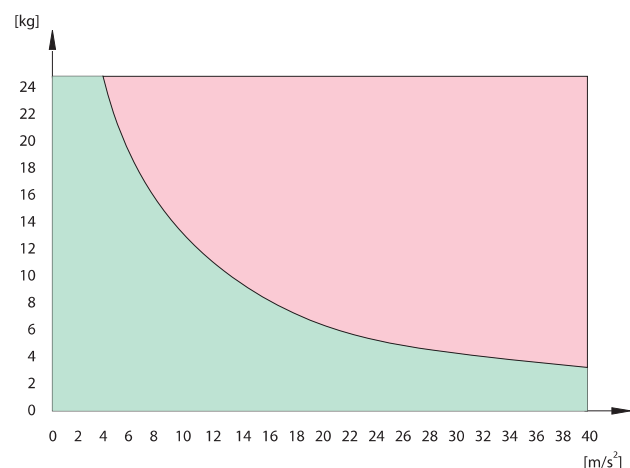

* with vertical construction, the acceleration due to gravity (g=9.81 m/s²) must be considered

Linear units

with toothed belt drive

LEZ 9

Dimensioned drawings

with shaft slides

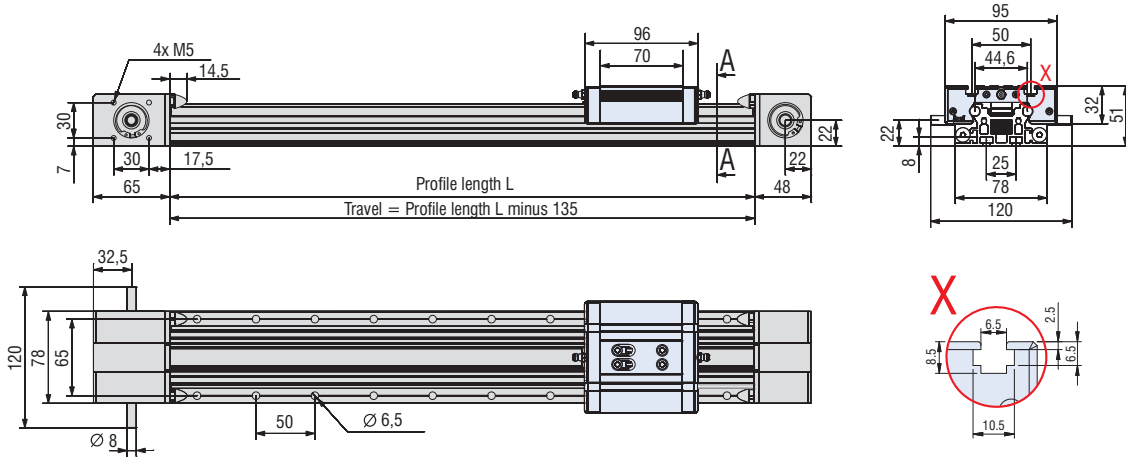

with trolley

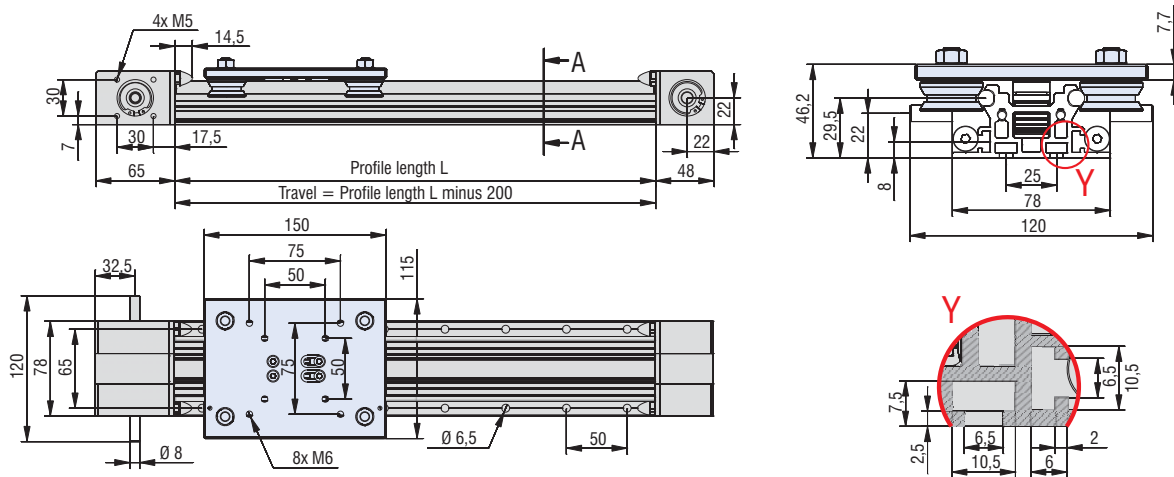

Motor modules (Motor pin assignments are on page B-60.)

Drive module with stepper motor
MS 200 HT
(reduction 2:1)
Feed: 30 mm / turn

Part number	Motor module	
396 058 3017	MS 200 HT	right
396 058 3018	MS 200 HT	left

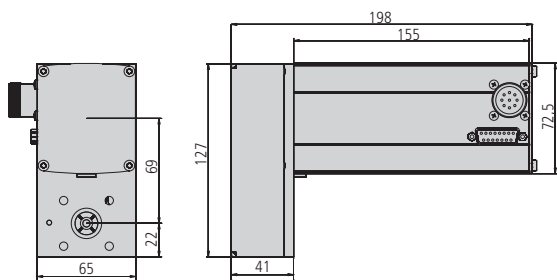
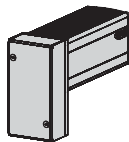

Drive module with servo motor DC 100
(reduction 2:1)
Feed: 30 mm / turn

Part-no: 396112 3063

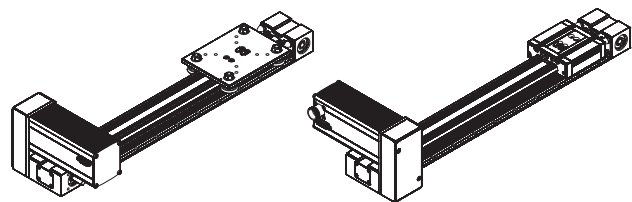
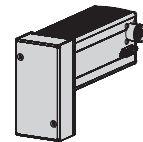
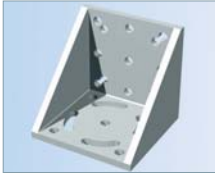

Figure:
LEZ 9 with trolley and
stepper motor MS 200 HT
left mounted

Figure:
LEZ 9 with shaft slide and
servo motor DC 100
right mounted

Accessories

LEZ 1



Angle bracket

- for LEZ 1

Part-no.: **209110 0010**



20/30 coupling

- for LEZ 1
- 1 VE = 1 coupling

Part-no.: **218001 5081**

Shaft slides 1/70

- L 96 x W 72 x H 28.5 mm
- Clamping surface plane milled, T-slide thread M6
- central greasing option, adjustable for no play
- Weight: 0.35 kg
- Option: stainless steel version

Part-no.: **223100 0070**
stainless steel: **223101 0070**

Transmission shaft

Length 1 m
Part-no.: **227008 1000**

LEZ 1G Blue Line

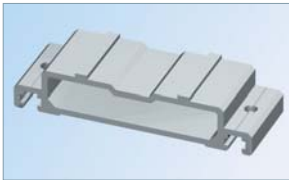

Feet

- for LEZ 1G
- 116.5 x 40 x 22.5 mm
- 1 VE = 2 pieces

Part-no.: **232199 0001**

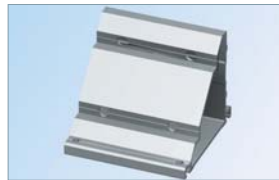

Mounting bracket

- including fixing material
- for LEZ 1G

Part-no.: **232199 0002**



30/40 coupling

- for LEZ 1G Blue Line
- 1 VE = 1 coupling

Part-no.: **218002 8081**

Transmission shaft

Length 1 m
Part-no.: **227008 1000**

LEZ 2

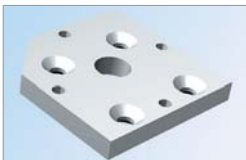

Motor mounting plate

- for LEZ 2
- including fixing material
- for direct drive

Part-no.: **232199 0004**

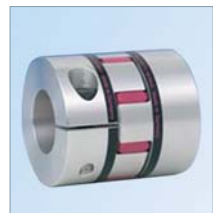

Coupling for transmission shaft

- for LEZ 2
- 1 VE = 2 pieces couplings

Part-no.: **218050 0002**

Transmission shaft \varnothing 25 mm

Length 1 m
Part-no.: **219001 0125**

Length 2 m
Part-no.: **219001 0225**

Vertical bearing for transmission shaft

VE 1 piece
Part.-no.: **896202 5562**

LEZ 3

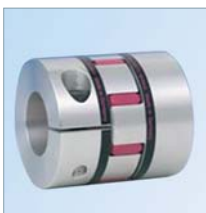

Coupling for transmission shaft

- for LEZ 3
- 1 VE = 2 pieces couplings

Part-no.: **218050 0002**

Transmissions shaft \varnothing 25 mm

Length 1 m
Part-no.: **219001 0125**

Length 2 m
Part-no.: **219001 0225**

Vertical bearing for transmission shaft

VE 1 piece
Part.-no.: **896202 5562**

LEZ 9



30/40 couplings

- for LEZ 9
- 1 VE = 1 coupling

Part-no.: **218002 8081**

Shaft slide WS 11/70

- L 96 x W 96 x H 32 mm
- Clamping surface plane milled, T-slide thread M6
- central greasing option, adjustable for no play
- Weight: 0.4 kg
- Option: stainless steel version

Part-no.: **223111 0070**
stainless steel: **223111 1070**

Transmissions shaft

Length 1 m
Part-no.: **227008 1000**

Examples in use

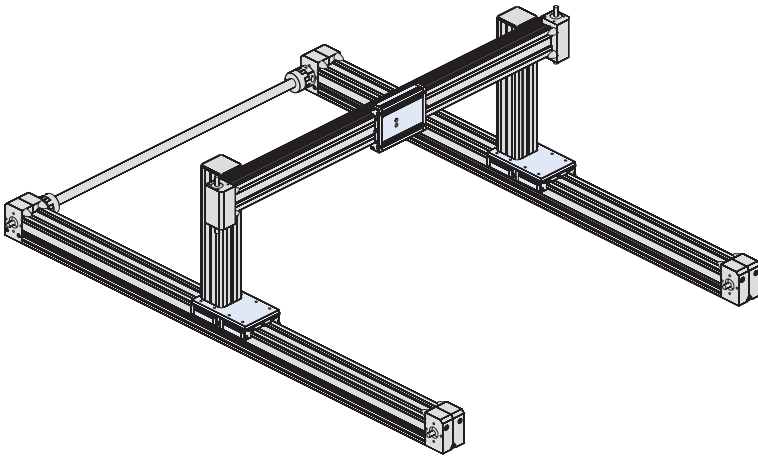

2-axis H-design

- 2 x LEZ 3
- 1 x LEZ 2
- Transmission shaft

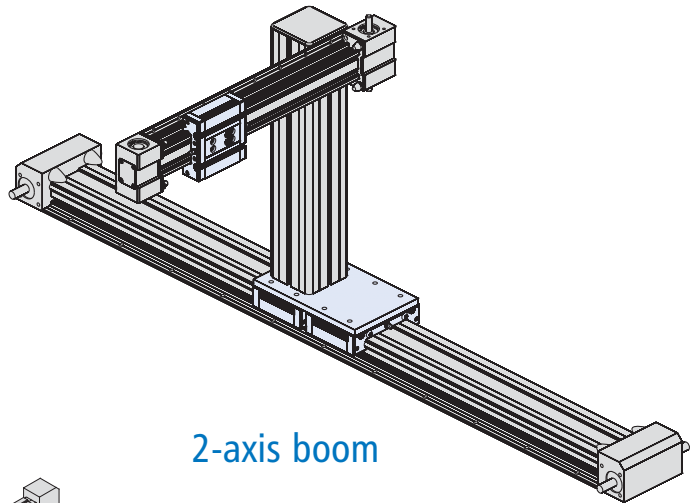

2-axis boom

- 1x LEZ 2
- 1x LEZ 9

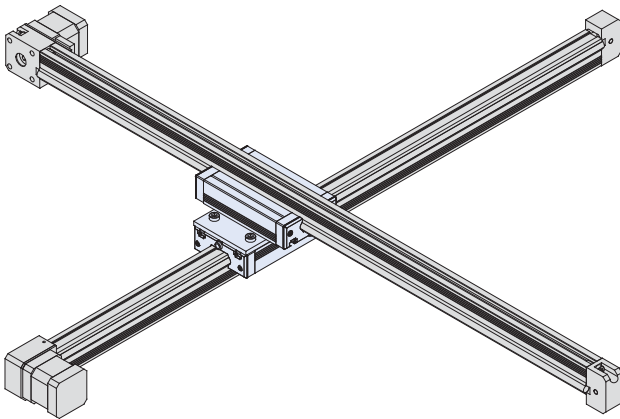

Crossbench LEZ 1

- 2 x LEZ 1

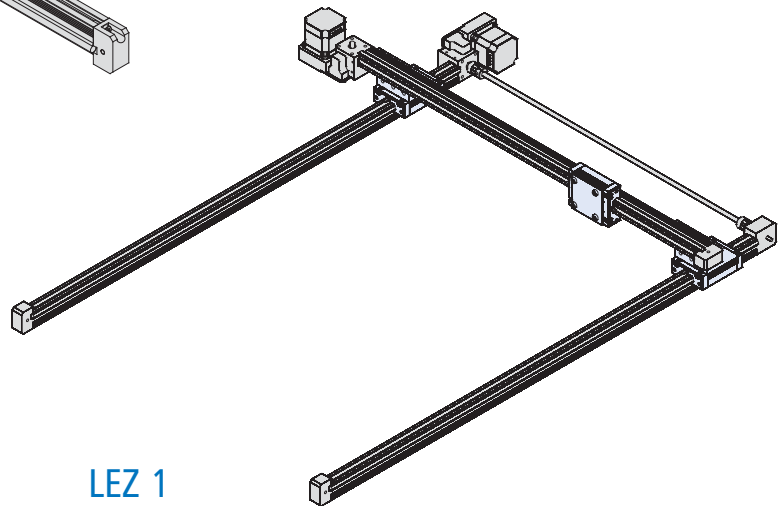

LEZ 1

- 2-axis flatbed configuration

Rotational units

Overview

Torquemotor iRD

B-90



RDH-M

Indexing table / Rotary unit

B-92



RDH-S

Indexing table / Rotary unit

B-94



RDH-XS

Indexing table / Rotary unit

B-96



DSH-S

Rotary tilting unit

B-98



RF 1

Indexing table

B-100



Rotational units

Overview

MD 1 Miniature rotary unit

B-102



ZD 30 Rotary unit

B-104

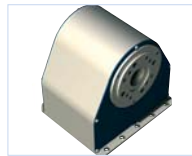

ZR 20 Indexing table

B-106

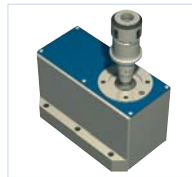

ZDS 2030

B-107



Pin assignments

B-108

Transported loads

B-109

Machining forces

Feed

CAD data can be found on



Torque motors

iRD 80



iRD 80/50 vertical design



iRD 80/50 horizontal design

Features

- improved storage of the rotor shaft for enhanced load-carrying capability
- horizontal and vertical design
- no mechanical transmission elements
- high torque in a compact design
- very good repeatability and positioning
- very good concentricity and axial run-out
- large hollow shaft
- measuring system directly on the rotor shaft

Technical specifications

	iRD 80/50
intermediate circuit voltage [V]	330
current [A]	6
peak current [A]	15
rated torque [Nm]	10
peak torque [Nm]	17
max. speed [rpm.]	800
rotor inertia [kg/cm ²]	34
concentricity ± [mm]	0.03
axial run-out ± [mm]	0.03
numbers of poles	20
permissible static load [kN]	1.7
permissible dynamic load [kN]	1.5
breakdown torque for bearings [Nm]	150
protection class	IP50
torque constant [Nm/A]	1.13
accuracy ± [arc sec]	65
repeatability ± [arc sec]	3.5
thermal protection	PTC
encoder option 1 [Inc/r] incremental	20000

Order data

Torque motor iRD 80/50

horizontal Part-no.: **267110 0020**

vertical Part-no.: **267110 0010**

Accessories

motor cable

Part-no.: **392307 XXXX**

encoder cable

Part-no.: **392325 0500**

Visit us on our website and look at our current product video:



Torque motors

iRD 80

Dimensioned drawings

vertical design

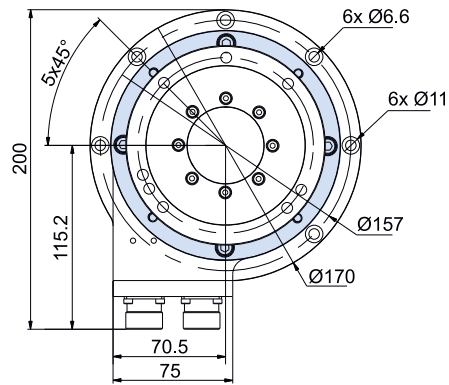
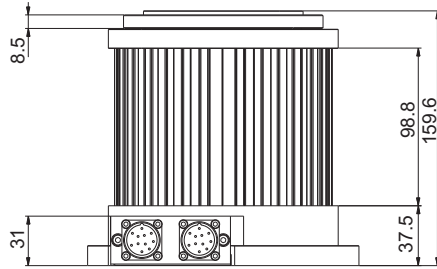

horizontal design

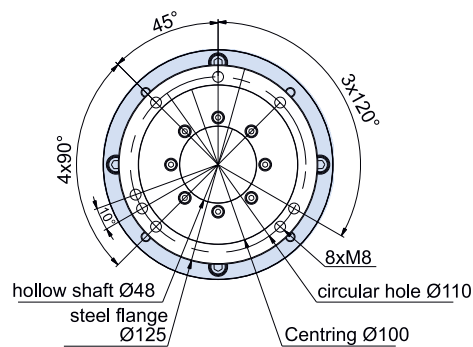
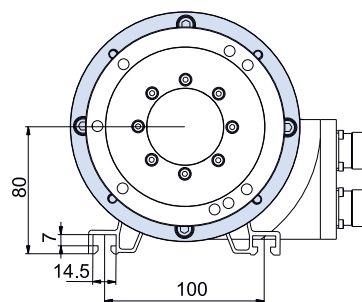
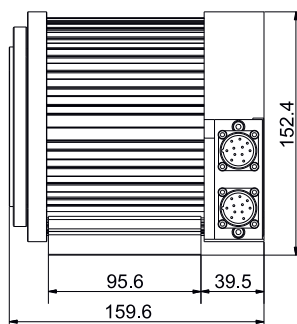

Indexing table / Rotary unit

RDH-M

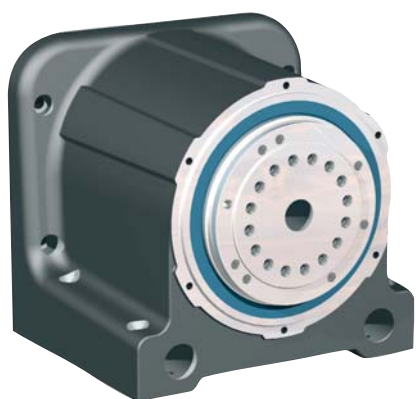

RDH-M as Indexing table
(solid shaft design)

RDH-M as Rotary unit
(hollow shaft design)



Features

- With precision transmission
 - High load capacity, rigid drive bearing
 - Absence of play and high torsional rigidity
- Reduction 1:51 or 1:101
- Stepper or servomotor
- Protection class IP 65
- Stainless design
- Transfer accuracy < 1 minute of arc
- Repeatability < ± 6 seconds of arc
- Available in solid or hollow shaft design
- No maintenance

For pin assignment see page B-108

For transport loads see page B-109

Ordering key

2 6 6 2 X X 0 X 0 0

Flanged shaft

- 0 = solid shaft
- 1 = hollow shaft

Transmission reduction

- 0 = 101
- 1 = 51

Motors

- 0 = Stepper motor MS 200 HAT with encoder (400 imp., 3-channel, RS422)
- 3 = brushless EC servomotor EC 60S
- 4 = brushed DC servomotor DC 100
- 5 = Stepper motor without encoder

Accessories



Chuck assembly

3-jaw chuck \varnothing 125
Part no.: **269063 2125**
* including flange



Aluminium T-slot plate

\varnothing 240 mm/PT 25
Part no.: **269050 0240**

 \varnothing 365 mm/PT 25
Part no.: **269050 0365**



Tailstock unit RE M

Part no.: **269100 2100**
(1000 mm)
Part no.: **269100 2150**
(1500 mm)
Part no.: **269100 2200**
(2000 mm)

Indexing table / Rotary unit

RDH-M

Technical specification

	stepper motor MS 200 HT *		EC servomotor EC 60S (brushless)		DC servo motor DC 100 (brushed)	
Reduction ratio	1:51	1:101	1:51	1:101	1:51	1:101
Nominal output speed [1/min]	4	2	22	11	22	11
Max. output speed [1/min]	at 1500 Hz (225 1/min)		at 1100 1/min			
	24	12	59	30	59	30
Nominal torque [Nm]	at 8000 Hz		--			
	24	46	9	17	7	14
Max. torque (short term) [Nm]	at 1500 Hz		--			
	--	--	42	80	39	73
Rated holding torque (static load) [Nm]	55	108	26	51	15	30
Max. transmission load [Nm]	98	157	98	157	98	157
Dynamic load factor C [N]	Limit for repeatable peak torque					
Static load factor C ₀ [N]	21800					
Weight [kg]	35800					
	13.7					

* Values for half-step operation

Dimensioned drawings

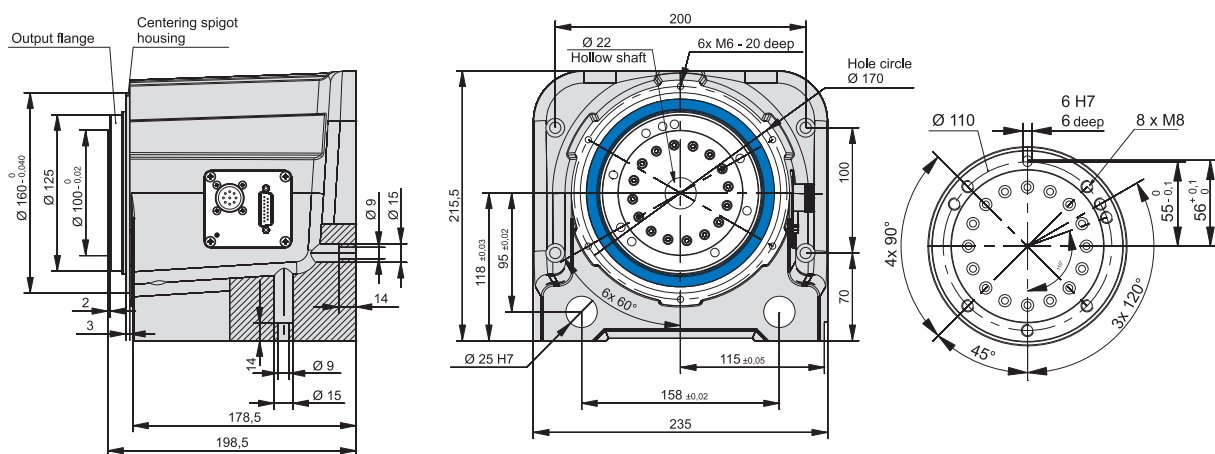

Versions	Part no.	L	A
Tailstock unit RE-M 1000 mm	269100 2100	1110	624.5
Tailstock unit RE-M 1500 mm	269100 2150	1610	1124.5
Tailstock unit RE-M 2000 mm	269100 2200	2110	1624.5

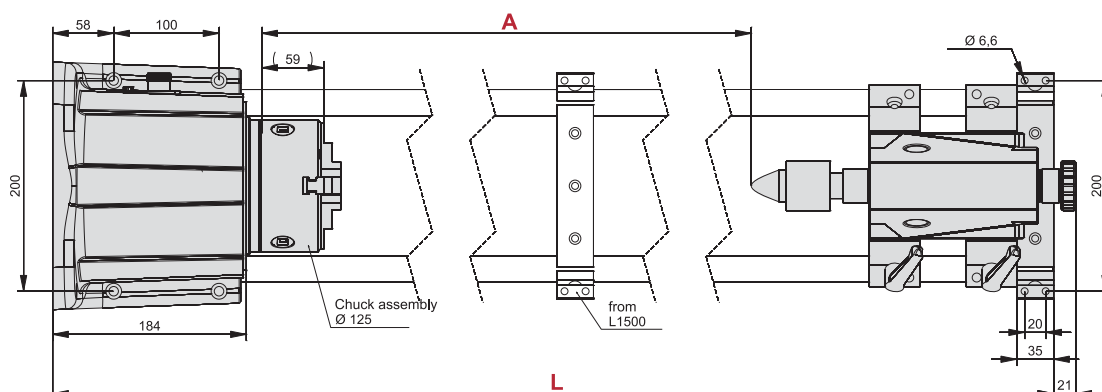

Indexing table / Rotary unit

RDH-S



RDH-S as Indexing table
(solid shaft design)

RDH-S as Rotary unit
(hollow shaft design)



Features

- With precision transmission
 - High load capacity, rigid drive bearing
 - Absence of play and high torsional rigidity
- Reduction 1:51 or 1:101
- Stepper or servomotor
- Protection class IP 65
- Stainless design
- Transfer accuracy < 1.5 minute of arc
- Repeatability < ± 6 seconds of arc
- Available in solid or hollow shaft design
- No maintenance

For pin assignment see page **B-108**

For transport loads see page **B-109**

Ordering key

2 6 6 1 X X 0 X 0 0

Flanged shaft

- 0 = solid shaft
- 1 = hollow shaft

Transmission reduction

- 0 = 101
- 1 = 51

Motors

- 0 = Stepper motor MS 045 HT with encoder (400 imp., 3-channel, RS422)
- 2 = brushless DC servomotor RE 40
- 3 = brushless EC servomotor EC 42
- 5 = Stepper motor without encoder

Accessories



Chuck assembly

3-jaw chuck \varnothing 65

Part no.: **269060 3065***

3-jaw chuck \varnothing 80

Part no.: **269063 2080***

3-jaw chuck \varnothing 100

Part no.: **269063 2100***

* including flange



Circular plate

\varnothing 150

Part no.: **269 050 0150**



Tailstock unit RE S

for RDH-S

Part no.: **269100 1020** (200 mm)

Part no.: **269100 1030** (300 mm)

Part no.: **269100 1040** (400 mm)

Part no.: **269100 1050** (500 mm)

Indexing table / Rotary unit

RDH-S

Technical specification

	stepper motor MS 045 HT *		EC servomotor EC 42 (brushless)		DC servo motor RE 40 (with brushes)	
Reduction ratio	1:51	1:101	1:51	1:101	1:51	1:101
Nominal output speed [1/min]	4	2	22	11	22	11
	at 1500 Hz (225 1/min)		at 1100 1/min		at 1100 1/min	
Max. output speed [1/min]	24	12	59	30	69	35
	at 8000 Hz		--		--	
Nominal torque [Nm]	7	11	4.8	9.2	4.6	9
	at 1500 Hz		--		--	
Max. torque (short term) [Nm]	--	--	7	11	7	11
Rated holding torque (static load) [Nm]	7	11	7	11	7	11
Max. transmission load [Nm]	18	28	18	28	18	28
	Limit for repeatable peak torque					
Dynamic load factor C [N]	5800					
Static load factor C ₀ [N]	8600					
Weight [kg]	4.6					

* Values for half-step operation

Dimensioned drawings

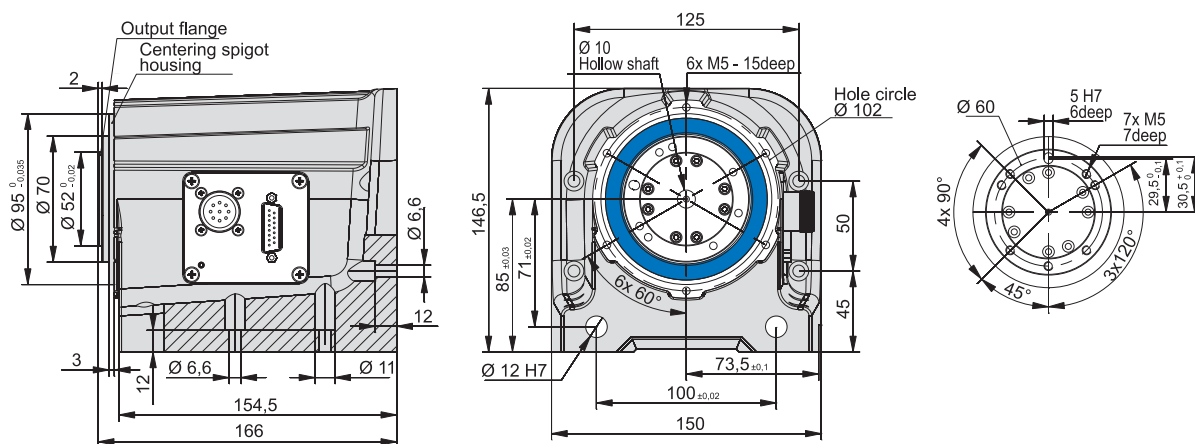

Versions	Part no.	L	A
Tailstock unit RE-S 200 mm	269100 1020	370	128
Tailstock unit RE-S 300 mm	269100 1030	470	228
Tailstock unit RE-S 400 mm	269100 1040	570	328
Tailstock unit RE-S 500 mm	269100 1050	670	428

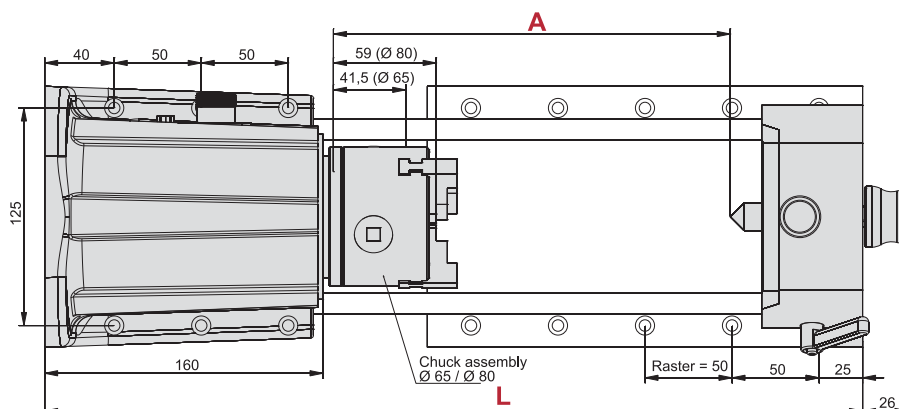

Indexing table/Rotary unit

RDH-XS



RDH-XS as Rotary unit

RDH-XS as Indexing table



Features

- With precision transmission
 - High load capacity, rigid drive bearing
 - Absence of play and high torsional rigidity
- Reduction 1:50 or 1:100
- Stepper or servomotor
- Protection class IP 65
- Stainless design
- Transfer accuracy <math>< 2</math> minutes of arc
- Repeatability <math>< \pm 1</math> minute of arc
- No maintenance

For pin assignment see page B-108

For transport loads see page B-109

Ordering key

2 6 6 0 0 X 0 X 0 0

Transmission reduction

0 = 100

1 = 50

Motors

0 = Stepper motor MS 045 HT with encoder (400 imp., 3-channel, RS422)

2 = brushed DC servomotor RE 40

3 = brushless EC servomotor EC 42

5 = Stepper motor without encoder

Accessories

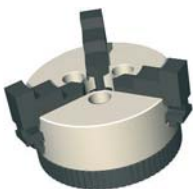

Chuck assembly

3-jaw chuck \varnothing 65Part no.: **269060 4065***

* including flange



Tailstock unit RE XS

for RDH-XS

Part no.: **269100 0020** (200 mm)Part no.: **269100 0030** (300 mm)Part no.: **269100 0040** (400 mm)Part no.: **269100 0050** (500 mm)

Indexing table/Rotary unit

RDH-XS

Technical specification

	stepper motor MS 045 HT *		EC servomotor EC 42		DC servo motor RE 40	
	1:50	1:100	1:50	1:100	1:50	1:100
Reduction ratio	1:50	1:100	1:50	1:100	1:50	1:100
Nominal output speed [1/min]	5	2	22	11	22	11
	at 1500 Hz (225 1/min)		at 1100 1/min		at 1100 1/min	
Max. output speed [1/min]	24	12	59	30	70	35
	at 8000 Hz (1200 rpm)		--			
Nominal torque [Nm]	5	7	5	7	5	7
	at 1500 Hz (225 1/min)		--			
Max. torque (short term) [Nm]	--	--	5	7	5	7
Rated holding torque (static load) [Nm]	5	7	5	7	5	7
Max. transmission load [Nm]	9	14	9	14	9	14
	Limit for repeatable peak torque					
Dynamic load factor C [N]	392					
Static load factor C ₀ [N]	392					
Weight [kg]	2.3					

* Values for half-step operation

Dimensioned drawings

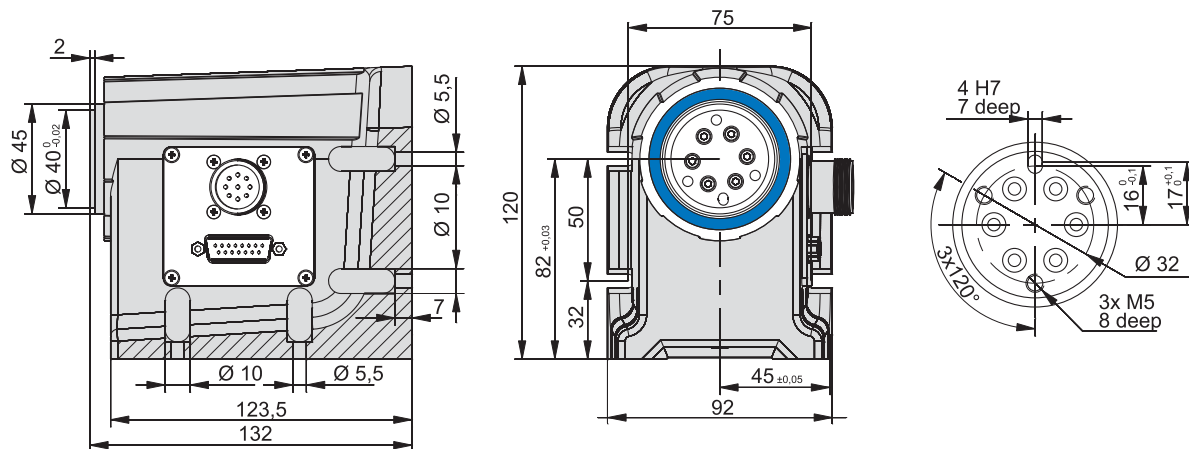

Versions	Part no.	L	A
Tailstock unit RE-XS 200 mm	269100 0020	325	117
Tailstock unit RE-XS 300 mm	269100 0030	425	217
Tailstock unit RE-XS 400 mm	269100 0040	525	317
Tailstock unit RE-XS 500 mm	269100 0050	625	417

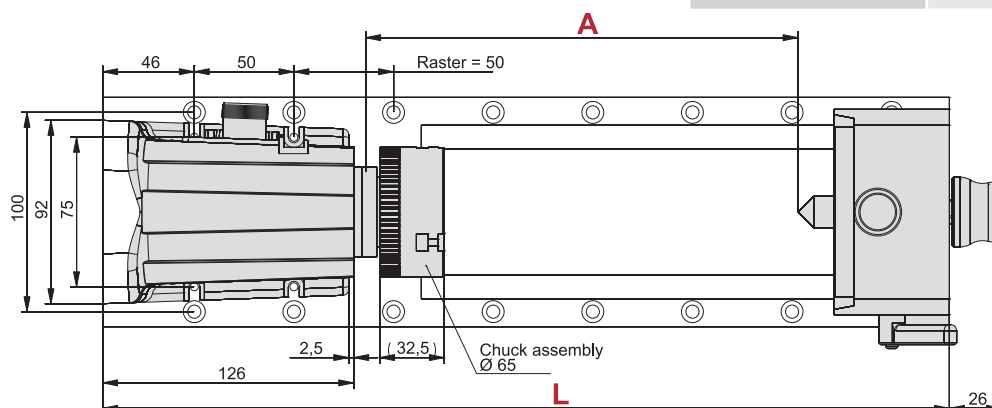

Rotary tilting unit

DSH-S



Features

- With precision transmission
 - High load capacity, rigid drive bearing
 - Absence of play and high torsional rigidity
- With rotary unit RDH-S
- Reduction 1:51 or 1:101
- Stepper or servomotor
- Protection class IP 65
- Stainless design
- Transfer accuracy < 1.5 minute of arc
- Repeatability < ± 6 seconds of arc
- No maintenance
- Swivel range continuously variable

For pin assignment see page **B-108**

For transport loads see page **B-109**

Ordering key

2 6 5 4 1 X X 0 0 0

Motors

- 0** = Stepper motor MS 045 HT with encoder (400 imp., 3-channel, RS422)
- 2** = brushed DC servomotor RE 40
- 3** = brushless EC servomotor EC 42
- 5** = Stepper motor without encoder

Transmission reduction

- 0** = 1 : 101
- 1** = 1 : 51

Accessories



Chuck assembly
3-jaw chuck Ø 65

Part no.: **269060 3065***

3-jaw chuck Ø 80

Part no.: **269063 2080***

3-jaw chuck Ø 100

Part no.: **269063 2100***

* incl. Flange



Circular plate

Ø 150

Part no.: **269 050 0150**

Rotary tilting unit

DSH-S

Technical specification

	stepper motor MS 045 HT *		EC servomotor EC 42		DC servo motor RE 40	
Reduction ratio	1:51	1:101	1:51	1:101	1:51	1:101
Nominal output speed [1/min]	4	2	22	11	22	11
	at 1500 Hz (225 1/min)		at 1100 1/min		at 1100 1/min	
Max. output speed [1/min]	24	12	59	30	69	35
	at 8000 Hz		--			
Nominal torque [Nm]	7	11	4.8	9.2	4.6	9
	at 1500 Hz		--			
Max. torque (short term) [Nm]	--	--	7	11	7	11
Rated holding torque (static load) [Nm]	7	11	7	11	7	11
Max. transmission load [Nm]	18	28	18	28	18	28
	Limit for repeatable peak torque					
Dynamic load factor C [N]	5800					
Static load factor C ₀ [N]	8600					
Weight [kg]	12 kg					

* Values for half-step operation

Dimensioned drawings

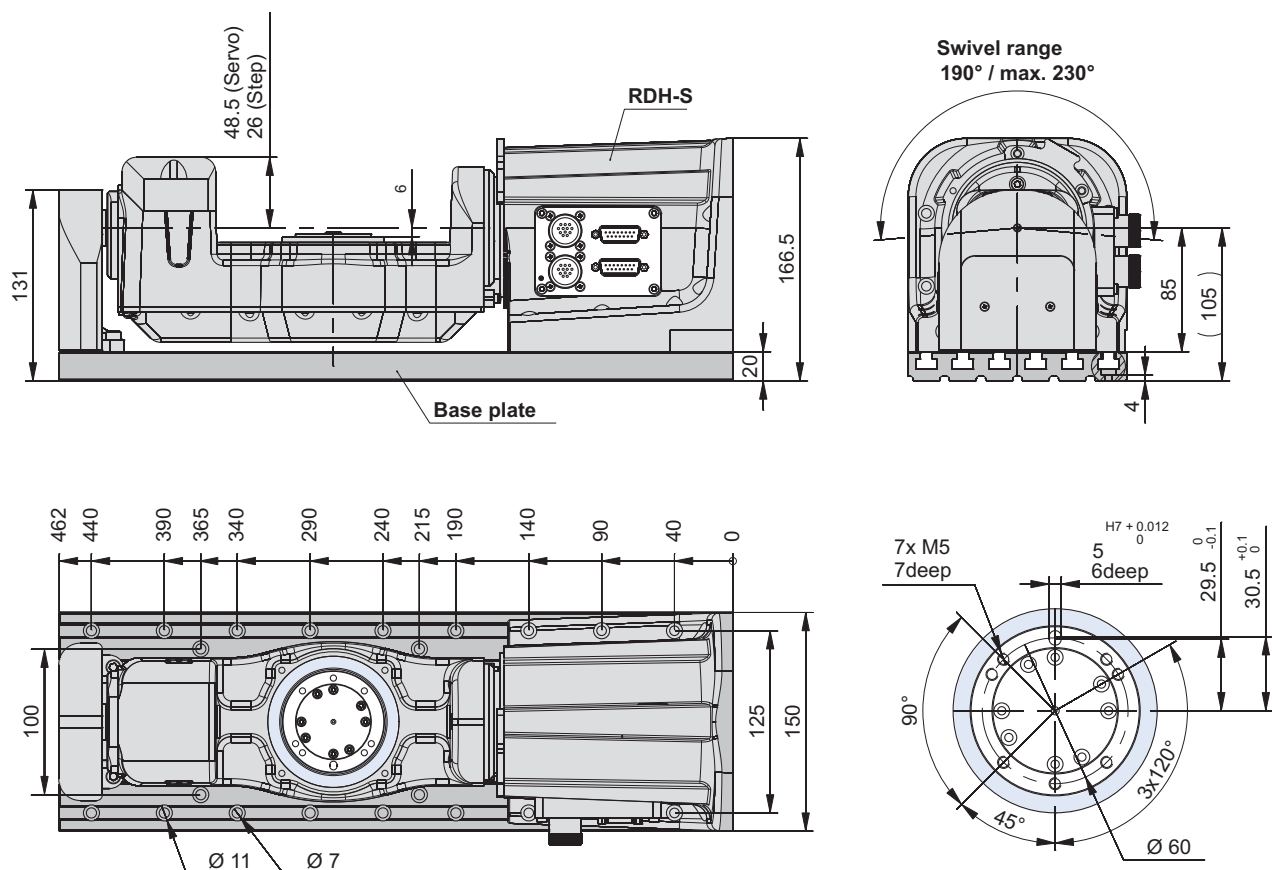

Indexing table

RF 1



Features

- Low play toothed belt drive with stepper or DC servo motor
- Reduction 1: 24 (standard)
- Weight: 14.6 kg

For pin assignment see page **B-108**
For transport loads see page **B-109**

Options:

- Reduction installation set
1 : 52 or 1 : 100
- Electromagnetic brake [60 Nm]
- Step motor drive with encoder
- CNC controller

Ordering key

2 6 0 2 4 X X X 0 0

Motors

- 1 = Stepper motor MS 200 HT without encoder
- 4 = brushed DC servomotor DC 100
- 5 = brushless EC servomotor EC 60S

Brake

- 0 = without brake
- 1 = magnetic brake

Plug

- 1 = servomotor: M23 + SubD15
- 2 = Stepper motor: SubD9

Accessories



Installation set

for reduction 1:52

Part no.: **269077 0001**

for reduction 1:100

Part no.: **269077 0002**



Aluminium T-slot plate

Ø 240 mm / PT 25

Part no.: **269050 0240**

Ø 365 mm / PT 25

Part no.: **269050 0365**



Chuck assembly

3-jaw chuck Ø 125

Part no.: **269063 2125**

Indexing table

RF 1

Technical specification

	stepper motor MS 200 HT *			Servomotor DC 100/EC 60S		
Reduction ratio	1:24	1:52	1:100	1:24	1:52	1:100
Output speed [1/min]	0 - 50	0 - 23	0 - 12	0 - 125	0 - 58	0 - 30
Operating torque (0 - 500 Hz) [Nm]	20	42	75	--		
Operating torque (500 - 1000 Hz) [Nm]	18	38	75	--		
Rated torque [Nm]	--			41070	13 / 22	25 / 42
Rated holding torque (static load) [Nm]	37	75	75	41102	16 / 26	30 / 50
Angle accuracy [°]	0.16					
Weight [kg]	14.6					

* Values for half-step operation

Dimensioned drawings

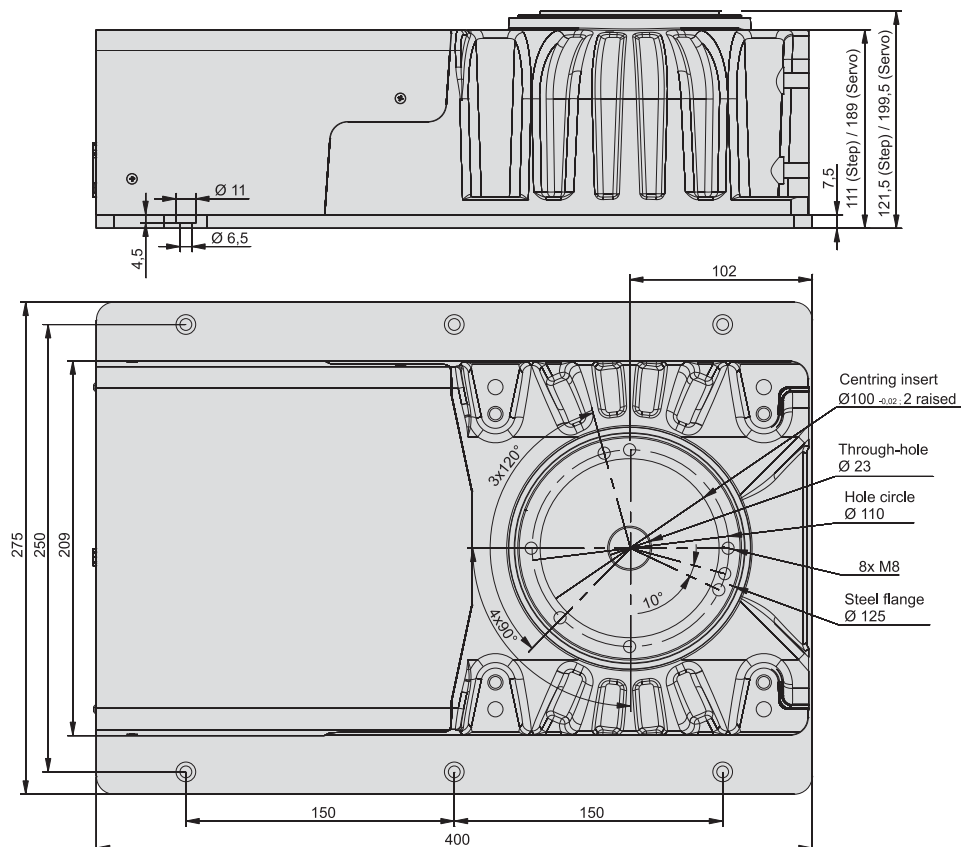

Mini rotary unit

MD 1

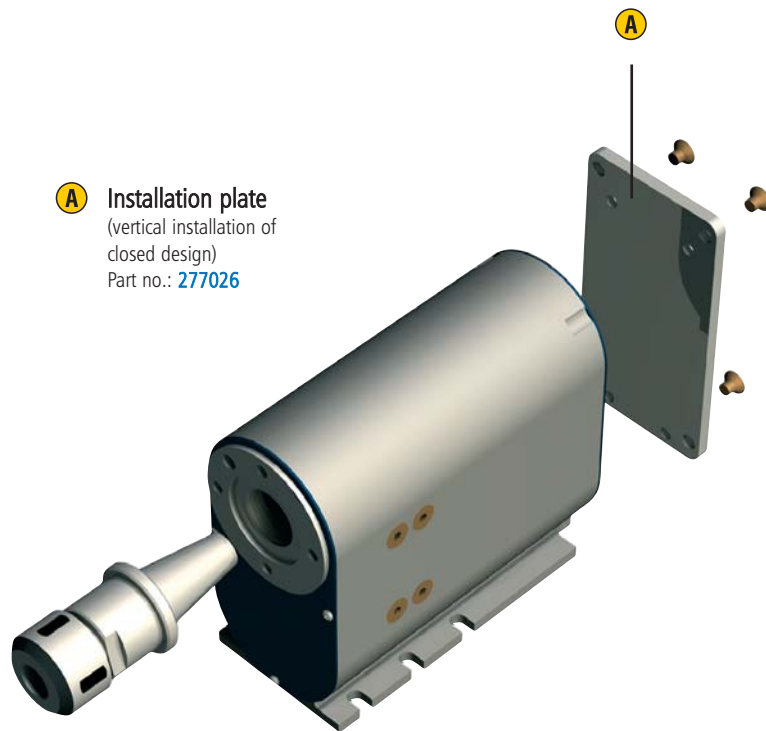

A **Installation plate**
(vertical installation of
closed design)
Part no.: **277026**

Features

- Low play toothed belt drive with stepper or DC servo motor
- Reduction 1 : 20
- Shaft $\varnothing 9$ mm with boring
- Housing flange with inner cone SK 20
- Weight:
depending on design, from 1.35 kg

For pin assignment see page **B-108**

For transport loads see page **B-109**

Options:

- Additional installation plate
(vertical installation possible)
- CNC controller

Ordering key

261010 0X10

Motors

0 = MS 045 HT stepper motor

2 = DC servomotor RE 40, with brushes

3 = brushless EC servomotor EC 42

Accessories

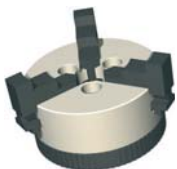

Chuck assembly

3-jaw chuck $\varnothing 65$

Part no.: **269060 2065***

* incl. Flange



Collet holder

Collet holder SK 20
for tools $\varnothing 3 - 13$ mm, with
installation ring

Part no.: **239122 9001**

Collets are on page 5-32.

Mini rotary unit

MD 1

Technical specification

	MS 045 HT stepper motor *	DC servomotor RE 40	EC servomotor EC 42
Reduction ratio	1:20	1:20	1:20
Output speed [1/min]	0 - 60	0 - 175	0 - 150
Operating torque (0 - 1600 Hz) [Nm]	8	--	--
Rated torque [Nm]	--	3	3.2
Rated holding torque (static load) [Nm]	14	3.9	4
Min. step (positional accuracy) [arcmin]	3.5	2	2
Gewicht [kg]		1.35	

* Values for half-step operation

Dimensioned drawings

	Length L per step	Length L for DC servo
closed design	129 mm	180 mm
closed with installation plate	133 mm	184 mm

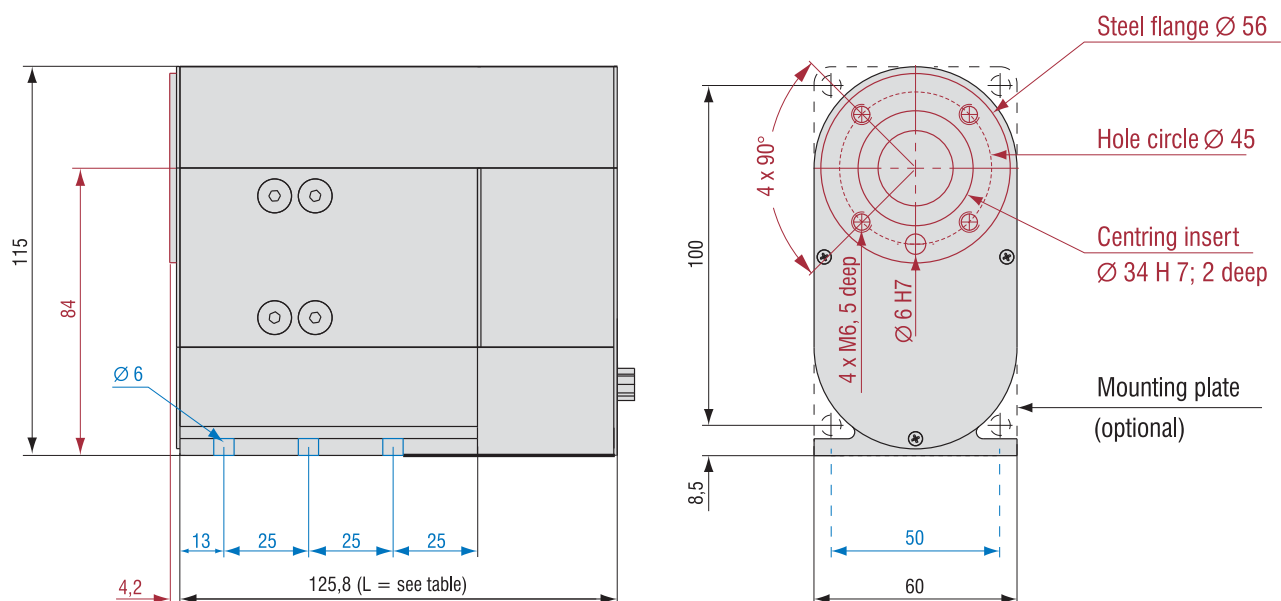
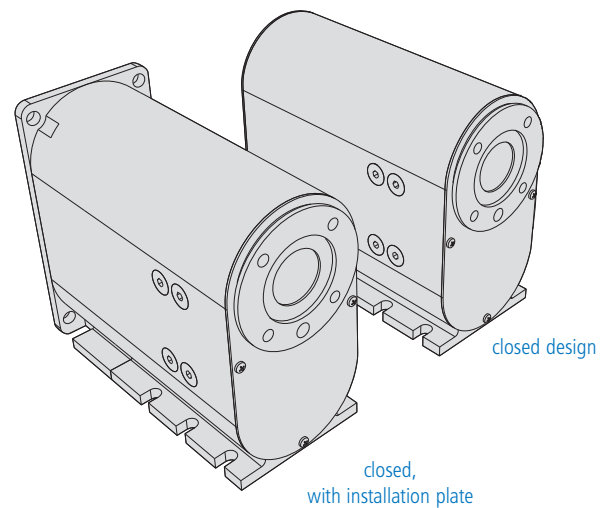

Rotary unit

ZD 30

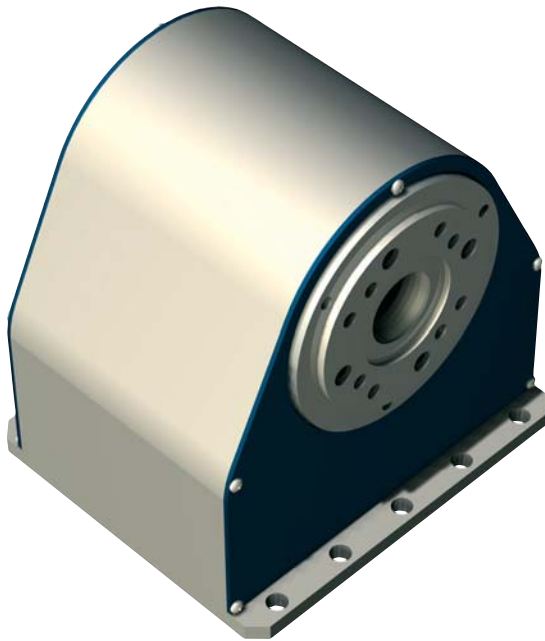

Features

- Low play toothed belt drive with Stepper motor
- Reduction 1 : 30
- Shaft with \varnothing 15 mm boring
- Housing flange with inner cone SK 20
- Weight: 2,9 kg

For pin assignment see page **B-108**
For transport loads see page **B-109**

Options:

- CNC controller via Sub D

Ordering data

ZD 30 rotary unit
Part no.: **261100 0000**

Accessories

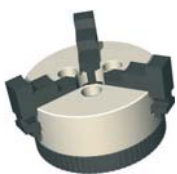

Chuck assembly
3-jaw chuck \varnothing 65
Part no.: **269060 2065***



Chuck assembly
3-jaw chuck \varnothing 80
Part no.: **269063 3080***



Collet holder
Clamping ring housing SK 20
for tools \varnothing 3 - 13 mm, with
installation ring
Part no.: **239122 9001**

Clamping rings are on
page E-38.



Tailstock unit RE-ZD30
200 mm Part no.: **269 100 1060** L 331
300 mm Part no.: **269 100 1070** L 431
400 mm Part no.: **269 100 1080** L 531
500 mm Part no.: **269 100 1090** L 631

* including flange

Rotary unit

ZD 30

Technical specification

		stepper motor MS 045 HT *
Reduction ratio		0.0625
Output speed	[1/min]	0 - 40
Operating torque (0 - 1600 Hz)	[Nm]	12
Rated holding torque (static load)	[Nm]	20
Min. step (positional accuracy)	[arcmin]	2.5
Weight	[kg]	2.9

* Values for half-step operation

Dimensioned drawings

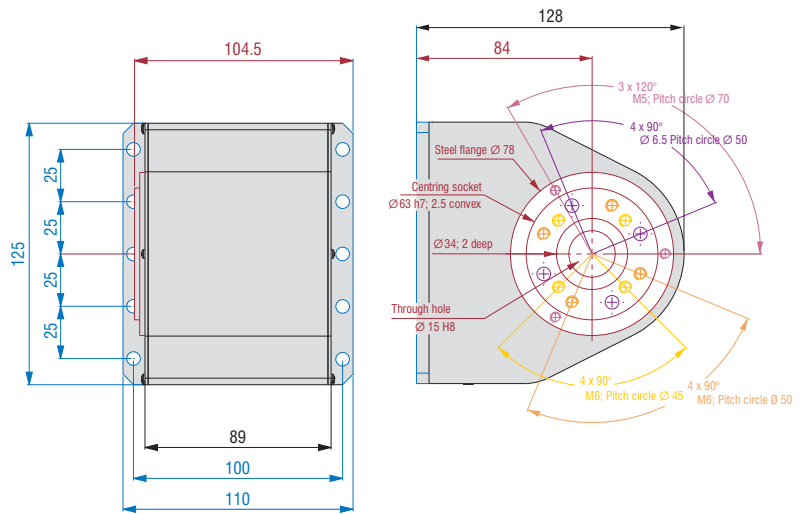

Tailstock unit RE-ZD30

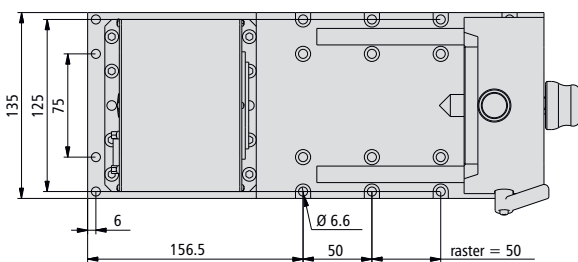
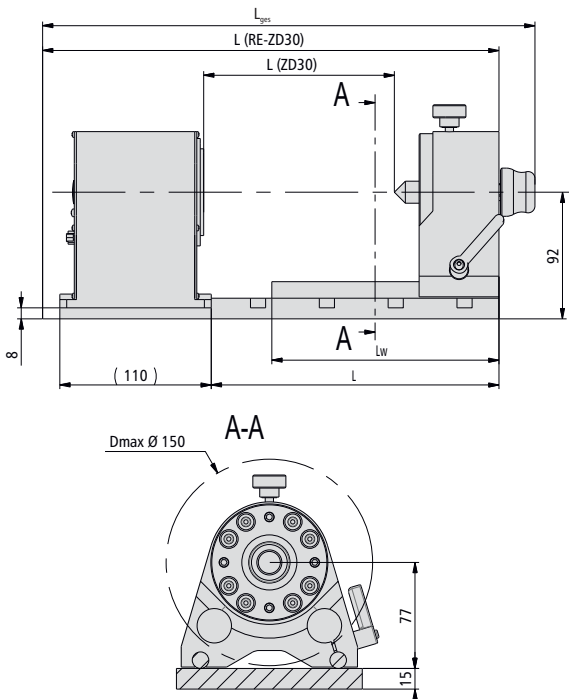

Tailstock unit RE-ZD30 with chuck assembly Ø 65

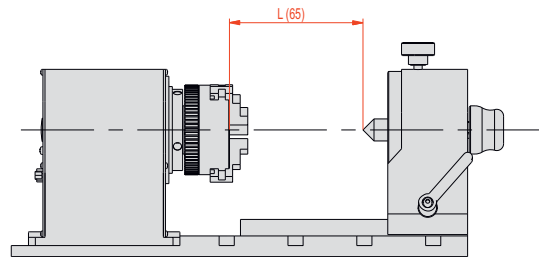

Tailstock unit RE-ZD30 with chuck assembly Ø 80

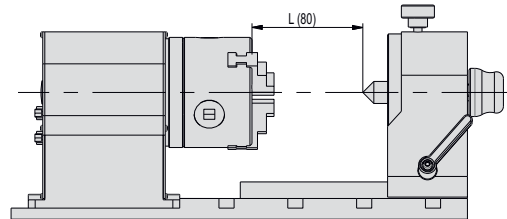

Version	Item-No.	L _{ges}	L	L (ZD30)	L (RE-ZD30)	L _w	L (65)	L (80)
RE-ZD30 200 mm	269100 1060	358	209	138.5	331.5	165	97	80.5
RE-ZD30 300 mm	269100 1070	458	309	238.5	431.5	265	197	180.5
RE-ZD30 400 mm	269100 1080	558	409	338.5	531.5	365	297	280.5
RE-ZD30 500 mm	269100 1090	658	509	438.5	631.5	465	397	380.5

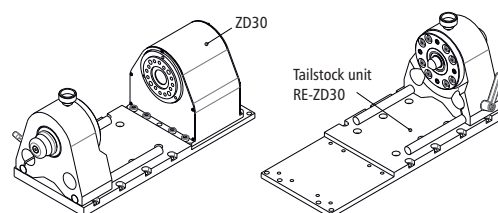

Indexing table

ZR 20

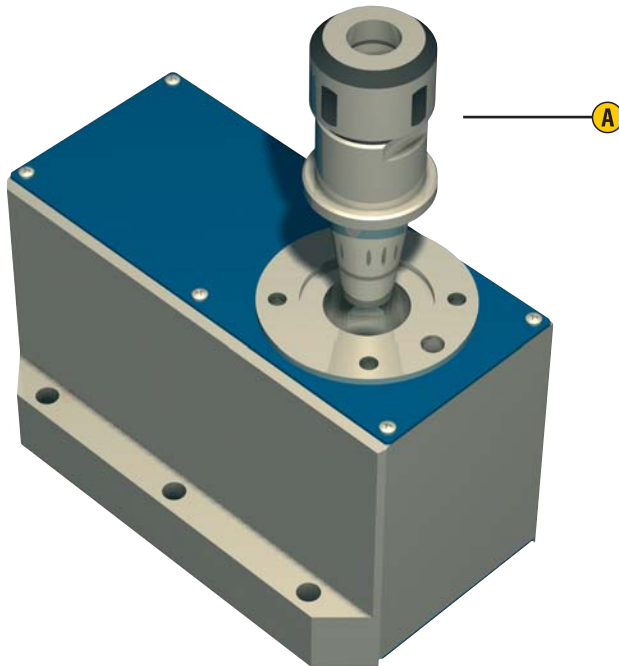

Features

- Low play toothed belt drive with stepper motor
- Reduction 1 : 20
- Shaft with \varnothing 15 mm boring
- Housing flange with inner cone SK 20•
Weight: 2,1 kg

For pin assignment see page **B-108**
For transport loads see page **B-109**

Options:

- CNC controller via Sub D

- A** Collet holder SK 20
(Accessories)

Ordering data

ZR 20 Indexing table
Part no.: **260300 0000**

Technical specification

		stepper motor MS 045 HT *
Reduction ratio		1:20
Abtriebsdrehzahl	[1/min]	0 - 60
Operating torque (0 - 1600 Hz)	[Nm]	8
Rated holding torque (static load)	[Nm]	14
Min. step (positional accuracy)	[arcmin]	3.5
Weight	[kg]	2.1

* Values for half-step operation

Accessories

see rotary tilting unit ZDS 2030

Dimensioned drawing

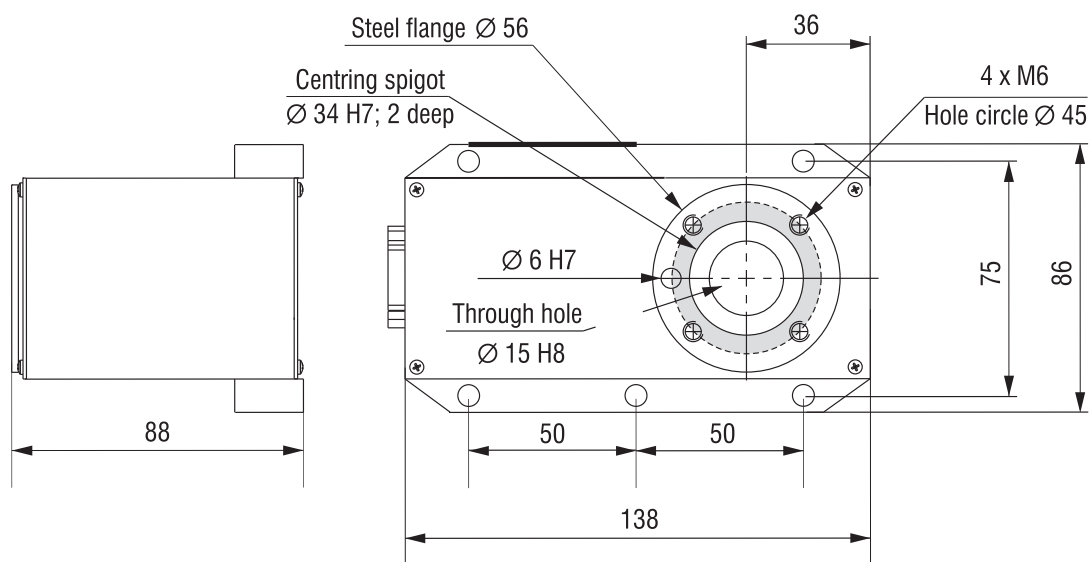

Rotary tilting unit

ZDS 2030

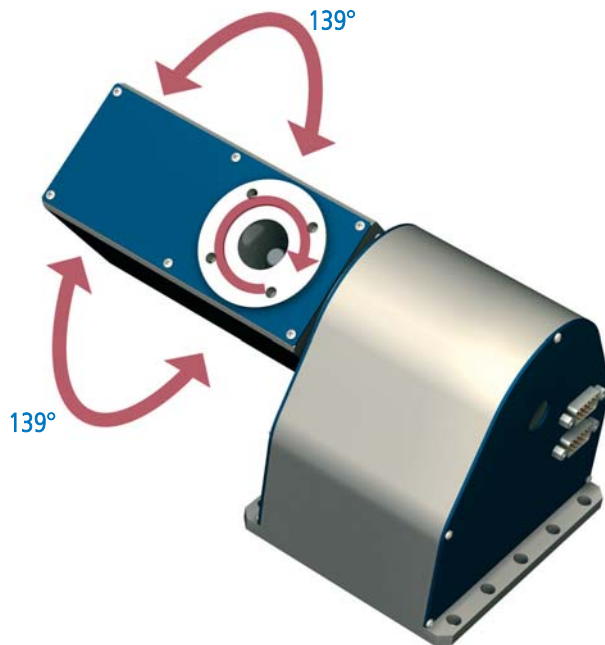

General

The **rotary tilting unit ZDS 2030** can be used as a 4th/5th axis in CNC machines for fine workshops or in the handling area.

It is a combination of ZD 30 and the modified version of ZR 20.

ZDS 2030 enables 5-side machining or free-form surface machining on a conventional 3-axis system of easily machinable materials (e.g. plastic).

The tilting angle is 139° in both directions.

Ordering data

Rotary tilting unit ZDS 2030
Part no.: **265000 0000**

Accessories

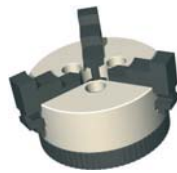

Chuck assembly
3-jaw chuck Ø 65
Part no.: **269060 2065***

* including flange



Clamping ring housing
SK 20 clamping ring housing for tools Ø 3 - 13 mm, with installation ring
Part no.: **239122 9001**
Clamping rings are on page E-38.

Dimensioned drawing

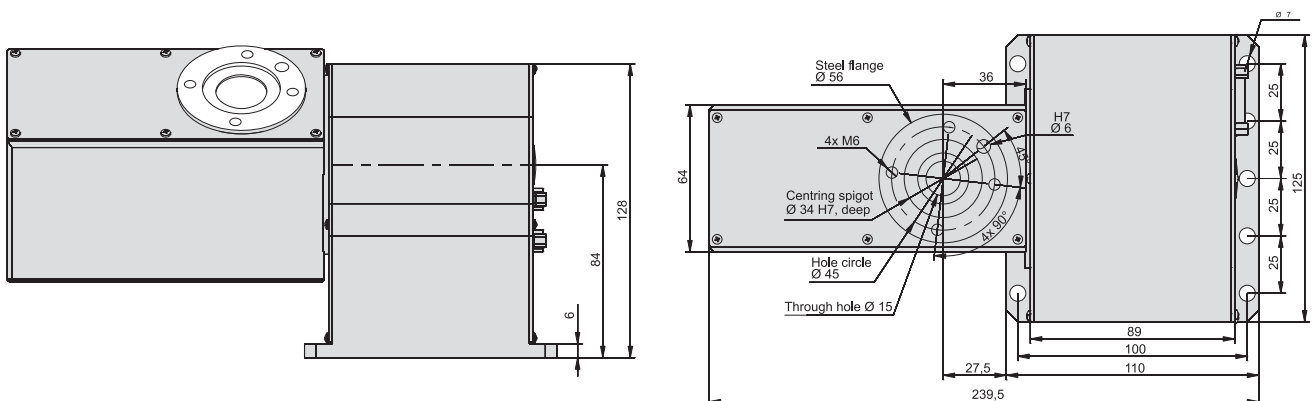

Motor pin assignments

Pin assignment for 12-pin stepper motors

(for RDH, DSH-S)

Motor connection

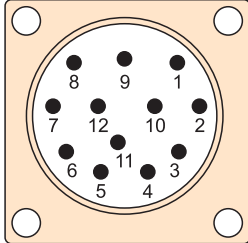

Plug side view of pin insert

M23 12-pin Pin	
1	Motor phase 1A
2	Motor phase 1B
3	Motor phase 2A
4	Motor phase 2B
5	+24V switch
6	+24V brake
7	GND switch
8	GND brake
9	Limit switch 1
10	Limit switch 2
11	---
12	---
Housing - cable shield	

Pin assignment for 9-pin stepper motors

(for RF1, iZD 54, MD 1, ZD 30, ZR 20, ZDS 2030)

Motor connection

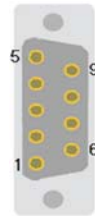

Plug side view of pin insert

Sub-D 9-pin Pin	
1	Motor phase 1A
2	Motor phase 1B
3	Motor phase 2A
4	Motor phase 2B
5	+24V switch
6	+24V brake
7	Limit switch 2
8	GND brake
9	Limit switch 1
Housing - cable shield	

Pin assignment for stepper motors with encoder

(for RDH)

Motor connection

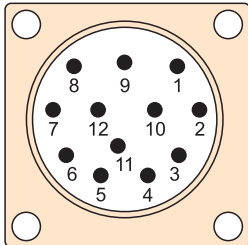

Plug side view of pin insert

M23 12-pin Pin	
1	Motor phase 1A
2	Motor phase 1B
3	Motor phase 2A
4	Motor phase 2B
5	+24V switch
6	+24V brake
7	GND switch
8	GND brake
9	Limit switch 1
10	Limit switch 2
11	---
12	---
Housing - cable shield	

Encoder connection

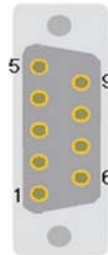

Plug side view of pin insert

Sub-D 9-pin Pin	
1	+5V encoder
2	Encoder track A
3	Encoder track B
4	Encoder track Z
5	---
6	GND encoder
7	Encoder track/A
8	Encoder track/B
9	Encoder track/Z
Housing - cable shield	

Pin assignment for DC servo motors with brushes (BDC)

Motor connection

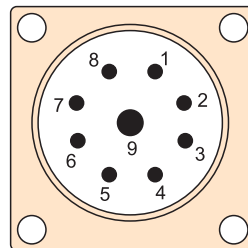

Plug side view of pin insert

M23 9-pol. (8 + 1) pin	
1	Motor phase 1 (V+)
2	Motor phase 1 (V-)
3	Motor phase 1 (V+)*
4	Motor phase 1 (V-)*
5	+24V brake
6	GND brake
7	---
8	---
9	Earthing lead
Housing - cable shield	

* Part motor phase connection over 2 wires.

Encoder connection



Plug side view of pin insert

Sub-D 15-pin Pin	
1	---
2	+5V encoder
3	Encoder track/Z
4	Encoder track/B
5	Encoder track/A
6	+24V switch
7	Limit switch 1
8	GND switch
9	---
10	GND encoder
11	Encoder track Z
12	Encoder track B
13	Encoder track A
14	Reference switch
15	Limit switch 2
Housing - cable shield	

Pin assignment for brushless EC servomotors (BLDC) 48V

Motor connection

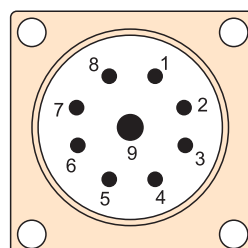

Plug side view of pin insert

M23 9-pol. (8 + 1) pin	
1	Motor phase U
2	Motor phase V
3	Motor phase W
4	---
5	+24V brake
6	GND brake
7	---
8	---
9	Earthing lead
Housing - cable shield	

Encoder connection



Sub-D 15-pin Pin	
1	Hall signal A
2	+5V encoder/Hall
3	Encoder track/Z
4	Encoder track/B
5	Encoder track/A
6	+24V switch
7	Limit switch 1
8	GND switch
9	Hall signal B
10	GND encoder
11	Encoder track Z
12	Encoder track B
13	Encoder track A
14	Hall signal C
15	Limit switch 2
Housing - cable shield	

Turn/tilt/rotation units:

Transport loads, machining forces, feed

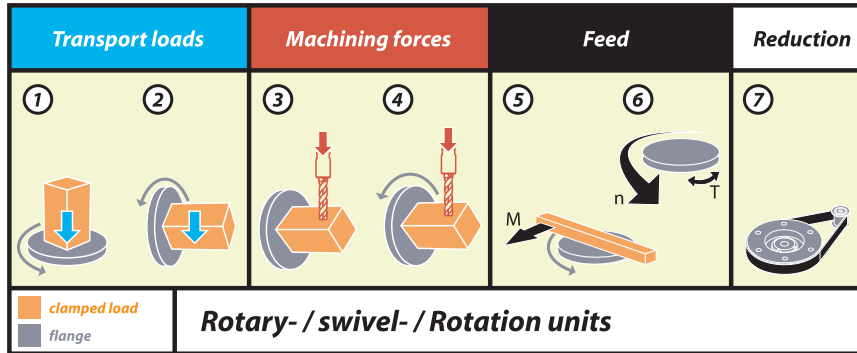

Rotary or tilting units	1*	2*	3	4	5	6	7
RDH-M (step)	100 kg	45 kg	55 Nm	24 Nm	24 Nm	4 rpm	1:51
RDH-M (step)	160 kg	70 kg	108 Nm	45 Nm	45 Nm	2 rpm	1:101
RDH-M (EC-servo, brushless)	110 kg	50 kg	26 Nm	9 Nm	9 Nm	22 rpm	1:51
RDH-M (EC-servo, brushless)	180 kg	80 kg	51 Nm	17 Nm	17 Nm	11 rpm	1:101
RDH-S (step)	30 kg	15 kg	7 Nm	7 Nm	7 Nm	4 rpm	1:51
RDH-S (step)	48 kg	24 kg	11 Nm	11 Nm	11 Nm	2 rpm	1:101
RDH-S (EC-servo, brushless)	30 kg	15 kg	7 Nm	4.6 Nm	4.6 Nm	22 rpm	1:51
RDH-S (EC-servo, brushless)	48 kg	24 kg	11 Nm	4.6 Nm	9.2 Nm	11 rpm	1:101
RDH-S (DC-servo)	25 kg	13 kg	7 Nm	4.6 Nm	4.6 Nm	22 rpm	1:51
RDH-S (DC-servo)	40 kg	20 kg	11 Nm	8.7 Nm	8.7 Nm	11 rpm	1:101
RDH-XS (step)	30 kg	10 kg	5 Nm	5 Nm	5 Nm	24 rpm	1:50
RDH-XS (step)	30 kg	10 kg	7 Nm	7 Nm	7 Nm	12 rpm	1:100
RDH-XS (EC-servo, brushless)	30 kg	10 kg	5 Nm	5 Nm	5 Nm	59 rpm	1:50
RDH-XS (EC-servo, brushless)	30 kg	10 kg	7 Nm	7 Nm	7 Nm	30 rpm	1:100
RDH-XS (DC-servo)	30 kg	10 kg	5 Nm	5 Nm	5 Nm	70 rpm	1:50
RDH-XS (DC-servo)	30 kg	10 kg	7 Nm	7 Nm	7 Nm	35 rpm	1:100
RF 1 (step)	60 kg	30 kg	37 Nm	17.5 Nm	17.5 Nm	50 rpm	1:24
RF 1 (step)	100 kg	50 kg	75 Nm	38 Nm	38 Nm	23 rpm	1:52
RF 1 (step)	150 kg	75 kg	75 Nm	75 Nm	75 Nm	12 rpm	1:100
RF 1 (DC servo/EC servo)	70 kg	35 kg	7 / 12 Nm	6 / 10 Nm	6 / 10 Nm	125 rpm	1:24
RF 1 (DC servo/EC servo)	110 kg	55 kg	16 / 26 Nm	13 / 22 Nm	13 / 22 Nm	58 rpm	1:52
RF 1 (DC servo/EC servo)	160 kg	80 kg	30 / 50 Nm	25 / 42 Nm	25 / 42 Nm	30 rpm	1:100
MD 1 (step)	5 kg	2.5 kg	14 Nm	8 Nm	8 Nm	60 rpm	1:20
MD 1 (DC servo)	6 kg	3 kg	3.9 Nm	3 Nm	3 Nm	175 rpm	1:20
MD 1 (EC servo, brushless)	6 kg	3 kg	4 Nm	3.2 Nm	3.2 Nm	150 rpm	1:20
ZR 20 (step)	10 kg	5 kg	14 Nm	8 Nm	8 Nm	60 rpm	1:20
ZD 30 (step)	14 kg	8 kg	20 Nm	12 Nm	12 Nm	40 rpm	1:30

*) Guideline values will vary according to application !!

electron

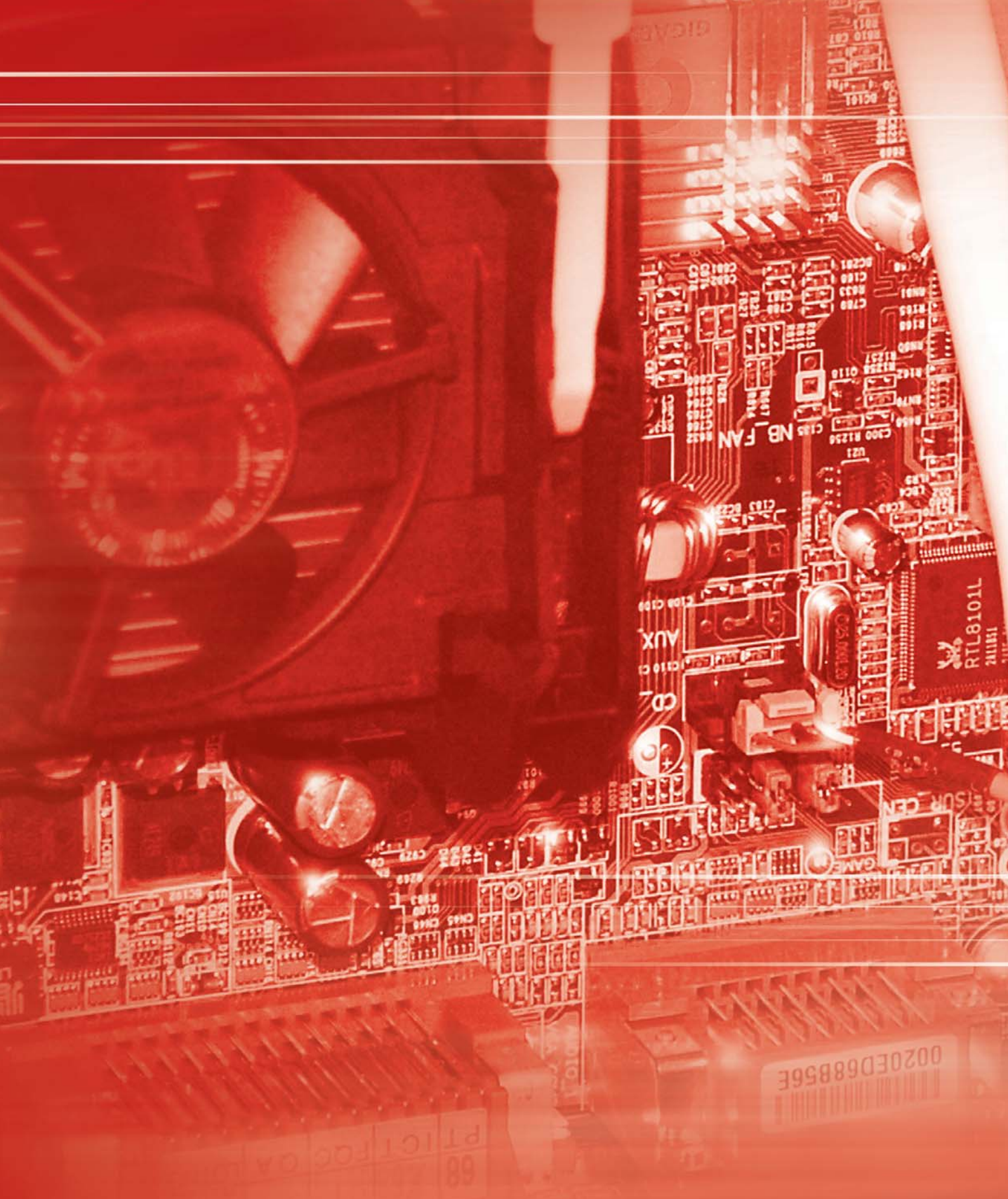

ics

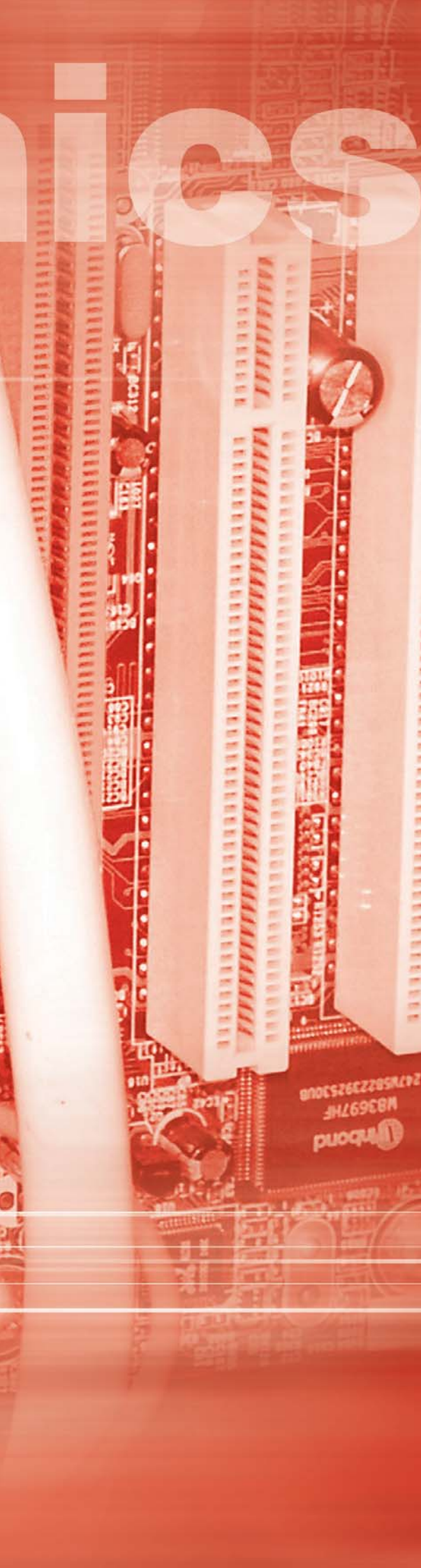

ELECTRONICS

Motors	C-4
Sensors	C-12
Controllers	C-14

Overview

Two-phase stepper motors

C-4



MS 135HT-2
MS 200HT-2



MS 300HT-2
MS 600HT-2
MS 900HT-2

EC servo motors

brushless

C-6



EC 42



EC 60



EC 86

Linear motors

C-10



iLM 25



iLM 50

Magnetic length measuring system

C-12



iMS 10

CNC control units

C-14



iOP 19-TFT
iOP 19-CPU

Drive modules

for 2-phase step motors

C-15



MD 24/28

Overview

Drive controllers

C-16



PC controller

C-18



iPC 25

CAN PCI board

C-19



iCC 10 /20

CAN controller components

C-20



CAN I-O
modules

Step controller

Single axis controller

C-21



IT 116 Flash

Step controller

Multiple axis controller

C-22



iMC-S8

Servo controller

Single axis controller

C-23



MC 1-10
MC 1-20
MC 1-40

Servo controller

Multiple axis controller

C-24



iCU-DC / iCU-EC



iPU-DC / iPU-EC

CAN-CNC controller

Overview

C-26

Two-phase stepper motors

MS 135/200 HT-2



Two-phase stepper motor MS 135 HT - 2

Features

- Step angle 1.8°, higher resolution through microstep mode
- Very high torque through rare earth magnets
- Optimised for use with position controllers
- Optimum torque/size ratio
- Smaller step angle errors, non-cumulative
- IP43 protection class
- **Optional:**
 - MD 24 drive module
 - Brake (MS 200 HT)
 - Second shaft end (MS 200 HT)

General

Two-phase stepper motors behave similarly to synchronous motors. They are easy to control and are characterised by very long working life and reliability, at a favourable price. This results in a wide range of applications. Two-phase stepper motors in the MS range are of the high torque type. A particularly high torque is achieved by the use of rare earth magnets.

Technical specification

Description	Holding moment bipolar Nm	Winding current per phase A	Winding voltage per phase V	Winding inductance per phase mH	Weight kg	Length (without shaft) mm	Part no.
MS 135 HT-2	1.1	3.0	2.4	2.4	0.7	56	470551
MS 200 HT-2	1.8	3.0	3.0	3.5	1.0	76	470581
MS 200 HT-2 (2nd shaft end)	1.8	3.0	3.0	3.5	1.1	76	470581 0100
MS 200 HT-2 (brake)	1.8	3.0	3.0	3.5	1.8	76	470581 0200

Wiring diagram

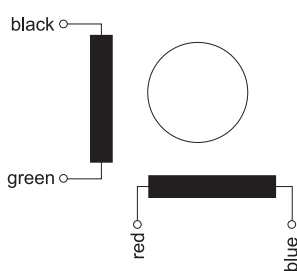

Dimensioned drawing

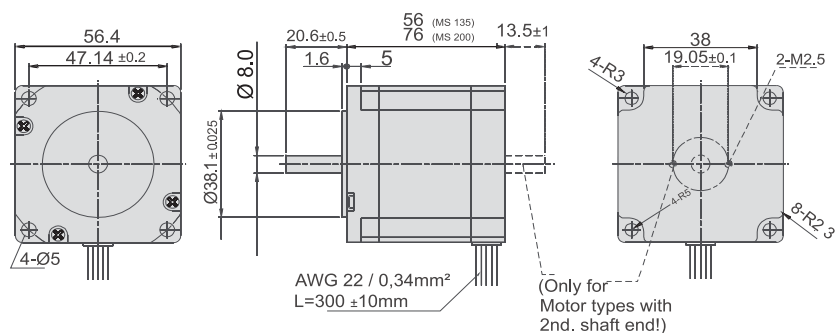

Torque curves

MS 135 HT

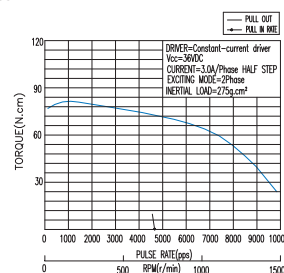

MS 200 HT

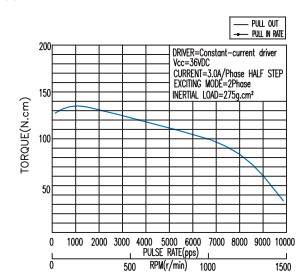

Technical specifications subject to change.

Two-phase stepper motors

MS 300/600/900 HT-2

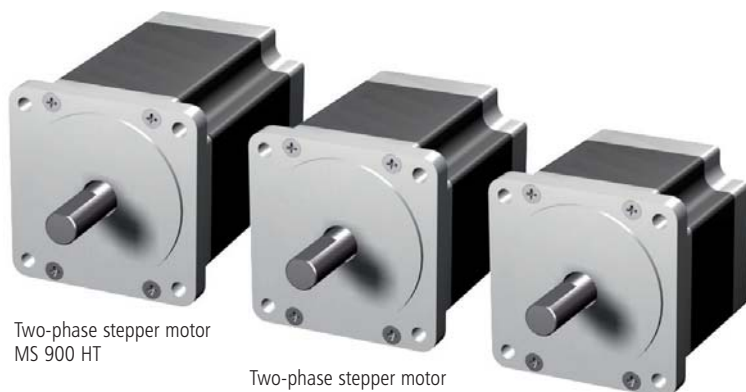

Two-phase stepper motor
MS 900 HT

Two-phase stepper motor
MS 600 HT

Two-phase stepper motor
MS 300 HT

Features

- Step angle 1.8°, higher resolution through microstep mode
- Very high torque through rare earth magnets
- Optimised for use with position controllers
- Optimum torque/size ratio
- Smaller step angle errors, non-cumulative
- IP43 protection class
- **Optional:**
 - MD 28 drive module
 - Brake (MS 300 HT)

General

Two-phase stepper motors behave similarly to synchronous motors. They are easy to control and are characterised by very long working life and reliability, at a favourable price. This results in a wide range of applications. Two-phase stepper motors in the MS range are of the high torque type. A particularly high torque is achieved by the use of rare earth magnets.

Technical specification

Description	Holding torque Bipolar Nm	Winding current per phase parallel/series A	Winding voltage per phase parallel/series V	Winding inductance per phase mH	Weight kg	Length (without shaft) mm	Part no.
MS 300 HT - 2	3.11	5.6 / 2.8	1.68 / 3.38	1.6	2.0	63	470821
MS 300 HT - 2 (brake)	3.11	5.6 / 2.8	1.68 / 3.38	1.6	2.75	104	470821 0200
MS 600 HT - 2	6.80	7.0 / 3.5	2.28 / 4.55	2.4	3.0	98	470851
MS 900 HT - 2	9.00	6.3 / 3.1	2.84 / 5.67	4.2	4.5	126	470881

Wiring diagram

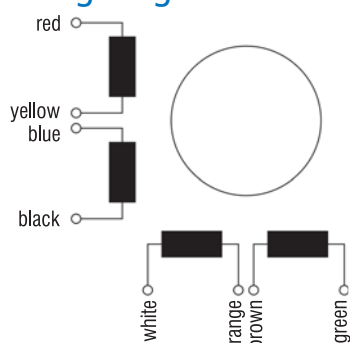

Dimensioned drawing

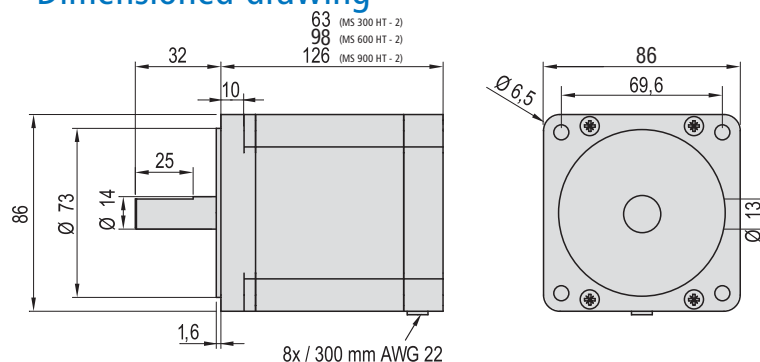

Torque curves

MS 300 HT

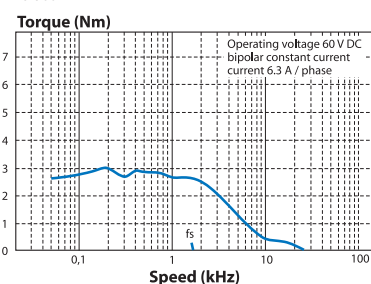

MS 600 HT

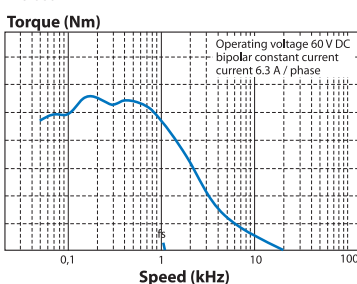

MS 900 HT

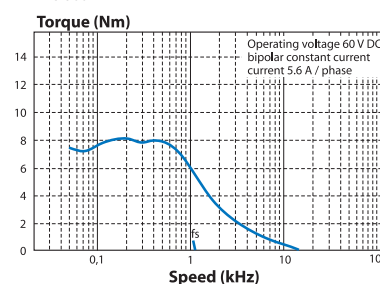

Technical specifications subject to change.

Servo motors

with brushless drive

EC 42



Features

- Electronically commutated 3-phase-servo motor
- Brushless drive
- Compact configuration
- Incremental encoder with 1000 increments/turn, RS422
- Hall sensors
- Areas of application: positional control, speed control

Technical specification

Part no.	Description	Rated output W	Nominal voltage V DC	Current A	Number of poles	Rated speed rpm	torque at rated speed Nm	Peak torque Nm	Length L mm	Weight kg
474062 0048	EC 42	62	48	1.75	8	3000	0.2	0.6	88	0.55

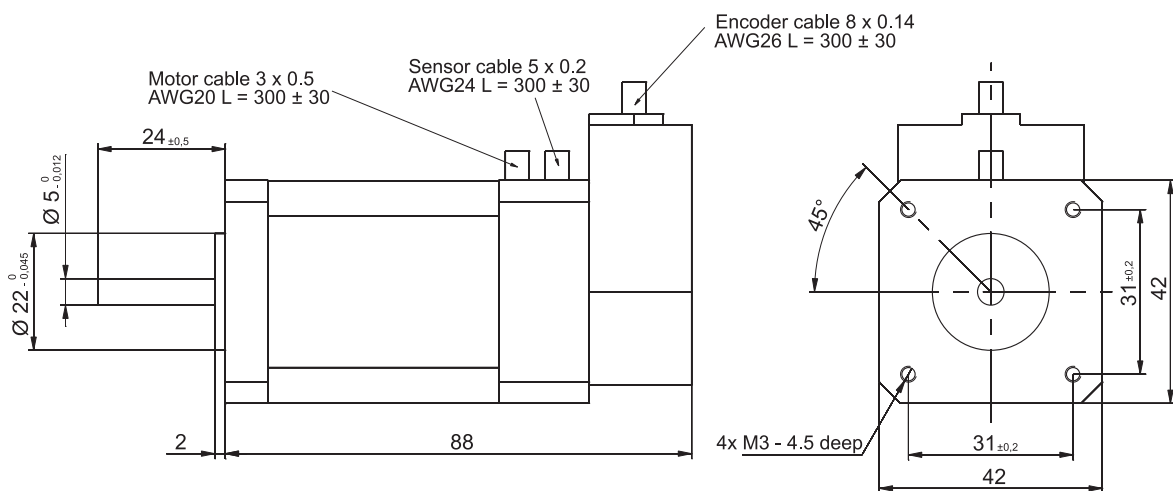

Wire colours

Motor cable

Signal	Colour
Motor U	yellow
Motor V	blue
Motor W	green

Hall cable

Signal	Colour
Hall A	yellow
Hall B	green
Hall C	blue
Vcc +5 V	red
Gnd	black

Encoder cable

Signal	Colour
Encoder A	blue
Encoder /A	blue/black
Encoder B	green
Encoder /B	green/black
Encoder Z	yellow
Encoder /Z	yellow/black
Vcc +5 V	red
Gnd	black

Technical specifications subject to change.

Servomotors

with brushless drive

EC 60



Features

- Electronically commutated 3-phase servomotor
- Brushless drive
- High output performance concurrently with compact build
- Incremental encoder with 1000 increments/turn, RS422
- Hall sensors
- IP44 protection class
- Uses: Positioning and speed control
- Connection via circular plug
- Option: Brake

General

Brushless EC motors are designed as electronically switched 3-phase synchronous motors. Compared with brush drives, these motors have an even longer working life, because they are subjected to less wear. Moreover, in this case, high power density and dynamic response relative to size must be emphasized. These motors are used in many automation technology areas and in CNC machines.

Technical specification

Part no.	Description	Rated output W	Rated voltage V DC	Current A	Number of poles	Rated speed rpm.	Torque at rated speed Nm	Peak torque Nm	Length L (mm)	Weight kg
474156 0048	EC 60S	156	48	6.9	8	3,000	0.5	1.75	73	1.25
474156 1048	EC 60S with brake	156	48	6.9	8	3,000	0.5	1.75	73	2.0
474235 0048	EC 60L	235	48	10.5	8	3,000	0.75	2.25	94	1.6
474235 1048	EC 60L with brake	235	48	10.5	8	3,000	0.75	2.25	94	2.35
474235 0310	EC 60L	235	310	1.6	8	3,000	0.75	2.25	94	1.6
474235 1310	EC 60L with brake	235	310	1.6	8	3,000	0.75	2.25	94	2.35

Dimensioned drawings

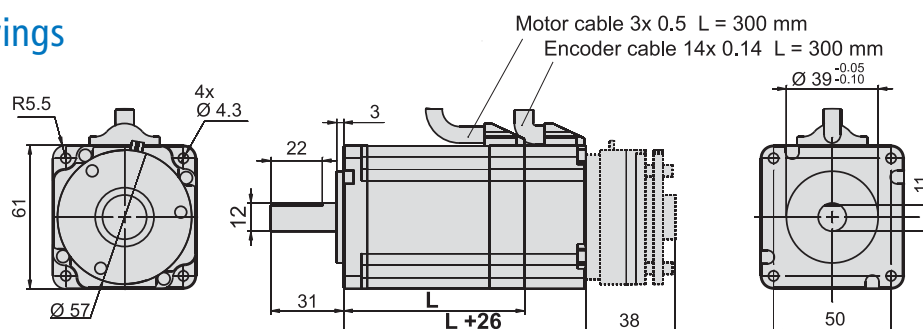

Wire colours/ Pin assignments

Motor cable

Signal	Colour
Motor U	yellow
Motor V	blue
Motor W	green
PE	green/yellow

Encoder cable

Pin	Signal	Colour
1	Shield	Shield
2	Gnd	black
3	Vcc +5 V	red
4	Encoder B	grey
5	Encoder /B	grey/black
6	Encoder A	brown
7	Encoder /A	brown/black
8	Encoder Z	orange
9	Encoder /Z	orange/black
10	Hall A	yellow
11	Hall B	white
12	Hall C	green

Encoder cable plug connector:
12-pole female connector strip, type JST PHR-12

Servomotors

with brushless drive

EC 86



Features

- Electronically commutated 3-phase servomotor
- Brushless drive
- High output performance concurrently with compact build
- Incremental encoder with 1000 increments/turn, RS422
- Hall sensors
- IP44 protection class
- Uses: Positioning and speed control
- Connection via circular plug
- Option: Brake

General

Brushless EC motors are designed as electronically switched 3-phase synchronous motors. Compared with brush drives, these motors have an even longer working life, because they are subjected to less wear. Moreover, in this case, high power density and dynamic response relative to size must be emphasized. These motors are used in many automation technology areas and in CNC machines.

Technical specification

Part no.	Description	Rated output W	Rated voltage V DC	Current A	Number of poles	Rated speed rpm.	Torque at rated speed Nm	Peak torque Nm	Length L mm	Weight kg
474440 0310	EC 86S	440	310	3.4	8	3,000	1.4	5.0	100	2.6
474660 0310	EC 86L	660	310	3.6	8	3,000	2.1	7.4	125	4

Dimensioned drawings

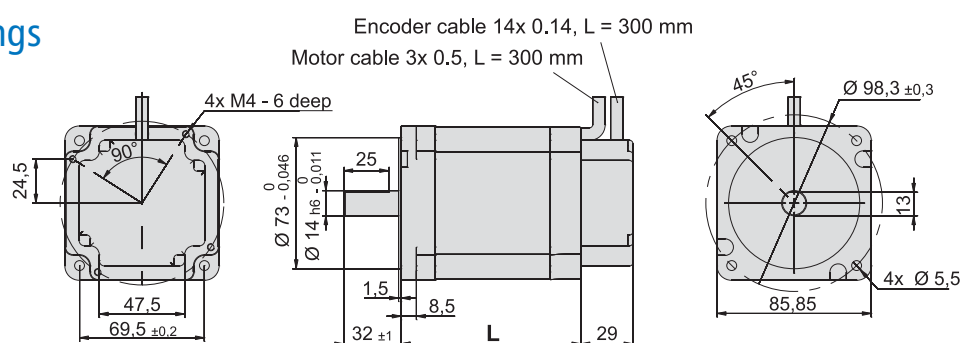

Wire colours/ Pin assignments

Motor cable

Signal	Colour
Motor U	yellow
Motor V	blue
Motor W	green
PE	green/yellow

Encoder cable

Pin	Signal	Colour
1	Shield	Shield
2	Gnd	black
3	Vcc +5 V	red
4	Encoder B	grey
5	Encoder /B	grey/black
6	Encoder A	brown
7	Encoder /A	brown/black
8	Encoder Z	orange
9	Encoder /Z	orange/black
10	Hall A	yellow
11	Hall B	white
12	Hall C	green

Encoder cable plug connector:
12-pole female connector strip, type JST PHR-12

Technical specifications subject to change.

Space for your notes

Linear motors

LS winding package with MS magnetic rail

iLM series

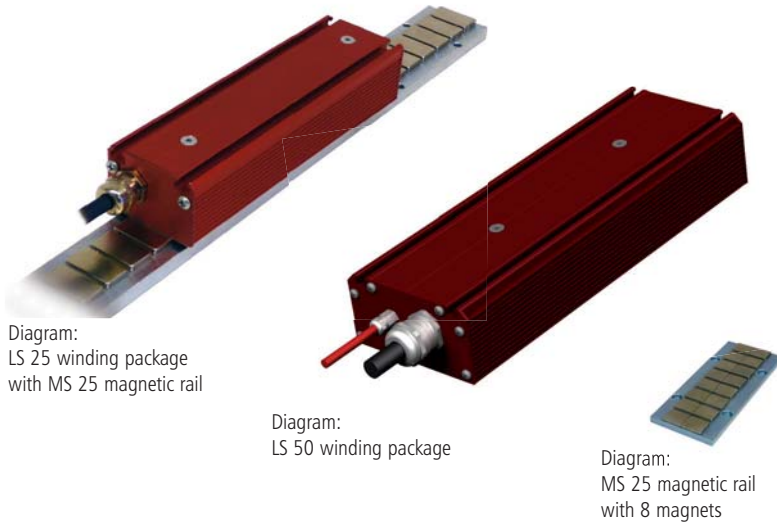

Diagram:
LS 25 winding package
with MS 25 magnetic rail

Diagram:
LS 50 winding package

Diagram:
MS 25 magnetic rail
with 8 magnets

Features

- Ready-for-installation systems comprising primary part (LS winding package) and secondary part (MS magnetic rail)
- Compact build
- High acceleration
- High speed and dynamic response
- High efficiency
- Free from wear
- Custom motor length
- Secondary part (MS magnetic rail): Elements of any length, depending on their carrier system, can be arranged in rows
- Controllable with standard servo converters

Optional:

- iMD 40 drive controller (only in conjunction with Hall board)
- Magnetic length measurement system
- Linear guides

General

Linear motors in the iLM series are linear 3-phase servomotors of various sizes and any length at a favourable price/performance ratio. The optionally integrated Hall sensors provide the positional information for switching the motor. There is a PTC temperature sensor in the primary component to protect the motor. The electrical connections (Hall, windings and temperature sensor) are made via permanently installed cable. Owing to the direct power transfer, there is no need for any mechanical transfer elements, such as spindles and toothed belts which completely eliminates friction and play. This means that higher speeds and dynamic responses can be achieved. The resultant lower clocking times reduce production costs and increase productivity. Because there are no mechanical elements in the drive itself, noise, wear and the resultant maintenance costs are minimised. In comparison with other linear drives, drives with linear motors are more accurate, faster, free from play (without return play) and more robust.

Ordering information

Winding package

486 0X2 000X

Coil package

0 = LS 25

1 = LS 50

Number of coils

1 = 3 coils

2 = 6 coils

3 = 9 coils

4 = 12 coils

Magnetic rails

MS 25 magnetic rail with 8 magnets (L×W×H approx.124/45/11mm)

Part-no.: **486100 01241**

MS 25 magnetic rail with 32 magnets (L×W×H approx.496/45/11 mm)

Part-no.: **486100 04961**

MS 50 magnetic rail with 8 magnets (L×W×H approx. 200/80/11 mm)

Part-no.: **486110 0200**

MS 50 magnetic rail with 16 magnets (L×W×H approx. 400/80/11 mm)

Part-no.: **486110 0400**

MS 50 magnetic rail with 32 magnets (L×W×H approx. 800/80/11 mm)

Part-no.: **486110 0800**

LS 25 coil package with 6 coils and Hall boards
 + 2× MS 25 magnetic rails with 32 magnets
 + iMD 40 drive controller
 + iMS-I magnetic length measuring system (5 μm resolution)

Part-no.: **486001 0002**

Part-no.: **486100 0496**

Part-no.: **314040**

Part-no.: **390255 4412**

Technical specifications subject to change.

Linear motors

LS winding package with MS magnetic rail

iLM series

Technical specification

	Intermediate circuit voltage [V] **	Number of coils	Rated current [A]	Peak current [A]	magnetic period [mm]	max. feed force [N]	max. tensile force [N]*	Rated speed [m/s] at rated current
LS 25/6 coils	320	6	2.6	6.5	31	170	500	3.0
LS 25/12 coils	320	12	2.6	6.5	31	340	1,000	2.0
LS 50/6 coils	560	6	6.0	15.0	50.4	675	1,995	5.0
LS 50/12 coils	560	12	6.0	15.0	50.4	1,350	3,990	2.5

** Higher intermediate circuit voltage to order.

* Applicable for a working air gap of 0.8 mm.

Dimensioned drawings

iLM 25 linear motor

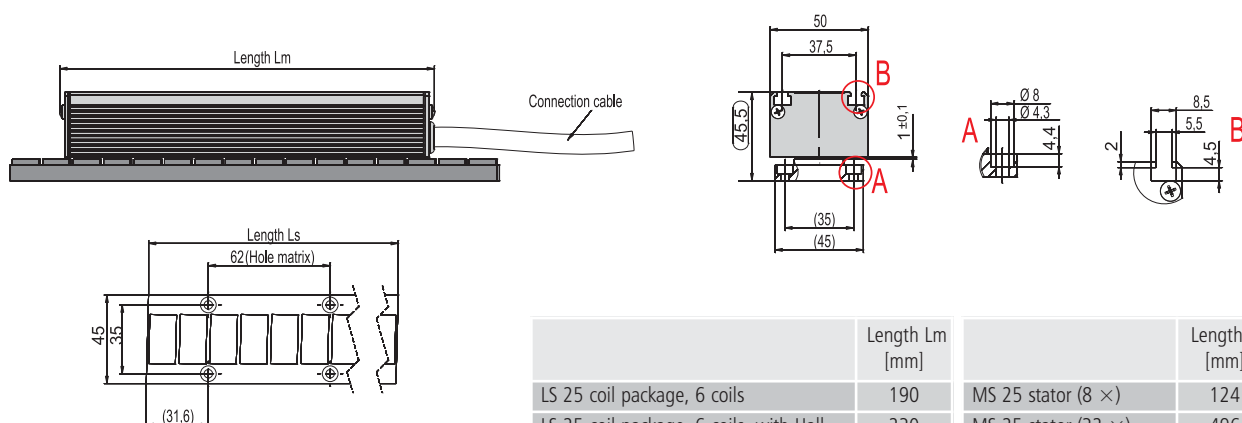

iLM 50 linear motor

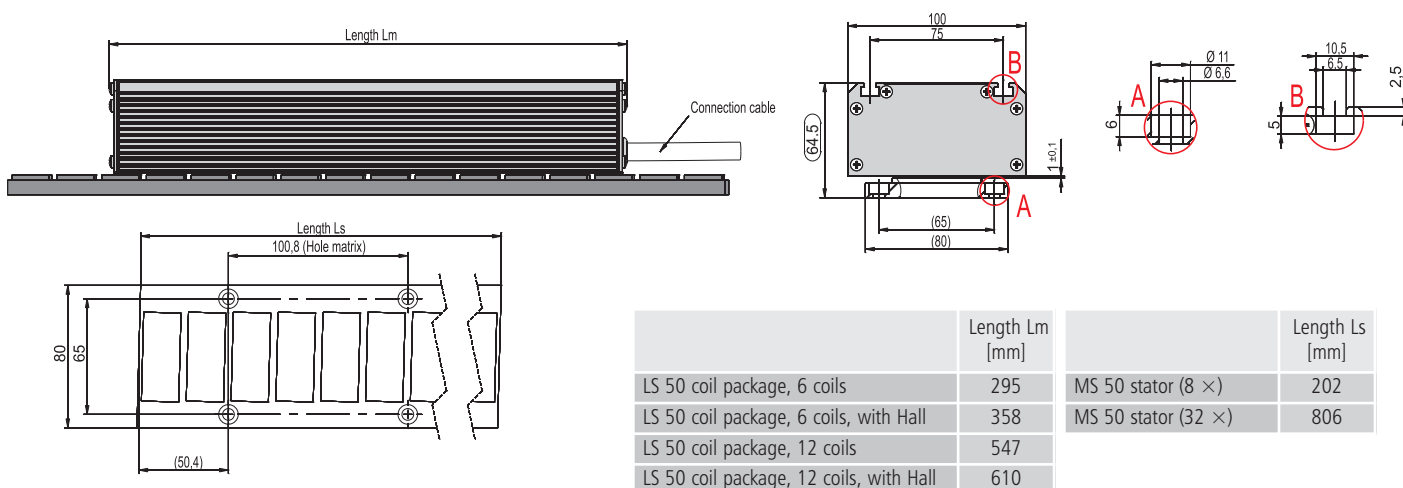

Technical specifications subject to change.

iMS magnetic length measuring system

Detailed
information

under
www.isel-germany.de



Diagram:
iMS magnetic length measuring system

Features

- Measuring head with sensor in stable casing
- Reliable, robust, good value
- 2 channels, A and B, difference mode incremental RS 422 or difference mode analogue 1VSS
- Incremental/digital resolution (see table)
- Repeatability = ± 1 increment
- Magnetic tape on self-adhesive, stainless steel bearer tape

optional:

- Reference pulse

General

The iMS contactless magnetic measuring system relies on scanning a magnetically coded measuring tape by means of a magnetically sensitive sensor and is suitable for detection of both linear and radial positions. A decisive advantage compared with significantly more expensive optical systems is provided by its insensitivity to contamination caused by liquids, greases and dust. Our length measuring system is therefore a cost-effective alternative to other systems on the market.

Available sensor interfaces for further processing in the peripherals are, optionally, a pulse sensor with incremental RS422 AB output (Z optional) and a SIN/COS/(Z optional) sensor with voltage amplitude 1Vss.

Ordering data

iMS-I magnetic length measuring system
in casing
Resolution $5\mu\text{m}$, edge interval $0.55\mu\text{s}$,
Processing speed 5.25 m/s
Part no.: **390255 5512C2**

Magnetic tape on self-adhesive stainless steel bearer tape (2 mm pole pitch, 10 mm wide, 1.3 mm thick)
Part no.: **563150**

Dimensioned drawing

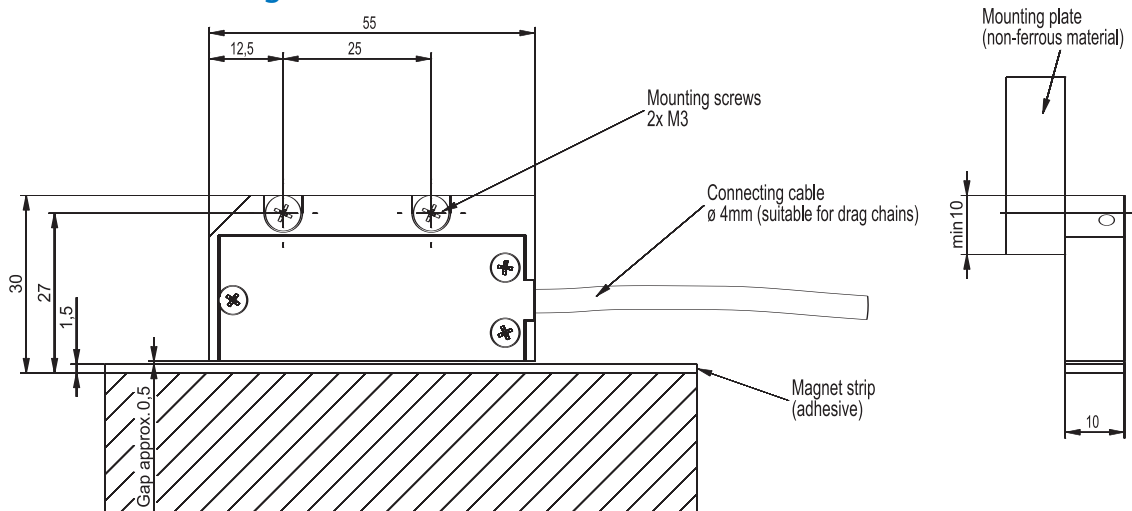

Technical specifications subject to change.

iMS magnetic length measuring system

Technical specification

Sensor

Mechanical specification	
Casing	Aluminium
Weight	approx. 70g
Sensor lead	PUR
Cable bending radius	>10 mm, first bend > 10 mm from sensor casing
Electronic data	
Supply voltage	4.9V - 5.1V (optional: 7V - 15V)
Current drain	< 100 mA on no load
Output signals	Standard RS422 A, /A, B, /B optional reference Z, /Z Option: SIN/ COS 1Vss +20%, -40%, Z und /Z right sign
Termination	Terminating resistor = 120 Ohm between corresponding output signals, e.g. A - /A, at receiver
Sensor distance - magnetic tape	0.4 - 0.7 mm
Sensor resolution incremental	1 μm , 2.5 μm , 5 μm , 10 μm , 20 μm
Pulse interval	0.25 μs , 0.55 ns, 1 μs , 2 μs , 4 μs , 8 μs
maximum speed	< 10 m/s, higher on request
Repeat accuracy	Incremental resolution ± 1 increment, plus errors due to angular tilting in the 3 sensor axes
accuracy	Measurement error 20 μm , plus errors due to angular tilting in the 3 sensor axes
Reference sequence	optional: NSN (special order)
Ambient conditions	
Operating temperature	-5°C to 80°C
Storage temperature	-20°C to 100°C
Air humidity (only sensor)	100%, dewing allowed

Normal measurement - magnetic tape

operating temperature	-5°C to 80°C
Material	High quality stainless steel, coding bearer elastomer, self-adhesive
Thickness	1.3 mm \pm 0.15 mm + bonding layer 0.13 mm, optional: 0.1 mm stainless steel tape + 0.2 mm bonding layer
Width	10 mm
Length	up to 50m on roll
Pole pitch/PITCH	2 mm, i.e. north pole = 2 mm, south pole = 2 mm magnetic period = 4 mm
Number of tracks	Single track, 10 mm wide Option: signal track 5 mm, reference track periodically 5 mm
accuracy	\pm 0.04mm/m, at 20°C
Coefficient of expansion	17E-6 m/Kelvin
Ambient conditions	
with no or minimum effect on the measurement norm	Chemical resistance to contamination with motor oil, gearbox oil, ATF, hydraulic oil, kerosene, antifreeze, Clorox disinfectant, turpentine, water, brine. The materials listed have no or little effect on the long term stability of the measurement standard; this depends, among other things, on the concentration, the temperature and the time of the contamination. Please check your own case.
little/average effect on the measurement standard	Jet petrol, carburettor fuels, heptanes, alcohols
strong effect on the measurement standard	Aromatic hydrocarbons, ketones, inorganic acids

CNC control units

iOP-19-TFT / iOP-19-CPU



General

The CNC control units iOP-19 are a revised version of the previous isel control panels iBP. All experiences have been incorporated into the new development of the iOP-19. They have an integrated 19" touch screen monitor, a silicone keyboard as well as a control panel with stainless steel buttons and emergency stop switch. A PC can be connected and operated via the lead-out standard connecting cables. The iOP-19-CPU has an isel CAN.

Dimensioned drawings

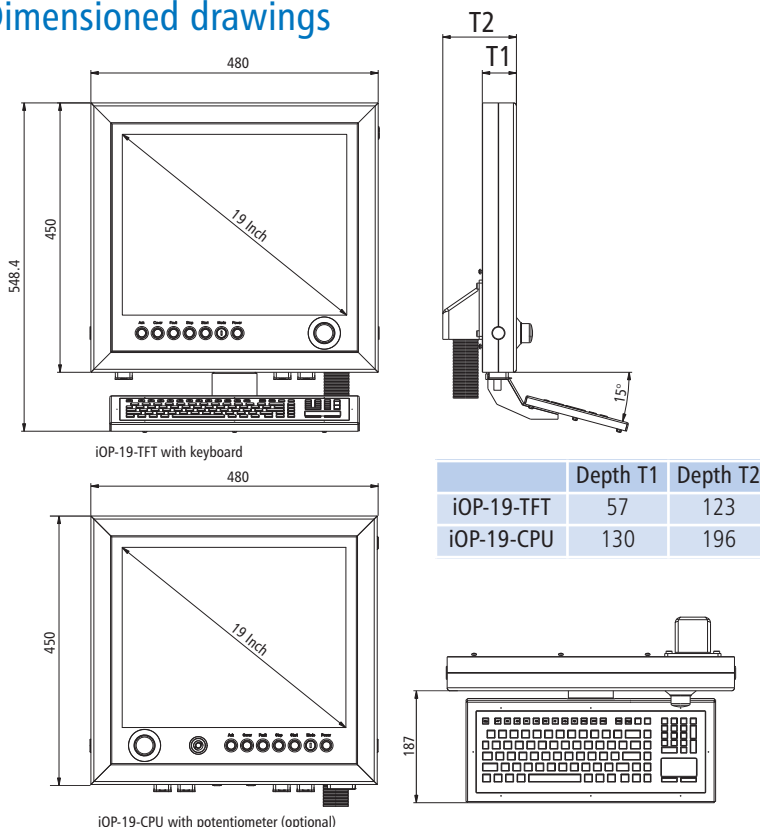

Common features

- robust aluminium housing (standard color: RAL 3011 / red)
- 19" touch screen display
- high-quality silicon keyboard (protection class: IP68)
 - in German and English
 - 105 keys, with touchpad
- easy mounting option for keyboard
- user-friendly approach via high-adjustable arm
- easy mounting via VESA mounting 100/100
- 3 USB ports

Features iOP-19-TFT

- Protection class IP 50
- Dimensions (without keyboard): W 480 x D 123 x H 450 mm
- Weight: approx. 15kg

Features iOP-19-CPU

- Protection class IP 40 and IP 50
- Motherboard 64 bit / CPU IntelCore I3
- additional a network connection (LAN)
- Dimensions (without keyboard): W 480 x D 196 x H 450 mm
- Weight: approx. 16kg

Options

- foot
- simple keyboard and mouse tray
- Two-hand operation
- RAL 9005 (black) or graphite hammer
- Potentiometer for Override (iOP-19-CPU)

Ordering Data

Control panel **iOP-19-TFT**, RAL 3011 (red)
Part-no.: **371100 1000**

Control panel **iOP-19-CPU**, RAL 3011 (red)
Part-no.: **371101 1000**

German keyboard, RAL 3011 (red)
Part-no.: **371200 0001**

English keyboard, RAL 3011 (red)
Part-no.: **371200 0002**

Swivel arm for profile PS 50
Part-no.: **371050 2020**

Swivel arm for profile PS 80
Part-no.: **371050 2040**

Swivel arm for profile 100
Part-no.: **371050 2050**

Swivel arm for profile 125
Part-no.: **371050 2060**

Swivel arm for profile PS 140
Part-no.: **371050 2070**

Swivel arm for profile PV 150
Part-no.: **371050 2080**

Technical specifications subject to change.

Drive modules MD 24/28

for 2-phase step motors



Features

- High performance, low noise
- Power supply up to 50 V DC (80 V DC)*
- Output current up to 4.2 A (7.8 A)*
- Automatic current reduction
- Suitable for 2-phase and 4-phase stepper motors
- Clock / direction interface
- Input frequency for clock input up to 300 KHz
- 15 (14)* selectable resolutions up to 25,600 steps/rev (51,200 steps/rev)*
- Opto-isolated, TTL-compatible inputs
- Protection against short-circuit, overvoltage and overcurrent*

* MD 28

General

The step motor drive modules MD24/MD28 are powerful final stages for 2-phase and 4-phase step motors. The modules are micro-step capable and thus allow very quiet running of the connected motors. Due to its particular chopper technology for the motor current, identical motors can deliver higher speeds and torques than conventional, comparable drive modules. The clocking/direction interface also allows simple connection to various motion controllers or a PLC.

Technical specification

Parameter	Unit	MD 24			MD 28		
		Min.	Typical	Max.	Min.	Typical	Max.
Output current	A	1	-	4.2 (3.0 A rms)	2.8	-	7.8 (5.6 A rms)
Mains voltage	VDC	20	36	50	24	68	80
Current logic signals	mA	7	10	16	7	10	16
Clocking input frequency	kHz	0	-	300	0	-	300
Insulation resistance	MΩ	500			500		
Part no.		316303			316304		

Dimensioned drawings

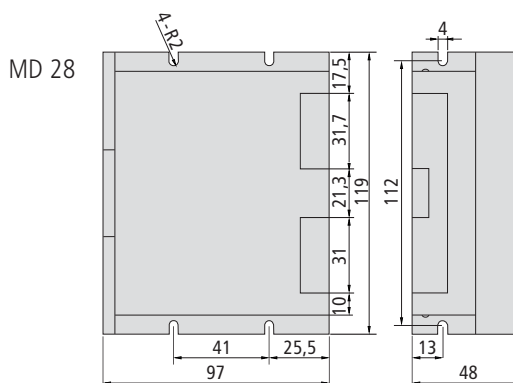
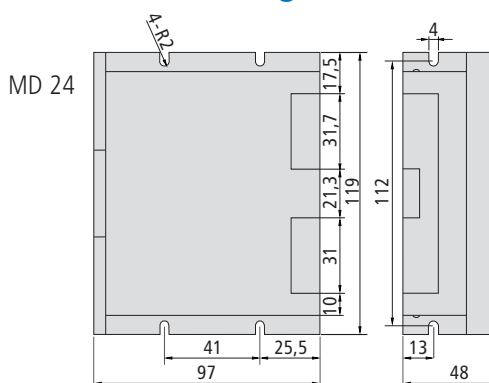

Technical specifications subject to change.

Drive controller

for stepper and servo motors

iMD 10/20/40



iMD 10



iMD 20



iMD 40

General

The **iMD10/20** series of drive controllers are economical final stages for DC motors (iMD10) and EC servomotors (iMD20).

The fully digital **iMD40** drive controller is an economical final stage, powered directly from the mains, for EC servomotors (synchronous motors, such as linear or torque motors) up to 2 kW.

Typical applications are CNC machines and automation systems. The final stage casings are optimised for cabinet installation. The extensive configuration options allow flexible adaptation to a wide range of applications and all required settings can be made with a user-friendly commissioning software package.

There are various user interfaces available for integration with proprietary applications. Here, the CAN open interface must be emphasized. In addition to synchronous point-to-point positioning (S-PTP) and speed control, track control (CP -Continuous Path) and synchronised multiple axis applications are feasible using the implemented CANopen protocol DS402. Additional interfaces include a $\pm 10V$ interface (nominal speed) and a RS232 interface.

Short controller cycle times (current, speed, position controller) ensure optimum performance for highly dynamic drives. The drive controllers are suitable both for rotary drives and for the corresponding linear direct drives and torque motors (iMD20 and iMD40). A redundant rest monitoring system has been integrated in the drive controller. It reduces work by the controller in external assemblies to a minimum and allows for convenient operation or use of the machine.

Drive controller

for stepper and servo motors

iMD 10/20/40

Technical specification

Features	iMD 10	iMD 20	iMD 40
Motor type	Brush servomotors (DC)	Brushless servomotors (EC)	Brushless servomotors (EC)
Power supply	40-95 V DC		230V AC, mains, single phase
Motor current	Constant current 12 A, peak current 25 A		Constant current 6.5 A Peak current 8 A
CAN bus interface	CANopen DS301 V4.0 and DS402 V1.0 der CiA (CAN in automation)		CANopen DS301 V4.0 and DS402 V1.0 of CiA (CAN in automation)
RS-232 interface (asynchronous, 19.2 or 57.6 kbits/s).	For commissioning (DcSetup.exe) or e.g. PLC connection; effective data transfer protocol	For commissioning (AcSetup.exe) or e.g. PLC connection; effective data transfer protocol	For commissioning (AcSetup.exe) or, e.g. PLC connection; effective data transfer protocol
Measuring system	Incremental encoder (RS422); max. input frequency: 1.25 MHz		Incremental encoder (RS422); max. input frequency: 1.25 MHz
Commutation	--	Hall sensor signals	Hall sensor signals
Analogue input ($\pm 10V$)	11 bit resolution		11 bit resolution
PWM switching frequency	max. 12.5 kHz	max. 16.4 kHz	max. 16.4 kHz
Inputs for limit and reference switches	✓	✓	✓
Digital current, speed and position control	Scanning times: min. 80 μs /244 μs / 488 μs for current/speed/position controllers	Scanning times: min. 61 μs /244 μs / 488 μs for current/speed/position controllers	Scanning times: min. 61 μs / 244 μs /488 μs for current/ speed/position controllers
Brake controller	✓	✓	✓
Gantry mode or synchronous control	of 2 modules, Master-Slave via CAN bus		
Monitoring of the motor current	Short circuit, I ² t	Short circuit, I ² t, Pulse-by-pulse	Short circuit, I ² t, Pulse-by-pulse
Monitoring of the encoder signals	✓	✓	✓
Monitoring of the software by internal Watchdog timer	✓	✓	✓
Simple update of the firmware over RS-232	Possible locally by customer or service engineer		
Rest state monitoring	Redundancy to ISO standard		
Dimensions	180 x 35 x 110 mm	180 x 35 x 120 mm	180 x 50 x 150 mm
Part no. Drive controllers	314 020	314 030	314 040

Motor and encoder connecting leads are NOT included in delivery.

Technical specifications subject to change.

PC controller

iPC 25



Figure:
PC controller iPC 25
with possible connection alternatives

General

The iPC25 universal PC controller is a Windows- or Linux-compatible controller at a favourable price/performance ratio. Its versatile applications may be found throughout the entire industry sector and in various consumer sectors.

All connections are made on the front. The multifunctional panel offers a wide range of connection options.

Inter alia, a CAN interface with either 1 or 2 channels is available.

A remote interface is available for covered installation (e.g. in a cabinet or in the interior of a motor vehicle).

Installation is possible both in the "standing" and "lying" positions.

Technical specifications

	iPC 25 PC controller
CPU	Intel® Dual-core Celeron® 1037U processor (1.8 GHz)
Form factor mainboard	mainboard Mini-ITX
RAM	2 x 1.5V DDR3 DIMM support up to 16 GB
Hard disks (S-ATA)	(S-ATA) 2½ Zoll ≥ 160 GB /SSD ≥ 120 GB
Graphics	Integrated Intel CPU Graphic
Monitor	VGA/HDMI
Audio	Realtek® ALC887 Codec
LAN	2 x Realtek® GbE LAN chips (10/100/1000 Mbit)
Power supply	12VDC
Operating system	Windows® Embedded Standard 7
external connections	1 x PS/2 keyboard 1 x PS/2 mouse 1 x D-Sub port 1 x HDMI port 3 x audio jacks (Line In, Line Out, Mic In) 12VDC power supply 2 x RJ-45 ports 4 x USB 2.0/1.1 ports 1 x serial port 1 x eSATA 3Gb/s connection
Internal interfaces	1 x IDE interface 1 x SATA 6Gb/s interface 2 x SATA 3Gb/s interfaces 1 x chassis intrusion header 1 x System blower header 1 x front panel header 1 x front panel audio header 2 x USB 2.0/1.1 headers 1 x parallel interface 1 x serial interface 1 x PCI slot
Humidity	Max. 90% (non-condensing)
Ambient temperature	0°C to 35°C
Protection class	IP 20
Weight	1.2 kg
Dimensions WxHxD	210 x 83 x 190 mm

Features

- Universal PC controller
- Robust, impact-proof aluminium casing
- compact configuration
- various installation options
- Energy-efficient and low-noise
- Supply voltage 12VDC
- front multifunctional panel for versatile connection options
- Design with hard disk or solid state disk (optional)
- Windows and Linux-compatible
- passive cooling
- on the front 12V connector
- Access to PC-ON/Power-LED/HDD-LED via side-mounted D-SUB9
- Access to the parallel port via side-mounted D-SUB25

Ordering Data

Part-no: **371066 0001E**

PC controller iPC 25, English
Intel-Cel2K 1.8Ghz,4GB,250GB
CAN-PCI-1 channel, serial, Remote,
12 VDC

Technical specifications subject to change.

CAN PCI board

iCC 10/20



Figure:
Single channel



Figure:
2 channels

General

CAN-PCI boards offer a simple solution for connecting a CAN bus to the PCI bus system of a PC (e.g. iPC 15).

With the CAN PCI board and based on the CANopen standard and Windows operating system, a software package for CNC control is supplied. Up to two CNC machines can even be controlled from one PC with the iCC 20.

A programming interface for creating custom user interfaces is also available.

The board can also be used in conjunction with CoDeSys V2.3.

Technical specification

	iCC 10/20
Interface	PCI V2.2/32 bit
CAN channels	40910
galvanic isolation	✓
Data transfer rate of	up to 1 Mbits/s
RJ45	connector

Features

- Mechanical dimensions: 119.5 × 47.3 mm
- PCI-V2.2-compliant
- 1 or 2-channel CAN connector: RJ45, shielded
- CAN bus galvanically isolated
- Transfer rates up to 1 Mbit / sec
- Multi-channel CNC control for PCs with NT / 2000 / XP / Vista / Win7 (32/64 bit)
- Communication via the bus with the CANopen standard

Block figure CAN bus with iPC 15

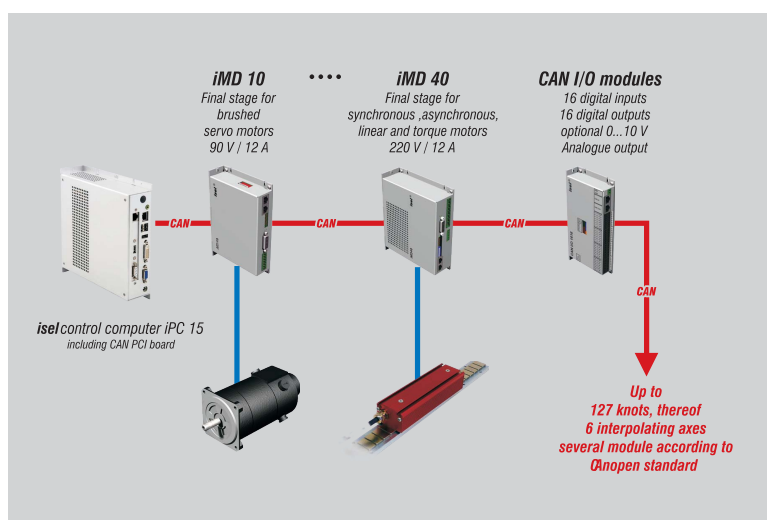

Ordering information

CAN PCI board iCC 10
Part no.: **320310** (Single channel)

CAN-PCI-Karte iCC 20
Part no.: **320311** (2 channels)

Technical specifications subject to change.

CAN controller components



CAN I/O module 16/16

CAN I/O module 8/12 - 4/1

General

Both isel CANopen I/O modules provide an entry level into the world of modern industrial automation. They enable installation on site or in a cabinet.

A 24V DC power supply, galvanic isolation of the inputs and outputs and the terminals available directly on the module provide a great range of operating possibilities.

Connection via plug-in terminals and the status display assigned directly to the connection make for particularly user-friendly installation and servicing.

Technical specification

	CAN I/O module 16/16	CAN I/O module 8/12 - 4/1
Digital inputs	16 via optical coupler (Input current approx. 8 mA)	8 via optical coupler (Input current approx. 8 mA)
Digital outputs	16 8 × relays, I _{max} < 5A 8 × electronically, I _{max} < 350 mA	12 4 × relays, I _{max} < 5A 8 × electronically, I _{max} < 350 mA
Analogue output	1 0V - 10V via 8-bit D/A converter <small>(when using the analogue output, the electronic outputs are no longer available for use)</small>	1 0V - 10V via 8-bit D/A converter
Analogue input	--	4 0V - 10V, 10-bit resolution
Protection class	IP20	
Supply voltage	24V DC (logic voltage), 24V DC (process voltage),	
Power consumption	160 mA (logic and relays) <small>I_{load} is dependent on the external wiring</small>	
Ambient temperature	-5°C to +40 °C	
Storage temperature	-25°C to +70 °C	
Relative humidity	max 95 %	
Protection class	IP20	
Weight	260 g	
Casing size	85 × 180 × 28 mm (W × H × D)	
Part no.	321002	321004

Features

CAN I/O module 16/16

- 16 digital inputs via optical coupler (input current approx. 8 mA)
- 16 digital outputs, 8 × relays, I_{max} < 5A, 8 × electronically, I_{max} < 350 mA (thermal protection, short circuit protection)
- One analogue output, 0 V - 10 V via 8-bit D/A converter (users of an analogue output can no longer use the electronic outputs)

CAN I/O module 8/12 - 4/1

- 8 digital inputs via optical coupler (Input current approx. 8 mA)
- 12 digital outputs, 4 × relays, I_{max} < 5A, 8 × electronic, I_{max} < 350 mA (thermal protection, short circuit protection)
- One analogue output, 0 V - 10 V via 8-bit D/A converter
- 4 analogue outputs, 0 V - 10 V 10-bit resolution

Technical specifications subject to change.

Step controller IT116 Flash

Single axis controller



Figure:
IT 116 Flash front



Figure:
IT 116 Flash back side

Features

- Final output stage
48 V DC / 4.2 A peak
for 2-phase stepper motors
- max. 25,600 microsteps/turn
- Mains voltage:
115V AC/230V AC, 50...60 Hz
- Automatic current sink at
50% phase current at
motor speed < 1 rpm
- Motor current/microstep resolution
variable with DIP switch
- Integrated 32-bit RISC processor
(Embedded controller) with Flash
memory for firmware and
PAL PC user program
- RS-232 interface (front) for
coupling with PC/notebook
(program download)
- Control signals:
Program start/stop, reset on
controller back side
- 4 optically isolated signal inputs
(Signal voltage: 24 V DC)
- 4 relay outputs (24 V DC, 300 mA)
- Motor brake controller (24 V DC)
- Remote plug on rear of controller
for external EMERGENCY SHUT-
DOWN (2-channel), ext. power on
- Euro cooling rib casing
- Programming with PAL-PC 2.1
for Win2000, XP, Vista, 7
- Dimensions
W 105 × H 111 × D 320 mm

General

The **IT 116 Flash step controller** is a freely programmable compact controller for a linear or circular axis with 2-phase stepper motor. The step controller comprises an intelligent step motor stage, a processor core with Flash memory for downloading/storing the PAL-PC user program and the clocking/direction signal generation for the final stage of the motor, the necessary power supply units, a safety circuit (Stop category 0 to EN 60204) and a casing with mains input filter and control elements.

The integrated operating system in the Flash memory of the processor core supports both

- DNC controller mode: PC/laptop connected permanently with the step controller via the serial interface
- and the
- CNC controller mode: the step controller works independently, without PC coupling of the stored user program (standalone).

Ordering information

IT 116 Flash step controller (115V AC, 60 Hz) Part no.: **381016 0115 ***

IT 116 Flash step controller (230V AC, 50 Hz) Part no.: **381016 ***

*** including PAL-PC**

Accessories

Motor lead
M23 12-pin socket - SubD 9-pin Pin
Part no.: **392755 0500** (5m)

Motor lead
SubD 9-pin socket - plug 1:1
Part no.: **392781 0500**

Other lengths on request.

Technical specifications subject to change.

Scope of delivery

- Controller in cassette casing
- Mating plug (I/O, pulse, remote)
- Serial interface lead (SubD9 - RJ 45)
- 230V AC mains lead
- PAL-PC software CD
- Operating instructions
- Programming instructions

Step controller

Multiple axis controller

iMC-S8



Figure:
iMC-S8 step controller as
bench version and with 19" housing

Features

- 32-bit RISC processor with Flash memory for user program
- Final output stages
 - Step resolution and motor current adjustable via variable DIP switch
 - automatic current sink
- Acceleration, start-stop frequency and step output frequency variable
- both hardware limit switches configurable
- Door controller/hood controller
- Control elements in the front of the casing
- external EMERGENCY SHUTDOWN and POWER connection for integration in higher level safety circuits
- Connection for external control signals, such as START, STOP, RESET (only CNC mode)
- 230V connection for milling spindle (100-230V AC)
- 0 .. 10V analogue output for external frequency converter for speed-controlled main spindle
- Programming/Operation
 - PAL-PC in CNC mode (in the scope of delivery)
 - Remote (optional: ProNC) in DNC mode
 - isel @ - format in CNC/DNC modes

General

The **iMC-S8** step controller is a freely programmable compact controller for linear or circular axes with 2-phase step motors.

The controller integrates all the necessary components (power supply, safety circuit, power electronics, core processor, interfaces, operating elements) that are needed to control individual spindles all the way to entire machines. It has an intelligent core module that is controlled and programmed via a RS232 interface. The core module also converts the commands programmed in the user program into clocking/direction signals for the connected final stages. Depending on the purpose, the **iMC-S8** controller can be used either in CNC or in DNC mode.

In CNC mode, the processor processes the CNC program which was previously produced with PAL-PC and stored in the controller's Flash memory.

In DNC mode, the **iMC-S8** controller is connected permanently with a control computer (PC, laptop) via a serial interface (RS232). Processing is carried out via the isel control software Remote.

Technical specification

- Broadband mains supply
100 - 250V AC, 50..60Hz
- Processor
 - Flash memory 128 kB, Capacity to store 350 commands
 - max. step output frequency 40 kHz
- Final stages
 - Power supply 48 VDC
 - Peak current: 1,0 - 4,2 A (MD 24)
2,8 - 7,8 A (MD 28)
 - Step resolution: 400-51200 steps
- Inputs/outputs
 - 16 inputs (24V DC)
 - 16 outputs (24V DC/300mA, Itot 2A)
 - 1 relay output (230V AC, max. 6A)
 - 1 analogue output (0 - 10V)
- RS232 operating/programming interface
- Stop category 1, safety category 2
- Versions:
 - Bench casing
W 475 × H 410 × D 187.5 mm
 - 19" housing
W 482.5 × H 410 × D 175.5 mm

Ordering information

3 8 3 3 2 0 X X 1 X

Variant

- 1 = 19"-housing
- 2 = bench housing

Drive module

- 0 = MD 28
- 1 = MD 24

Numbers of axis

- 2 = 2 axis
- 3 = 3 axis
- 4 = 4 axis

Scope of delivery

Controller, mating plug (I/O, pulse, Remote), serial interface lead (null modem), 230V AC mains lead, PAL-PC software CD, operating instructions, programming instructions

Accessories

Motor lead M23 plug - M23 socket

Part no.: **392750 0300** (3m)

Part no.: **392750 0500** (5m)

Motor lead M23 plug - SubD9 socket

Part no.: **392752 0300** (3m)

Part no.: **392752 0500** (5m)

Controller software - Remote

Part no.: **Z12-334500**

Controller and programming software ProNC

Part no.: **Z11-333500**

Technical specifications subject to change.

Single axis controller MC1-10/20/40

iMD single axis controller for isel linear units

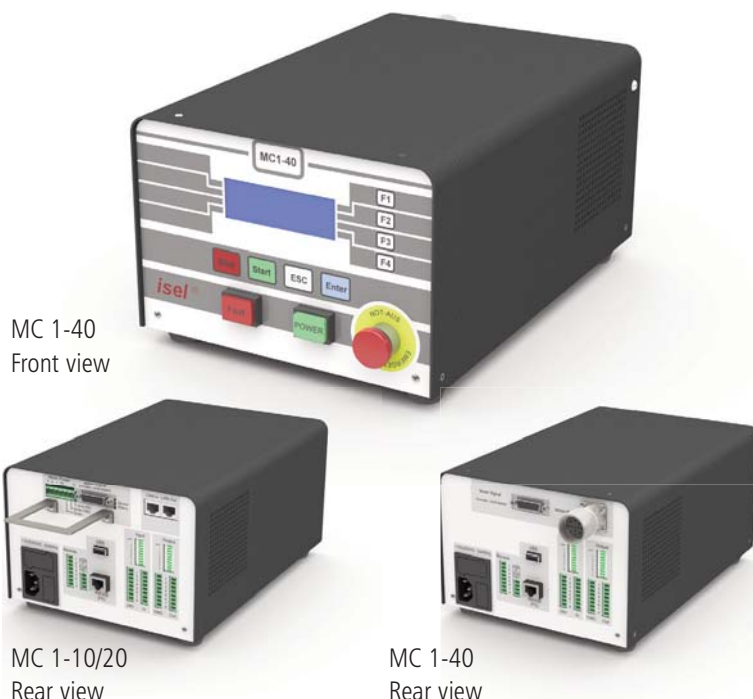

MC 1-40
Front view

MC 1-10/20
Rear view

MC 1-40
Rear view

General

MC 1 series servo-controllers are freely-programmable compact controllers for linear or rotating units with servomotors. The single axis controllers integrate all the components (interfaces, motion controller, power supply, drive controller, safety circuit, control elements) needed for axis control in compact bench housings. The supplied PAL-PC software can be used for programming.

There are three MC1 variants available:

- MC1-10: for controlling brush-type DC servomotors (48 V)
- MC1-20: for controlling brushless EC servomotors (48 V)
- MC1-40: for controlling brushless EC servomotors (310 V)

Ordering information

MC 1-10 (including PAL-PC)	Part no.: 381518 0010
MC 1-20 (including PAL-PC)	Part no.: 381518 0020
MC 1-40 (including PAL-PC)	Part no.: 381518 0040

Motor leads MC 1-10/20	Part no.: 392760 xxxx*
Motor leads MC 1-40	Part no.: 392307 xxxx*

Encoder lead	Part no.: 392740 xxxx*
--------------	-------------------------------

* Leads available in different lengths,
e.g.: 0100 = 1 m / 0150 = 1.5 m / 0200 = 2 m ... / 1000 = 10 m

Technical specifications subject to change.

Features

MC1-10

- For controlling brush-type servomotors with an intermediate circuit voltage of 48 V DC
- Setup program "DcSetup"

MC1-20

- For controlling brushless servomotors with an intermediate circuit voltage of 48 V DC
- Analysis of Hall signals
- Setup program "AcSetup"

MC1-40

- For controlling brushless servomotors with an intermediate circuit voltage of 310V DC
- Analysis of Hall signals
- Setup program "AcSetup"

Common features

- Max. output power 500 W (MC1-10, MC1-20)
- 32-bit high performance RISC processor with 256 kB Flash memory
- User program in CNC mode for up to 650 commands
- Processing of the program in CNC or DNC mode
- Programming with PAL-PC (CNC and CNC mode), @-format (CNC mode), ProNC, Remote (DNC mode)
- LC display with 4 lines, each with 20 characters (freely programmable)
- Additional control signals (Start, Stop) adaptable
- Connection for incremental encoder
- 6(8) signal inputs (24 V DC)
- 8 relay outputs (24 V DC/700 mA)
- Stop category 0 in accordance with EN60204
- Emergency shutdown circuit via plug in higher level safety circuit integrable
- Broadband mains supply:
 - 110...250 V AC, 50..60 Hz (MC1-10 / MC1-20)
 - 250 V AC, 50Hz (MC1-40)
- Bench casing
W 204 × H 149 × D286

Scope of delivery

- Controller
- Mating plug (I/O, pulse, remote)
- Serial interface lead (SubD9 - RJ 45)
- 230V AC mains lead
- PAL-PC software CD
- Operating instructions
- Programming instructions

Multiple axis controller

iMD multiple axis controller for isel linear units

iCU-DC / iCU-EC



iCU-DC
Front view

iCU-DC
Rear view

General

The **CAN controllers** of the **iCU-DC** and **iCU-EC** series are compact, high-performance drive controllers for 2 - 6 DC servomotors and are offered at an optimal price / performance ratio.

The bench housing integrates all control components needed to solve a wide variety of automation tasks, ranging from the final stage via the I/O assembly to the safety controller.

The control computer has an integrated CANopen PCI card interface serving as CAN Master for the drive controller and I/O components. External upgrades are also possible, up to 128 CAN nodes. The connecting points at the rear of the control computer facilitate easy connection to (for example) a monitor. Peripherals such as a mouse and keyboard can be connected at the USB interfaces provided. LAN connection allows integration into an existing network and can be used for remote servicing.

The NC control core facilitates the interpolation of up to 6 axes (linear, circular, helical) as well as Online and Look Ahead machining. When using the ProNC software, individual axes can be controlled as handling axes (in addition to the interpolating axes).

All final stages have automatic jerk limitation and rest state monitoring (up to safety category 3).

Ordering information

3 5 4 0 0 2 X 0 X 0

Number of axes

- 2 = 2 axes
- 3 = 3 axes
- 4 = 4 axes
- 5 = 5 axes
- 6 = 6 axes

Versions

- 1 = iCU DC* (brush-type DC servomotors)
- 2 = iCU EC* (brushless EC servomotors)

Accessories

- Motor lead M23 pin - M23 socket
Part no.: **392759 0300** (3m)
- Part no.: **392759 0500** (5m)

- Encoder lead SubD 15 plug - SubD15 socket
Part no.: **392740 0300** (3m)
- Part no.: **392740 0500** (5m)

Features

- Drive controller for up to 6 brush or brushless DC servo motors
- NC control via CANopen field bus
- iMD10/iMD20 final output stages
 - 4-quadrant drive controller
 - Analysis for incremental encoder
 - Rest state monitoring
 - Over- and undervoltage protection,
 - Overtemperature protection, short-circuit proof
- Door control / hood control
- External emergency cut-out for integration into higher level safety circuits
- Connection for external control signals (START, STOP, RESET) via signal inputs
- Control computer connections:
 - VGA, 4 x USB (2 x front, 2 x rear),
 - RJ45 Ethernet (100 Mbit/s)
- Connection for milling spindle (100 -230V AC)
- 0 ...10 V output for external frequency converter for speed-controlled main spindle
- Front-sided control elements
- Industrial control computer based on Windows® with
 - CANopen PCI board
 - driver software for CNC control
- Programming/Operation
 - Remote (optional: ProNC)

Technical specification

- Broadband mains supply
 - 115 V AC / 230 V AC, 50...60 Hz
- Switching power supply 1000 W / 48 V
- iMD10/iMD20 final output stages
 - Power supply: 24...80 V DC
 - Peak / nominal current: 25 A / 12 A
- Input/output of CAN E/A module
 - 4 digital inputs, 8 digital outputs
 - 1 relay output (230V AC, max. 6 A)
 - 1 analog output (not required with frequency converter option)
- CAN safety circuit module
 - up to safety category 3
 - door circuit control
 - spindle control
- Bench casing
 - W 630 x H 230 x T 400 mm
- Options:
 - frequency converter for iSA500 - iSA2200
 - additional CAN I/O module (16 x inputs, 16 x outputs)

Scope of delivery

- Controller
- Mating plug (I/O, pulse, remote)
- 230V AC mains lead
- Operating and programming instructions

Technical specifications subject to change.

Power unit

Multiple axis controller

iPU-DC/iPU-EC



Figure:
Power unit iPU as
bench version and with 19" housing

Features

- Drive controller for up to four brush or brushless DC servo motors
- NC control via CANopen field bus
- iMD10/iMD20 final output stages
 - 4-quadrant drive controller
 - Analysis for incremental encoder
 - Rest state monitoring
 - Over- and undervoltage protection, Overtemperature protection, short-circuit proof
- Door controller / hood controller
- Connection for external control signals, (EMERGENCY SHUTDOWN, START, STOP) for integration in higher level safety circuits
- Connection for milling spindle (100 -230V AC)
- 0 .. 10V output for external frequency converter for speed-controlled main spindle
- Front-sided control elements (optionally, installed in the rear)
- Two alternative casings
- Programming/Operation
 - Remote (optional: ProNC)

Technical specification

- Broadband mains supply
 - 115 V AC / 230 V AC, 50..60 Hz
- Switching power supply 1000 W / 48 V
- Final output stages iMD10 / iMD20
 - Power supply: 24 - 80 V DC
 - Peak / nominal current: 25 A / 12 A
- Inputs/outputs
 - 4 digital inputs (24 V DC / 8 mA)
 - 8 digital outputs (24 V DC / 350 mA)
 - 1 relay output (230 V AC, max. 6 A)
 - 1 analog output (0 - 10 V)
- Safety controller
 - up to safety category 3
 - door circuit and spindle control
- RJ 45 CANopen interface
- Versions:
 - Bench housing
W 475 x H 410 x D 187.5 mm
 - 19" housing
W 482.5 x H 410 x T 175.5 mm

Scope of delivery

- Controller
- Mating plug (I/O, pulse, remote)
- CAN bus lead (RJ45, patch lead)
- 230 V AC mains lead
- Operating instructions

General

The **iPU power units** are powerful drive controllers for up to four linear or circular axes with brush or brushless motors. The compact controller integrates all necessary controller components, which are needed to solve a wide range of automation tasks. These range from iMD10 or iMD20 final output stages through the I/O module to safety control and power electronics.

As its interface for NC control, the **iPU power unit** has a CANopen interface at the back of the housing, which works according to the DS301 bus protocol and DS402. By using the optional CAN PCI board iCC 10 or a iPC series control computer, the controller can control interpolation (linear, circular, helical) of all four axes as well as track processing.

The final output stages (iMD10 or iMD20) also have automatic jerk limitations and rest state monitoring. The control elements integrated in the front of the housing, such as EMERGENCY SHUTDOWN, START or STOP enable convenient operation.

Ordering information

3 5 3 0 0 0 X 0 X X

Number of axes

- 2 = 2 axes
- 3 = 3 axes
- 4 = 4 axes

Versions

- 1 = 19" housing
- 2 = Bench housing

Drive controller

- 1 = iMD 10 (brush DC servomotors)
- 2 = iMD 20 (brushless EC servomotors)

Accessories

Motor lead M23 plug - M23 socket

Encoder lead SubD15 plug - SubD15 socket

CAN PCI board iCC 10 (single channel)
CAN PCI board iCC 20 (2 channels)
Controller software - Remote
ProNC control software

Part no.: **392759 0300** (3m)
Part no.: **392759 0500** (5m)
Part no.: **392740 0300** (3m)
Part no.: **392740 0500** (5m)
Part no.: **320310**
Part no.: **320311**
Part no.: **212-334500**
Part no.: **211-333500**

Technical specifications subject to change.

CAN-CNC controller

Example of a topology with the isel-CAN-CNC controller

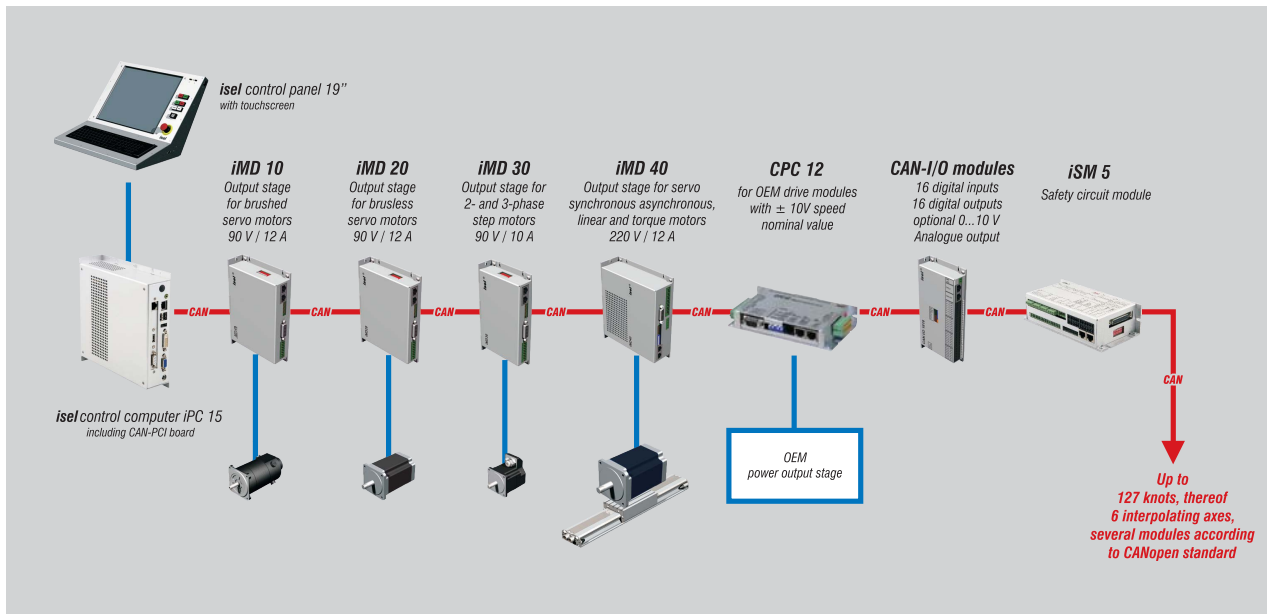

With consequent use of the CiA's (CAN in automation) **CANopen** standards, isel Germany delivers a high quality PC-based **CAN-CNC controller** for intelligent positioning/drive units and I/O modules.

The **CAN-CNC controller** supports interpolation operation (linear, circular and helical) of up to six positioning drives per machine and up to 127 handling axes and CAN modules.

The high time demands of a CNC controller are guaranteed by a WDM driver developed by isel. An additional real time operating system for Windows will be unnecessary. This guarantees compatibility with future Windows versions

The CAN controller is a pure software solution for PCs with Windows 2000/XP/VISTA/Win7 (32/64 bit). The CANopen PCI boards iCC 10/20 also act as an interface.

Owing to the features provided, the **CAN-CNC controller** is equally suited for all machining tasks, such as milling, engraving, drilling, turning, water jet and laser cutting, as well as for applications in automation systems.

For this purpose, **ProNC** provides a universal programming environment.

Features

- Machine control to the **CANopen** standard as a pure software solution for PCs with Windows 2000/XP/VISTA/Win7 (32/64 bit)
- CiA-Standard, DS 301, DSP 401, DSP 402
- Supports up to six positioning axes and 127 handling axes and CAN modules.
- Look ahead track processing with a freely definable number of movement elements, which the controller processes while looking ahead.
- Jerk limitation for elimination of mechanical vibrations
- Upstream speed control for highly dynamic and lag error-free machining
- Software tools for setting and optimising motor final stages/positioning modules
- Interfaces for PC:
 - CANopen PCI board iCC 10 (single channel)
 - CAN bus 1
 - CANopen PCI board iCC 20 (two channels)
 - CAN buses 1 and 2

Technical specifications subject to change.

Space for your notes

Software





SOFTWARE

Software and
control organization D-2

CAD / CAM software

isy-CAM 2.8 D-4

OneCNC D-5

Mastercam D-5

Interpreter software

Remote D-6

Programming software

PAL-PC 2.1 D-7

ProNC D-8

isy-CAM 2.8 and 3.6

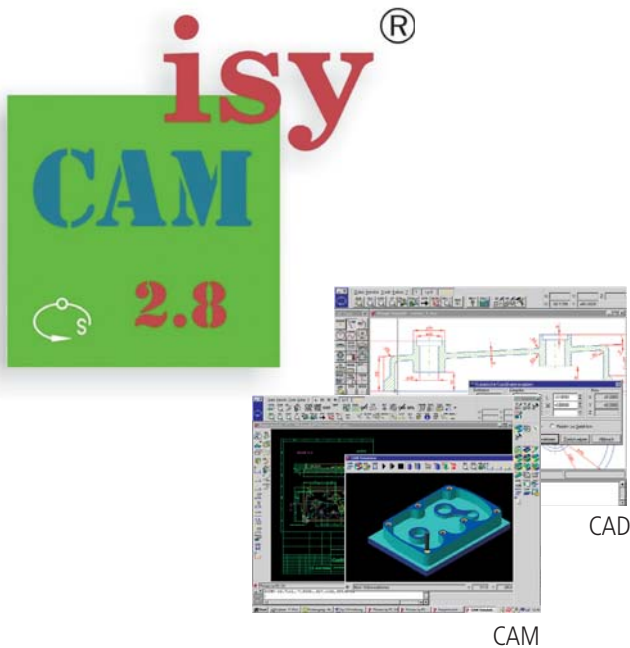

Features isy-CAM 2.8

- CAD functionality (without volume modeller)
- works with Win XP, Windows 7 and 8, 32-/64-bit version
- Import: DXF / EPS / AI / 3D STL data
Export: NCP format
- proven CAM strategies
- for drilling / contour and pocket milling
- engraving with thinning
- engraving on cylinder surface with 4th axis
- 3D roughing and finishing of STL data (e.g. 3D scanning models)
- direct call of REMOTE out of isy-CAM

Features isy-CAM 3.6

- advanced mesh manipulation
- 32-/64-bit version
- Hybrid milling (steep and flat areas in one step)
- trochoidal milling
- revised residual material detection and handling
- Multi-sided machining (3+2 axis, hired milling)
- extendable to 5 simultaneous-moveable axes

Ordering data

isy CAM 2.8

Part-no.	Description
Z13-337070	isyCAM2.8, 2.5D CAD/CAM Software, including 3D STL manipulation, PC bound, without training
Z13-337070 0001	isyCAM2.8, 2.5D CAD/CAM Software, requirement: registered 2.5/3.0 version, including 3D STL manipulation, PC bound, without training
Z13-337070 0002	isyCAM2.8, 2.5D CAD/CAM Software, including 3D STL manipulation, PC bound, with training at isel
Z13-337070 0003	isyCAM2.8, 2.5D CAD/CAM second license, PC bound, without training

isy CAM 3.6

Part-no.	Description
Z13-337071	isyCAM3.6, 3+2 axis, including NCP - PPRO, PC bound, including training for 1 person at isel
Z13-337071 0001	Update isyCAM 2.0 / 2.5 / 2.5plus to isyCAM 3.6, 3+2 axis, including NCP - PPRO, PC bound, without training
Z13-337071 0002	Update isyCAM 3.0 / 3.2 to isyCAM 3.6, 3+2 axis, including NCP - PPRO, PC bound, without training
Z13-337071 0003	Update isyCAM 3.0 / 3.2 to isyCAM 3.6, 3+2 axis, including NCP - PPRO, PC bound, without training
Z13-337071 0004	Update isyCAM 2.8 to isyCAM 3.6, 3+2 axis, including NCP - PPRO, PC bound, without training
Z13-337071 0005	Update isyCAM 3.6 second license, PC bound, without training
Z13-337071 0006	Exchange-Package 3.6 (IGES, VDA, STEP)
Z13-337071 0007	Update Exchange-Package 2.0 to 3.6 (IGES, VDA, STEP)
Z13-337071 0008	Update Exchange-Package 3.0 to 3.6 (IGES, VDA, STEP)
Z13-337071 0009	Update Exchange-Package 3.2 and 3.4 to 3.6 (IGES, VDA, STEP)

Common features

- Multi-core support
- dynamic rotatable simulation
- freely definable line styles and colors
- integrated online help, configurable user interface
- parallel and independent work on several drawings
- geometric elements such as points, lines, ellipses, circles, curves (polygons, splines, bezier curves, NURBS), polygons etc.
- direct use of the Windows fonts
- professional functions for editing figures and texts
- hatching, user-defined hatch patterns
- automatic functions for positioning and aligning
- contours sketching and change interactively
- numeric input methods for absolute, relative and polar coordinates
- extensive DIN / ISO-compliant measuring- and dimensioning functions
- trimming, cutting and drawing curves and conversions of different geometrical types
- geometrical manipulation by moving and copying as translation, rotation, scaling, mirroring
- intelligent object snap
- optimal control of the calculated NCP data through integrated online simulation of tool paths
- production of processing data for all typical 2D and 2.5D machining tasks
- Output format: NCP format

OneCNC milling



Advantages

- High speed toolpaths for 2D and 3D machining that creates a toolpath that delivers more consistent cutting
- Automatically machine flat areas using smooth entry, exit and cut motion.
- Feature based milling for hole making with automated feature detection
- High speed scallop cutting delivers a consistent finish.
- Planar and Z level finishing delivers a smooth cut with consistent material contact.
- High speed Z level cutting delivers constant Z moves with smooth entries and exits.
- Smooth, automated clean circle milling
- High speed pencil tracing removes material from the outside in with smooth motion.
- High speed pocket milling from the inside out safely around islands with the automatic rest ability
- High speed rest roughing smoothly removes material left from a previous rough pass.

Mastercam



Mastercam®

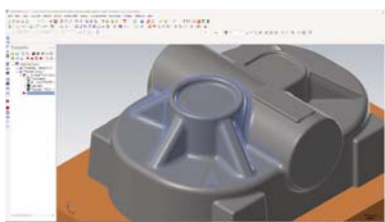

General

Mastercam is the most commonly used CAM software and the first choice among CNC programmers. It gives your manufacturing operation, the best possible foundation for fast and efficient milling. From general procedure as the optimized pocket machining to highly specialized toolpaths such as the 5-axis milling turbine, with Mastercam you are guaranteed ready for any assignment.

Whether simple or complex 2D machining - with the tools of Mastercam you optimize the time required.

Advantages

Contouring

- separate entrances and exits for contour and pocket finishing
- several roughing and finishing passes and several deep cuts for a contour
- easy processing of 2D and 3D contours with parametric and NURBS splines

Drilling

- automatic detection and pre-drilling of multiple operations at their plunge points
- automatic calculation of the countersink depth
- Optimization of drilling routines to minimize the traverse of the tool

... and much more!

Pocketing

- dynamic milling (toolpath with constant cutting conditions)
- area link for quick and easy adjustment of the areas for 2D high speed machining
- Pocketing with various rough-out strategies (HSC, zig-zag, one-way, true spiral, constant overlap and blend spiral - each with optional finishing pass)

... and much more!

Rest machining

Powerful roughing

Versatile finishing

Feature based machining (FBM)

... and much more!

Remote

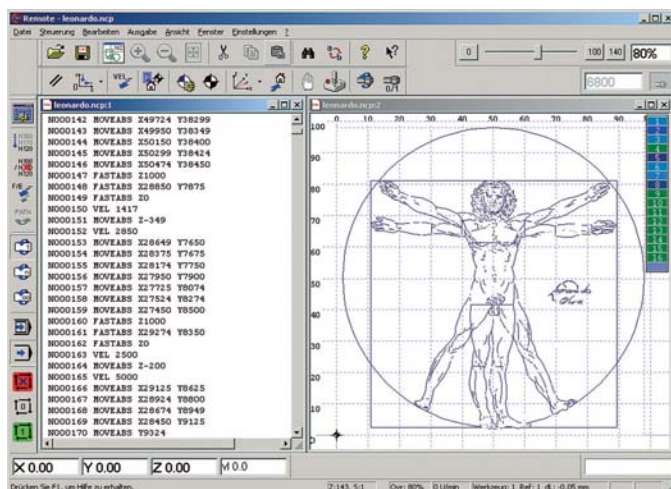

Control software for Windows

General

Remote is a universal control program for outputting files for machining methods milling, drilling, adhesive bonding, engraving, applying and water jet cutting or laser cutting/welding.

Supported file formats are the isel-specific NCP format (ASCII file with machining data generated by a CAM post-processor, the isel-specific CNC format (ASCII files in an expanded format for universal use in the process automation area, generated by ProNC) and the G-code format to DIN 66025.

Remote is used first and foremost for controlling CNC machines operating different tasks and processes, which is why flexibility is a key feature of the program. A large choice of options allows easy adaptation to current requirements in each case.

Features

- Support for digital joysticks
- "Fast file selection" control panel for serial production
- Milling/multiple output with movements
- Graphic depiction of the processing file with zero point and dimensions

isel-NCP, DIN66025/G-code file formats

- Linear and circular interpolation, helical interpolation, drilling cycles
- Access to digital and analogue inputs and outputs
- When using a CAN controller: "On-the-fly" input/output (without stopping the movement) for metering applications
- Message window, messages in the status line, time delay, input of variable values
- Definition and use of machine positions (tool zero point, park position, home position, etc.)

Additional features for the isel-CNC file format (ProNC output format)

- Repeating loops, counting loops, unconditional and conditional branches
- Arithmetic and trigonometric functions
- Sub-program systems
- Real and symbol chain variables
- Loading and storing process variables
- Access to user-specific expansions, option to call up user software

Ordering information

Part no.: **Z12-334500**

Remote - software for CAN-CNC controllers (Windows)

Features

- runs with Windows operating systems (Windows 2000, XP, Vista)
- compatible with previous software versions
- Processing of DIN66025 (G-code) file formats, NCP or CNC
- immediate processing without conversion, File translation or conversion
- integrated text editor with numerous features for rapid corrections to the present NC program
- Use of up to 6 interpolating axes (Cartesian coordinates system and 3 auxiliary axes)
- Look-ahead track processing with CAN controller
- Managing a milling spindle
- 2 I/O units can be used (max. 64 inputs, 64 outputs)
- Signalling inputs and outputs for process synchronisation
- manual axis movement with joystick, keyboard and mouse
- incremental processing and system monitoring for commissioning
- Configurable interface for user-friendly operation, serial production, handshake with master PLC, etc.
- Control panel for movement control, input/output, spindle and tool change with buttons
- Control panel for max. 6 handling axes independently of the interpolating axes
- available in various languages (German, English, French, Magyar)

PAL-PC

Process automation software for Windows

free updates

under
www.isel-germany.de



General

PAL-PC enables rapid, easy and low-cost implementation of automation projects such as handling systems, drilling machines, clamping devices, test and measurement systems, machines for individual and serial processing and much more....

PAL-PC is a modern program development environment for CNC step motor controllers and CNC machines

PAL-PC uses **memory operation** (CNC mode) for the target controller. PAL-PC produces automation solutions in which the controller works in standalone mode, i.e. independent of a control computer.

PAL-PC runs with Windows 2000, XP and Vista operating systems.

Features

- Path commands for relative and absolute positioning
- Carry out movement until event occurs at an input
- Teach-in-programming (linear)
- Linear 2D interpolation, switchable to 3D interpolation
- Circular interpolation
- Input signal analysis for process control
- Loops for repeating of instruction blocks
- Unconditional and conditional branches
- Analysis of the program selection unit
- Output of messages to a display
- Sending and receiving synchronisation marks
- Additional aids for automated processing of typical tasks

Ordering information

Part no.: **Z11-331810**

PAL-PC - software for CAN-CNC controllers (Windows)

Features

- compatible with previous versions (PAL-PC programs, which were produced with an earlier release of PAL-PC, can be used without adaptation)
- Programming to isel-PAL or DIN66025: In addition to the PAL format, users who know programming to DIN66025, can also produce their PAL-PC applications with corresponding G-code commands.
- Integrated editor: fast and convenient editing of source texts, editor features such as "Search", "Replace", "Copy" and "Insert" automated code generation, multiple Undo/Redo for efficient programming
- PAL-PC can (depending of the type of controller used) control controllers with up to 4 axes
- Terminal for direct communication with the controller
- Downloading of externally generated CNC programs
- Automatic calculation of type and data transfer rate of the connected controller
- Display of compiler errors and navigating to an error in the source code
- Command rapid overview with optional insertion into the program
- Teach-in-programming with keyboard or mouse
- Acceptance in the editor of target positions as formatted source code
- Live status display at the inputs
- Setting outputs during program generation
- available in German and English

ProNC

Process automation software for Windows

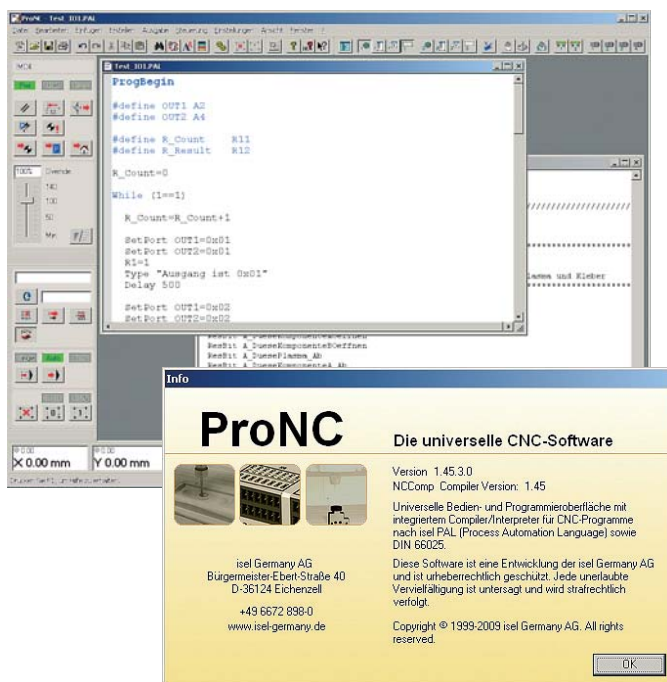

General

The basis of any automation solution is a powerful software that enables implementation of practical solutions for existing tasks quickly and conveniently. In these cases, the operating and programming interface ProNC provides an ideal solution.

ProNC runs with the Windows 2000, XP and Vista operating systems.

ProNC is available for a variety of control systems and controllers from isel

ProNC applications can be produced to isel-PAL or DIN66025

ProNC is outstandingly suited to automation solutions in the milling, drilling, metering, installation, handling, loading and quality control fields, in which application programs are produced mainly in text format, using teach-in-features and the integration of contour data sets (e. g. NCP format).

Features

- Path commands for relative and absolute positioning of the interpolating axes
- Programming of additional axes in handling mode
- Circular interpolation, helical interpolation, drilling cycles
- Repeating loops, counting loops, unconditional and conditional branches
- various mathematical and trigonometric functions
- Sub-program systems, symbolic variables
- Real and symbol chain variables
- Message window, messages in the status line
- Loading and storing process variables
- Access to digital and analogue inputs and outputs
- "On-the-fly" input/output (without stopping the movement) for metering applications
- Access to user-specific extension DLLs
- convenient support for debugging (interruption points, monitoring of status and variable)

Ordering information

Part no.: **Z11-333500**

ProNC - software for CAN-CNC controllers (Windows)

Features

- Programming to DIN66025 (G-codes) or isel-PAL
- compatible with previous software versions (ProDIN, ProPAL)
- integrated text editor with numerous features for rapid and efficient source code processing
- Import of geometric data (NCP, e.g. from isy-CAD/CAM)
- Use of up to 6 interpolating and up to 6 handling axes (with CAN controller)
- Look-ahead track processing with CAN controller
- up to 4 spindle motors can be used
- up to 4 I/O units can be used (max. 64 inputs, 64 outputs)
- Signalling inputs and outputs for process synchronisation
- Teach-in-with joystick, keyboard and mouse
- Offline programming with simulation modules
- incremental processing, hold points and system monitoring for commissioning
- individually expandable with software libraries
- Control panels for movement control, input/output, spindle and tool change with buttons
- Control panel for max. 6 handling axes independent of the interpolating axes
- available in German and English

Training courses and application solutions to order.

Space for your notes

system

made by *isel*

FLAT CO

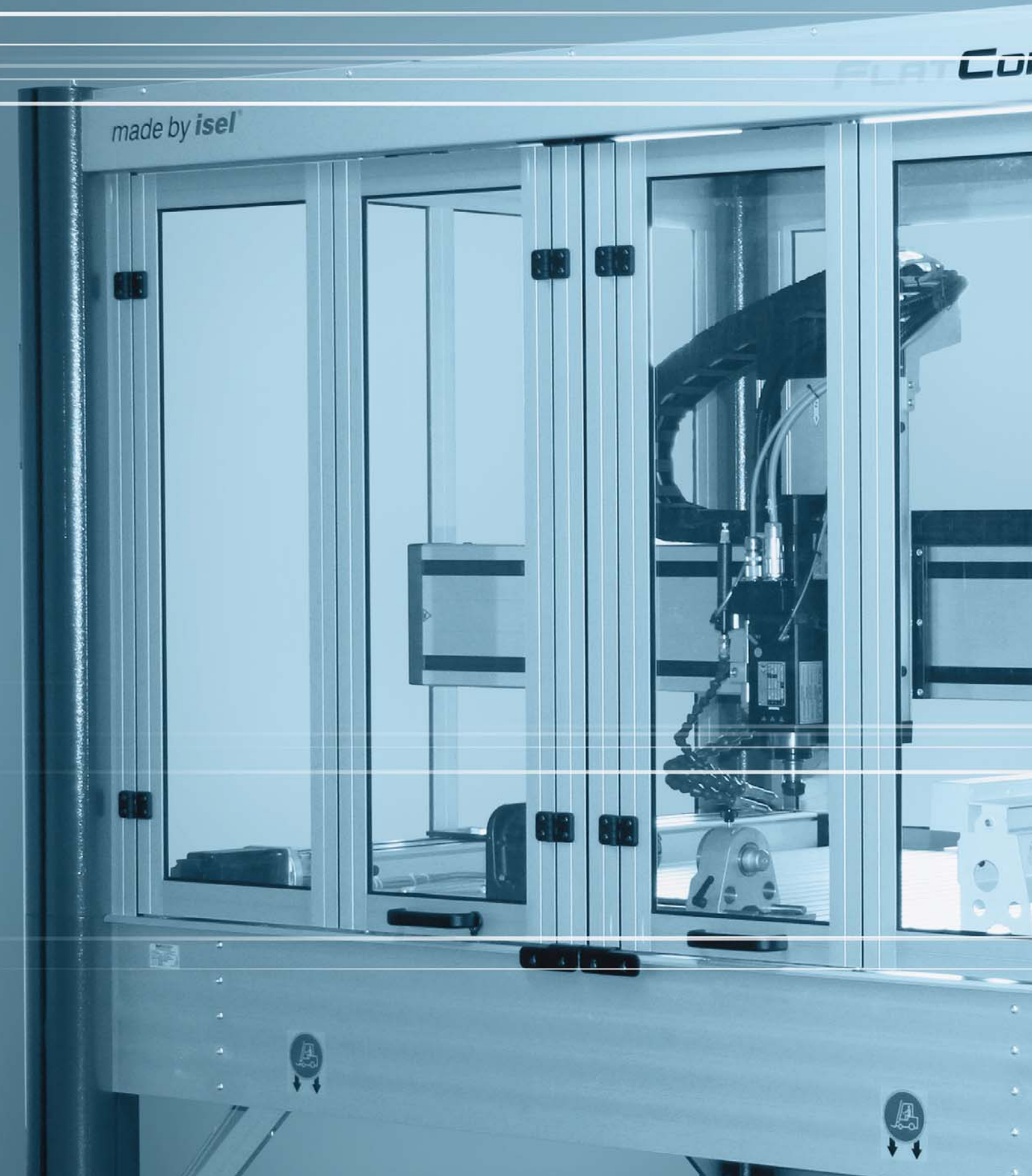

ms



SYSTEMS

CNC machines E-4
with step motor or servo motor drive

Accessories E-22

Robotics E-44

CNC machines

Overview

General, Maintenance contracts

E-4

CNC desktop machines
series ICP / ICV

E-6



CNC machine
OverHead Gantry

E-10



CNC machine
EuroMod

E-12



CNC machine
FlatCom series M

E-14



CNC machine
FlatCom series L

E-16



CNC machine
FlatCom series XL

E-18



Flat bed and portal units

E-20



CNC machines

Overview

Accessories

E-22

Spindle motors

E-23

iSA 500 with manual tool changer
 iSA 750 with manual tool changer
 iSA 1500 with manual tool changer
 iSA 1500 L with manual tool changer

iSA 900 with automatic tool changer
 iSA 2200 with automatic tool changer
 iSA 1500WL with automatic tool changer
 iSA 3600 with automatic tool changer
 iSA 1500 W with automatic tool changer

UFM 500 / UFM 1050, Engraving spindle
 high frequency spindles HFS 800 / 2200

Extraction devices

E-34

CoolMin tool cooling system

E-36

Tool changing stations

E-38

Frequency converter

E-41

Length measuring sensor
 Motor leads
 Vacuum cleaning

Collets, Tool holders

E-42

Vacuum clamping plates

E-43

ROBOTICS

E-44

Wafer Handling Robots IWH Serie 1
 Wafer Handling Robots IWH Serie 3
 Controller & Software
 „Standard“ and „Advanced“
 Linear Track iLD series
 End effectors
 Prealigner LPA series
 Accessories

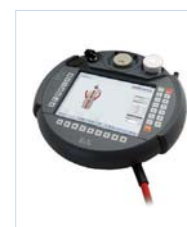

General



The CNC machines from isel Germany AG furnishes plant manufacturers and users a fit occasion. Efficient mass production in the machinery and plant sector is desirable for each manufacturer, however not invariably realizable in reference to the increasingly specialized areas of application of the customers. We, the isel Germany AG, have set ourselves the claim to successfully realize your requirements with our machines - be it in the form of a plug-and-play version or as an open system in various sizes, in which you can integrate your application easily later. Modular structure with light frame construction, isel linear axes, precision steel shafts and patented linear bearings have proved themselves over the years and are subject to continuous optimization. Our clearance-free ball screw drives with hardened and polished ball screw spindles in different diameters and pitches, step and servo motor operation or direct drive with linear and torque motors allows you to tailor your system technically to your needs - a scope which sometimes hosts price advantages. In addition to established programming and interpreter software, you can refer the 3D CAD / CAM software isy 2.8 and 3.6, for which we also offer individual training at our plant or at your place. Our slogan "From Components to Systems" underlines how important it is for us, to know our machines to the smallest detail and give you the opportunity to purchase all from one source. A wide range of accessories such as speed-controlled spindle motors, tool changing stations in various designs, patented tool cooling and handling systems from our area isel Robotics complete our range of products. In the new development and manufacture of our systems, security plays an important role. All systems are subject to the Machinery Directive 2006/42EG.

Do you have questions about your application? Contact us!

Our trained staff from the technical sales can advise you and submit a detailed quotation on request. Planning, realization and completion of your project in the form of design and manufacture of special machines belongs to the same extent to our offered services such as a customer-oriented after-sales service. Feel free to contact us!

phone: +49 (0) 6659 / 981 790 or sales@isel.com

Leasing / Financing



Our financing partners at MMV Leasing know how important a quick and professional completion of financing agreements is for our customers. We work closely with you to get the right financial package to suit your individual business objectives. Whether you opt for a new model or a used machine from isel: together we will draw up the finance quote that suits you.

Your benefits

- Longstanding experience with top financiers
- Short response time with secure and quick credit assessment

Maintenance packages

Hotline

You can reach us from **Monday-Friday between 7:30 a.m. and 04:30 p.m.,
Saturday / Sunday every day from 9:00 a.m. til 3:00 p.m.**
as well as for the free maintenance via Internet (TeamViewer)
**Monday-Friday between 7:30 a.m. and 04:30 p.m.
Saturday / Sunday every day from 9:00 a.m. til 3:00 p.m.**



Similarly, a remote maintenance by our trained employees and over the Internet (TeamViewer) is possible!



Special design of the FlatCom XL
for milling of foams for the orthopedic industry

Nobody can afford a production stoppage and we ensure the reliability of your isel product at all times. Regular maintenance by our highly qualified service technicians guarantees the greatest precision and reliability – for the lifetime of the machine. We maintain your machine in a professional, safe and reliable manner. Ask your isel contact if you are interested in a maintenance package.

The maintenance packages are available in the following versions:

	STANDARD	COMFORT	EXCELENT	
services included	1x annual maintenance, inspection and execution of small repairs	2x annual maintenance, inspection and execution of small repairs		
	1 x driving	2 x driving		
	1 x working time during the annual maintenance	2 x working time during the annual maintenance		
	1 x cleaning of the mechanical components including lubrication of the axes	2 x cleaning of the mechanical components including lubrication of the axes		
	1 x update of the firmware in the controllers and of the software	2 x update of the firmware in the controllers and of the software		
	1 x visual inspection and, where appropriate, renewal of the safety warnings and other labels in accordance with the Machinery Directive	2 x visual inspection and, where appropriate, renewal of the safety warnings and other labels in accordance with the Machinery Directive		
	1 x testing, adjustment of the belt tension and measuring of the system	2 x testing, adjustment of the belt tension and measuring of the system		
	--	10% discount of spare parts and other work	15% discount of spare parts and other work	
	€ 450,- drive flat-rate (individual)	€ 450,- drive flat-rate per maintenance (individual)		
	Service within 72 hours from Monday - Friday, except bridging days and public holidays (in Hesse and Thuringia)	Service within 48 hours from Monday - Friday, except bridging days and public holidays (in Hesse and Thuringia)	Service within 24 hours from Monday - Friday, except bridging days and public holidays (in Hesse and Thuringia)	
Item-No.:	991000 0039	991000 0040	991000 0041	

CNC machine

with step motor drive

ICP 4030



ICP 4030 with hood open

Features

- tried-and-tested technology
- for over 20 years
- over 2,000 systems sold
- Operation possible without a connection to a PC
- suitable for school and training



ICP 4030 with hood closed

Dimensioned drawings

	ICP 4030
Width W [mm]	780
Depth D [mm]	850
Height H1 [mm]	810
Height H2 [mm]	770
Height H3 [mm]	1,203
Height H4 [mm]	1,250

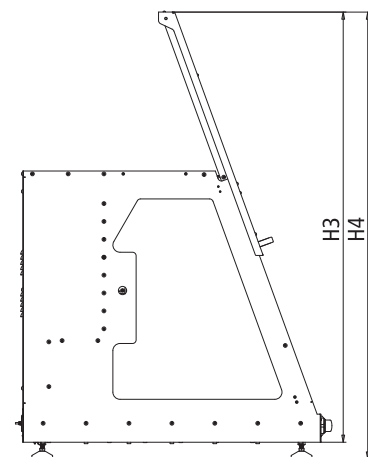
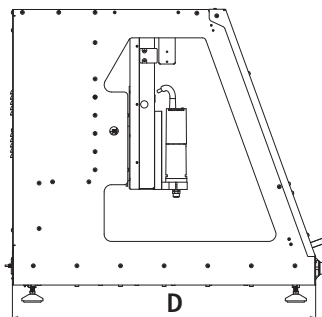
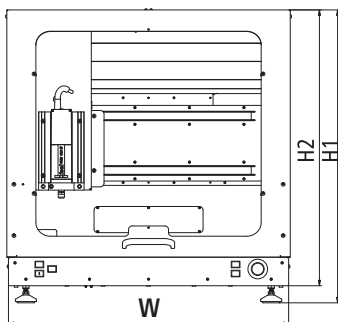

CNC machine

with step motor drive

ICP 4030

General

CNC machines in the ICP series have been developed from the proven CPM series. By introducing a sliding door, the machines can now be operated in a sitting position which, inter alia, leads to shorter cycle times when opening the hood. The chassis is completely bolted instead of being welded like its predecessors. This produces higher precision when building the machine and makes servicing easier. In addition, it was possible to optimise the resonance and vibration behaviour and therefore lower noise build-up has been achieved.

Technical specifications

	ICP 4030
Traverse path X/Y/Z [mm]	400 x 300 x 140
Clamping table surface W × D [mm]	700 x 375
Throughput [mm]	170
Dimensions W × D × H [mm]	780 x 850 x 810
Guides	Linear units with precision steel shafts and recirculating ball slots, clearance free adjustable
Process speed X/Y/Z [mm/s]	100 (for Ball screw drives 16x10) 60 (for Ball screw drives 16x4)
Repeatability [mm/s]	± 0.02
Drive motors	Stepper motors
Drive elements X/Y/Z	Ball screw drives 16 x 10 / 16 x 10 / 16 x 4 mm Clearance free adjustable (optional: 16 x 4 mm in X/Y/Z)
Controller	iMC-P step controller with 4 final stages 48V/4.2A and 500W power supply unit with processor board
Operation	Function keys and emergency shutdown
Software	WinRemote (optional: ProNC, isy CAM 2.8)
Weight [kg]	appr. 120
Part-no.:	280220 7405 *

* The deliverables include an accompanying pack with mechanical accessories (inter alia Hand lever clamping device, stop rails Triangle wrench, open jaw wrench, hook wrench, Allen key, one 6-socket bench extension, connection lead, power lead)

Accessories

280220 9012	Cooling/spray device for ICP 4030
280120 9010	Length measuring button for ICP 4030
280110 9004	Workspace lighting for ICP 4030
420003 0500	Milling motor UFM 500, 500 W, 11,000...25,000 r.p.m.
280110 9001	Suction device for UFM 500
Z13-337070	isy-CAM 2.8
Z11-333500	ProNC software
310704 1631	iSA 500 spindle motor up to 30,000 rpm, 500 W, with frequency converter, CoolMin tool cooling system, ER 11 clamping ring and motor lead
310707 1631	iSA 750 spindle motor up to 24,000 rpm, 750 W, with frequency converter, CoolMin tool cooling system, ER 16 clamping ring and motor lead
280210 9001	Suction device for iSA 500 / 750
280000 0046	Fixing plate for main spindle drive iSA 500 / 750
290055	Vice 1 (W 130 x H 45 x L 152 mm)
290056	Vice 2 (W 180 x H 75 x L 215 mm)

Technical specifications subject to change.

CNC machine

with servo motor drive

ICV 4030



ICV 4030 with improved hodd opening



ICV 4030 closed

Features

- compact entry-level model in the servo area
- low maintenance
- Control with integrated PC controller
- Complete machine under € 10,000

Dimensioned drawings

machine bench

W 1500 D 1000 H 750

Part-no. 248550 0013

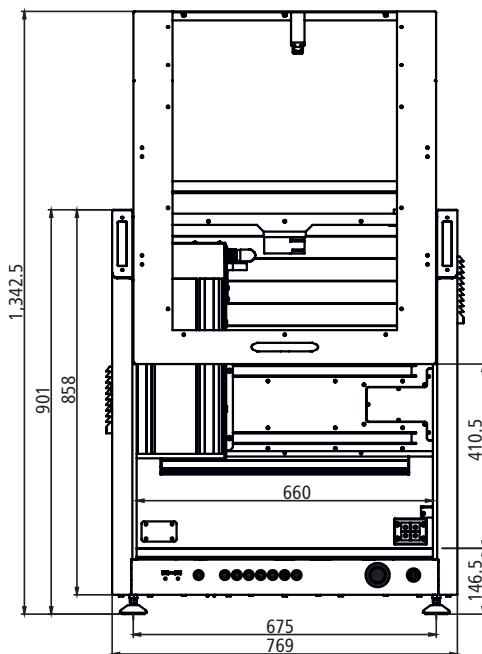

front view

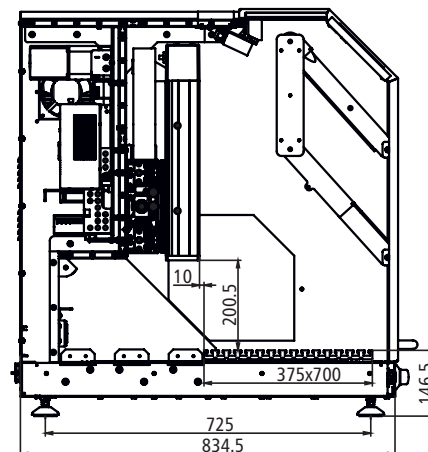

side view

CNC machine

with servo motor drive

ICV 4030

General

Our ready-to-use desktop machine ICV 4030 has been proven for years in practice and will be presented now in a completely new design. The newly designed machine door with improved hood opening allows a longer travel range in the Z-axis, and therefore a higher passage. Due to the redesigned machine hood and the resulting greater access opening, a 4th axis can now be integrated easily. Maintenance-free EC servo motors are used as drive, the reliable linear unit LES 5 is used in the X-axis. Furthermore, the universal control PC iPC 25 is installed. The central lubrication makes the machine overall more service-friendly. Also additional signal lamps were integrated.

Technical specifications

	ICV 4030
Processing areas X/Y/Z [mm]	400 x 300 x 140
Bench clamping area WxD [mm]	700 x 375
Gap [mm]	200
Dimensions WxDxH [mm]	769 x 836 x 901
Guides	linear units with precision steel shafts and ball recirculation carriage, adjustable for no play
Processing speed X/Y/Z [mm/s]	max. 200
Repeat accuracy [mm]	± 0.02
Drive motors	servo motors
Drive elements X/Y/Z	Ball screws 16 x 10 / 16 x 10 / 16 x 5 mm adjustable for no play
Controller	CAN-Controller iMC with 3 drive control modules, integrated controll computer, I/O module, safety circuit and standstill monitoring, power supply 48 V / 1,000 Watt
Operation	function keys and emergency stop
Software	WinRemote (optionally: ProNC, CAD/CAM isy 2.8)
Weight (kg)	approx. 150
Item-No.	280260 0001

Accessories

310704 1631	spindle motor iSA 500 with CoolMin and frequency converter
310707 1631	spindle motor iSA 750 with CoolMin and frequency converter
310709 3612	spindle motor iSA 900 with frequency converter
239170 0001	collets ER 11 for iSA 500 and iSA 900, 13-piece, Ø 1-7 mm
239171 0001	collets ER 16 for iSA 750, 10-piece, Ø 1-10 mm
239011 0053	tool changing station 5-fold linear changer, for SK 11 tool holders
239111 0001	tool holder SK 11 for collets ER 11
280120 9010	length measuring sensor
239012 0000	dust extraction for iSA 500 / 750, opened manually
239012 0004	dust extraction for iSA 900, opening pneumatically
269100 0030	tailstock unit RE-XS for rotary unit RDH-XS
266000 0200	rotation unit RDH-XS, HD transmission U= 1:101, full-wave design, servo drive
269060 4065	three-jaw chucks
216601 0017	vacuum clamping plates VakuFit L, 210 x 150 mm, with hole grid system
290014	clamping elements set, mechanically
Z13-337070	isy-CAM 2.8
Z11-333500	ProNC Software

Technical specifications subject to change.

CNC machine

with servo motor drive

OverHead[®]

Features

- Compact footprint size
- Free floor standing design
- Large open machining area
- High Z-axis clearance for deep tool machining

We offer
FINANCING!



Interesting application videos can be found on our YouTube channel. Just take a look!



OverHead M40
with control panel iOP-19-TFT

Technical specifications

	OverHead M20	OverHead M30	OverHead M40	OverHead M50
Processing areas X/Y/Z [mm]	710 / 610 / 310	710 / 910 / 310	1,210 / 910 / 310	1,210 / 1,410 / 310
Bench clamping area WxD [mm]	1,100 x 1,000	1,100 x 1,300	1,600 x 1,300	1,600 x 1,800
Gap [mm]	340 (590)			
Dimensions WxDxH [mm]	1,400 x 1,200 x 1,960	1,400 x 1,500 x 1,960	1,900 x 1,500 x 1,960	1,900 x 2,000 x 1,960
Processing speed X/Y/Z [mm/s]	250			
Drive motors	EC servo motors			
Drive elements X/Y/Z	Recirculation ball screws 16 x 10 / 16 x 10 / 16 x 5 mm, adjustable for no play			
Controller	iMD CAN controller with 4 drive controllers, expandable to 12 axes (max. 6 interpolated & 6 handling axes), PC, I/O module, safety circuit with rest state monitoring, power supply unit 48 V / 1,000 W			
Operation	control panel iOP-19-TFT			
Weight (kg)	appr. 450 kg			
Software	Windows, WinRemote (optional: ProNC)			
Connection values	400 V / 16 A			
Part-no.	276223 56165E	276233 56165E	276243 56165E	276253 56165E

CNC machine

with servo motor drive

OverHead[®]

Features

- Twin Y-axis gantry fully synchronised with Software ProNC
- CAN-bus control system with brushless servo motors for all axes
- T-slot table top for easy clamping of workpieces and accessories
- Gantry clearance options from 340mm to 590mm
- Maximum spindle motor size iSA 2200
- Linear motion upto 250mm/sec.
- Control panel iOP-19-TFT
- Control PC iPC 25 including PCI card Win 7/64 bit

Options

- cooling spray device
- blade tray
- tool length sensor
- spindle motors (up to iSA2200 applicable)
- Round changing systems SK 11 and SK 20
- Linear changing systems SK 11 and SK 20
- 4th axis with tailstock unit
- 4th + 5th axis as rotary tilting unit
- LED-lighting

Areas of application

- Machining
- Testing and Measuring
- Glue Dispensing

Dimensioned drawings

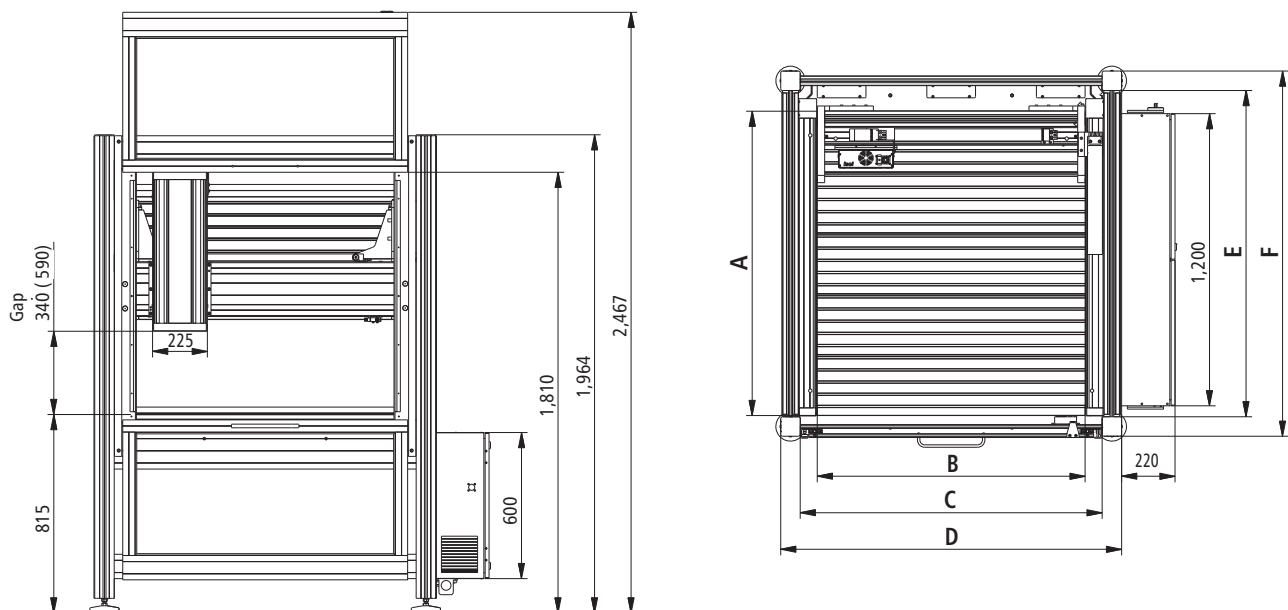

	A	B	C	D	E	F
Gantry OverHead M20	1,000	1,100	1,240	1,400	1,040	1,200
Gantry OverHead M30	1,250	1,100	1,240	1,400	1,340	1,500
Gantry OverHead M40	1,250	1,600	1,740	1,900	1,340	1,500
Gantry OverHead M50	1,750	1,600	1,740	1,900	1,840	2,000

Technical specifications subject to change.

CNC machine

with servo motor drive

EUROMod®

Features

- Space-saving
- fixed portal, moving bench
- 5-axis machining
- also available with gantry drive

We offer
FINANCING!



Interesting application videos can be found on our YouTube channel. Just take a look!



EuroMod MP 65
with control panel iOP-19-TFT
and closed sliding door

Technical specifications

	EUROMod® MP 30	EUROMod® MP 45	EUROMod® MP 65
Processing areas X/Y/Z [mm] *	650 / 300 / 250	650 / 450 / 250	1,000 / 650 / 250
Bench clamping area W × D [mm]	900 x 350	900 x 500	1,200 x 700
Gap [mm] *	350		
Dimensions WxDxH [mm]	1,160 x 800 x 1,960	1,160 x 1,110 x 1,960	1,480 x 1,510 x 1,960
Processing speed X/Y/Z	max. 250 mm/s		
Repeat accuracy [mm]	± 0.02		
Drive motors	Servo motos		
Drive elements X/Y/Z	Recirculating ball drive, adjustable for no play		
Controller	iMD CAN controller with 3 or 4 drive controllers, expandable to 12 axes (max. 6 interpolated & 6 handling axes), PC, I/O module, safety circuit with rest state monitoring, power supply unit 48V/1000 W		
Operation	Control panel iOP-19-TFT		
Weight (kg)	approx. 275	approx. 300	approx. 400
Software	Windows, WinRemote (optional: ProNC, isy 2.8)		
Connection values	230V, 16A		
Part no.	276133 53655E	276143 53655E	276153 73655E

* without mounted components on the axes !

CNC machine

with servo motor drive

EUROMod®

Features

- Portal gap: 350mm
- Maintenance-free servo motors
- Maximum spindle motor size up to 1.5 kW
- Available with or without protective hood
- Ideal for multi-shift operation
- Control panel iOP-19-TFT
- Control PC iPC 25 including PCI card Win 7/64 bit

Areas of applications

For the machining of:

- Light metals
- Plastics
- Wood
- Foams
- Plexiglas

Options

- PC control console with free PCI plug-ins (for use by external PCI hardware)
- Stainless steel keyboard
- Safety light curtain
- Milling and engraving spindles
- SK11/SK20 automatic tool change stations
- Minimum quantity lubrication or CoolMin cooling system
- Vacuum clamping benches
- Suction device
- 4th axis e. g. RDH series installation
- pneumatic sliding door

Dimensioned drawings

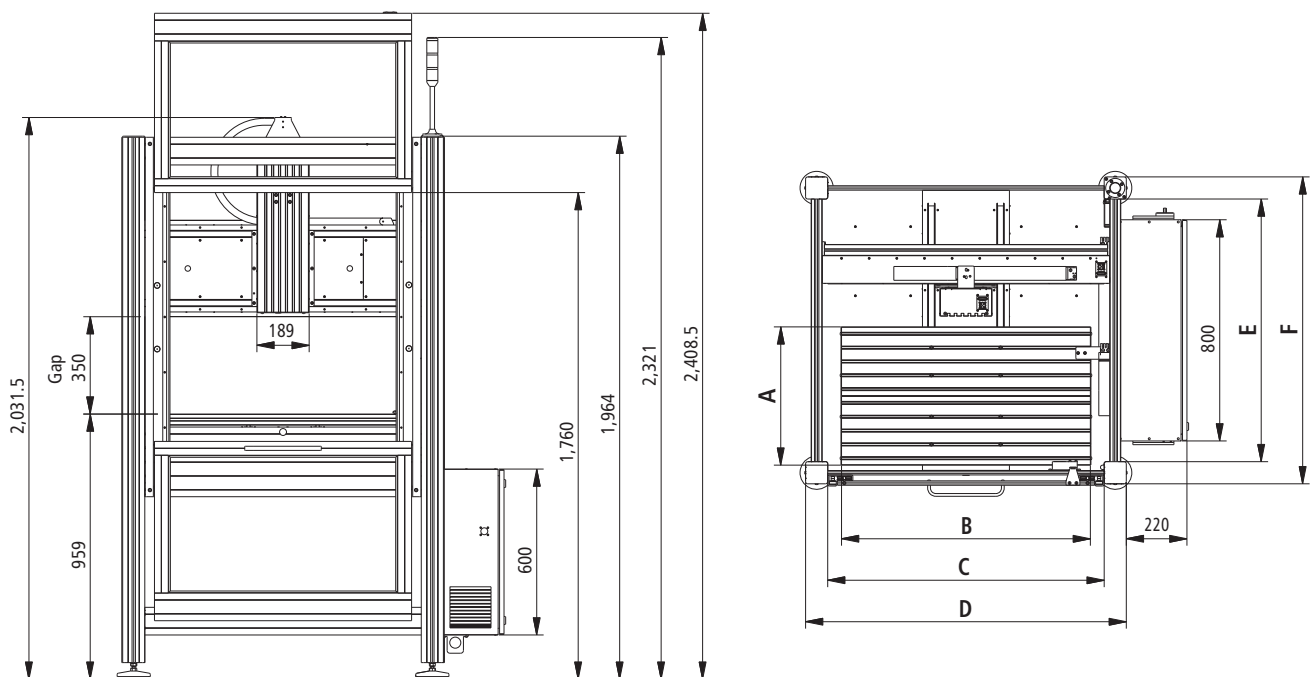

	A	B	C	D	E	F
EuroMod MP30	350	900	1,000	1,160	640	800
EuroMod MP45	500	900	1,000	1,160	950	1,110
EuroMod MP65	700	1,200	1,200	1,480	1,350	1,510

Technical specifications subject to change.

CNC machine

with servo motor drive

FLATCom[®]
M series

We offer
FINANCING!

Features

- 5-axis machining
- moving portal,
fixed bench
- maintenance-free motors



Interesting application videos can be found on our YouTube channel. Just take a look!



FlatCom M 40

with open hood and options: spindle motor, tool changer, VakuFit vacuum clamping plate, length measuring key, CoolMin tool cooling, CNC joystick

Technical specifications

	FLATCom [®] M 20	FLATCom [®] M30	FLATCom [®] M40	FLATCom [®] M50
Processing areas X/Y [mm] *	700 / 600	700 / 900	1,200 / 900	1,200 / 1,400
Z lift [mm]	150 (optional 250, in each case without processing unit)			
Bench clamping area W x D [mm]	750 x 750	750 x 1,000	1,250 x 1,000	1,250 x 1,500
Z gap [mm] *	200 (optional 300, in each case without processing unit)			
Dimensions WxDxH [mm]	1,420 x 1,150 x 1,870	1,420 x 1,450 x 1,870	1,920 x 1,450 x 1,870	1,920 x 1,950 x 1,870
Processing speed X/Y/Z	max. 250 mm/s			
Repeat accuracy [mm]	± 0.02			
Drive motors	Servo motors			
Drive elements X/Y/Z	Recirculating ball drive, adjustable for no play			
Controller	iMD CAN controller with 3 drive controllers, expandable to 12 axes (max. 6 interpolated & 6 handling axes), PC, I/O module, safety circuit with rest state monitoring, power supply unit 48 V / 1000 W			
Operation	Control panel iOP-19-TFT			
Weight (kg)	approx. 300	approx. 340	approx. 450	approx. 525
Software	Windows, WinRemote (optional: ProNC, isy 2.8)			
Connection values	230V, 16A		400V, 16A	
Part-no. (Z lift = 150 mm)	276023 52455E	276033 52455E	276043 52455E	276053 52455E
Part-no. (Z lift = 250 mm)	276023 53455E	276033 53455E	276043 53455E	276053 53455E

* without mounted components on the axes !

CNC machine

with servo motor drive

FLATCom[®]

M series

Features

- Portal gap: 200mm, optional 300mm
- Maintenance-free servo motors
- Maximum spindle motor size up to 1.5 kW
- Available with or without protective hood
- Ideal for multi-shift operation
- Control panel iOP-19-TFT
- Control PC IPC 25 including PCI card Win 7/64 bit

Areas of applications

For the machining of:

- Plastics
- Wood
- Foams
- Plexiglas

Options

- PC control console with free PCI plug-ins (for use by external PCI hardware)
- Safety light curtain
- Milling and engraving spindles
- SK11/SK20 automatic tool change stations
- Minimum quantity lubrication or CoolMin cooling system
- Vacuum clamping benches
- Suction device
- 4th axis e. g. RDH series installation
- Version without hood
- Maximum 6 interpolated axes + 6 handling axes
- Portal gap 300 mm
- Pneumatic sliding door

Dimensioned drawings

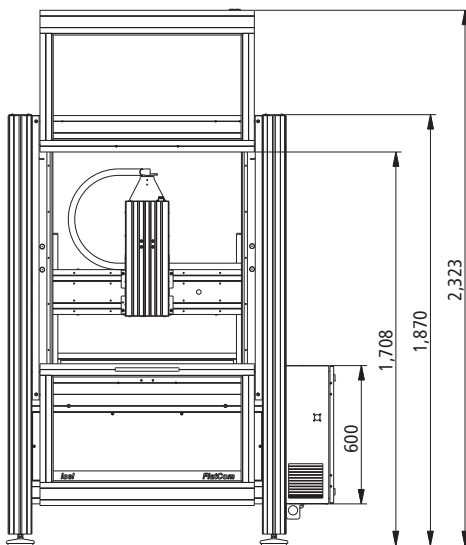

FlatCom with sub-frame and hood

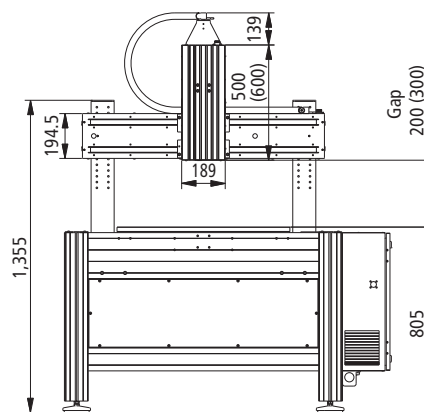

FlatCom with sub-frame and without hood

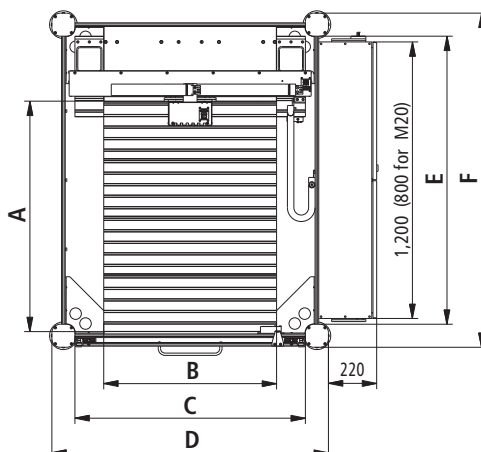

	A	B	C	D	E	F
FlatCom M20	750	750	1,000	1,200	950	1,150
FlatCom M30	1,000	750	1,000	1,200	1,250	1,450
FlatCom M40	1,000	1,250	1,500	1,700	1,250	1,450
FlatCom M50	1,500	1,250	1,500	1,700	1,750	1,950

Technical specifications subject to change.

CNC machine

with servo motor drive

FLATCom[®]
L series



Features

- 5-axis machining
- Large processing surface up to 1700 x 2500 mm
- Gantry drive
- Mobile portal, fixed bench
- removeable hood



Interesting application videos can be found on our YouTube channel. Just take a look!

FlatCom L250 with iOP-19-CPU

Technical specifications

	FLATCom [®] L150	FLATCom [®] L250
Processing areas X/Y [mm] *	1,500 / 1,700	2,500 / 1,700
Z lift [mm]	210	
Bench clamping area WxD [mm]	1,600 x 2,250	2,600 x 2,250
Z gap [mm] *	270	
Dimensions WxDxH [mm]	2,216 x 2,430 x 1,995	3,216 x 2,430 x 1,995
Processing speed X/Y/Z	max. 250 mm/s	
Repeat accuracy [mm]	± 0.02	
Drive motors	Servo motors	
Drive elements X/Y/Z	Recirculating ball drive, adjustable for no play	
Controller	IMD CAN controller with 4 drive controllers, expandable to 12 axes (max. 6 interpolated & 6 handling axes), PC, I/O module, safety circuit with rest state monitoring, power supply unit 48V / 1000W	
Operation	Control pult iOP-19-CPU	
Weight [kg]	appr. 435	appr. 510
Software	Windows, WinRemote (optional: ProNC, isy 2.8)	
Connection values	400 V, 16 A	
Part-no.	276063 34565E	276073 34565E

* without mounted components on the axes !

CNC machine

with servo motor drive

FLATCom[®]

Features

- Portal gap: 300mm
- Maintenance-free servo motors
- Particularly suitable for the whopping editing (aluminium, non-ferrous metals, ceramics etc...)
- Installation of spindle motors up to 3.6 KW, SK 30 tool holders
- Available with or without protective hood
- Ideal for multi-shift operation
- Control pult iOP-19-CPU
- Control PC iPC 25 including PCI card Win 7 / 64 bit

Areas of applications

For the machining of:

- Light metals
- non-ferrous metals (brass, bronze etc...)
- CFRP
- Ceramic
- Plastics
- Wood

Options

- PC control console with free PCI plug-ins (for use by external PCI hardware)
- Safety light curtain
- Milling and engraving spindles
- SK11/SK20 automatic tool change stations
- Minimum quantity lubrication or CoolMin cooling system
- Vacuum clamping benches
- Suction device
- 4th axis e. g. RDH series installation
- Version without hood
- Maximum 6 interpolated axes + 6 handling axes
- Portal gap according to customers request

Dimensioned drawings

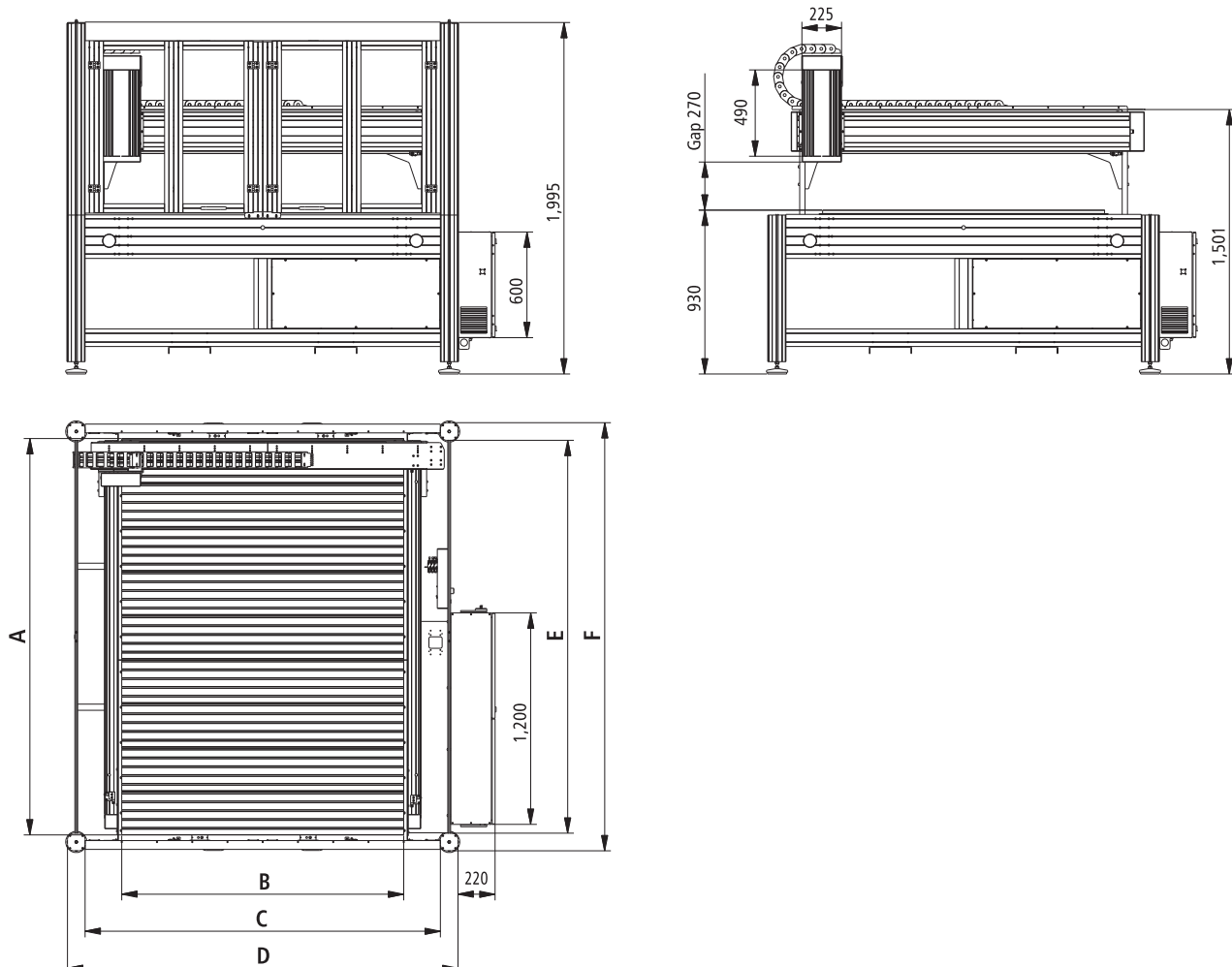

Technical specifications subject to change.

CNC machine

with servo motor drive

FLATCom[®]
XL series



Features

- Windows-based software
- Gantry drive
- Mobile portal, fixed bench



FlatCom XL with control pult iOP-19

Interesting application videos can be found on our YouTube channel. Just take a look!

Technical specifications

	FLATCom [®] 102/72	FLATCom [®] 102/112	FLATCom [®] 142/112	FLATCom [®] 142/162	FLATCom [®] 142/252
Processing areas X/Y [mm] *	1,020 / 720	1,020 / 1,120	1,420 / 1,120	1,420 / 1,620	1,420 / 2,520
Z lift [mm]	210 (optional: 410, in each case without processing unit)				
Bench clamping area W x D [mm]	1,125 x 1,300	1,125 x 1,700	1,500 x 1,700	1,500 x 2,200	1,500 x 3,050
Z gap [mm] *	235 (optional 435, in each case without processing unit)				
Dimensions WxDxH [mm]	2,084/1,584/1,990	2,084/1,984/1,990	2,459/1,984/1,990	2,459/2,484/1,990	2,459/3,384/1,990
Processing speed X/Y/Z	max. 250				
Repeat accuracy [mm]	± 0.02				
Drive motors	Servo motors				
Drive elements X/Y/Z	Recirculating ball drive, adjustable for no play				
Controller	iMD CAN controller with 4 drive controllers, expandable to 12 axes (max. 6 interpolated & 6 handling axes), PC, I/O module, safety circuit with rest state monitoring, power supply unit 48V/1000 W				
Operation	Control pult iOP-19-CPU				
Weight [kg]	approx. 550	approx. 600	approx. 700	approx. 800	approx. 1000
Software	Windows, WinRemote (optional: ProNC, isy 2.8)				
Connection values	400 V, 16 A				
Part-no. (Z lift = 210 mm)	276552 0013E	276553 0013E	276554 0013E	276555 0013E	276556 0013E

* without mounted components on the axes !

CNC machine

with servo motor drive

FLATCom[®]

XL series

Features

- Portal gap: 235mm optional 435mm (for bigger workpieces)
- Maintenance-free servo motors
- Particularly suitable for the whopping editing (aluminium, non-ferrous metals, ceramics etc...)
- Installation of spindle motors up to 3.6 KW, SK 30 tool holders
- Available with or without protective hood
- Ideal for multi-shift operation
- Control pult iOP-19-CPU
- Control PC iPC 25 including PCI card Win 7/64 bit

Areas of applications

For the machining of:

- Light metals
- non-ferrous metals (brass, bronze etc...)
- CFRP
- Ceramic
- Plastics
- Wood

Options

- PC control console with free PCI plug-ins (for use by external PCI hardware)
- Safety light curtain
- Milling and engraving spindles
- SK11/SK20 automatic tool change stations
- Minimum quantity lubrication or CoolMin cooling system
- Vacuum clamping benches
- Suction device
- 4th axis e. g. RDH series installation
- Version without hood
- Maximum 6 interpolated axes + 6 handling axes
- Portal gap 435 mm

Dimensioned drawings

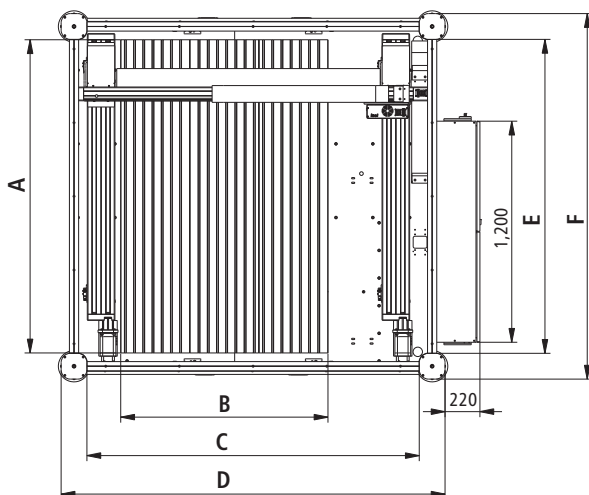
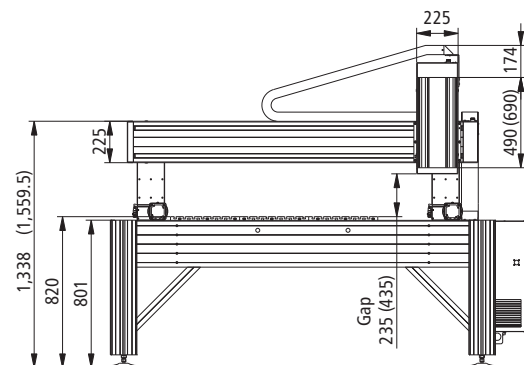
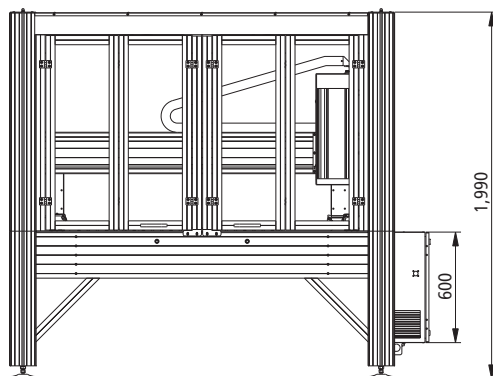

	A	B	C	D	E	F
FlatCom XL 102/72	1,300	1,125	1,804	2,084	1,304	1,584
FlatCom XL 102/112	1,700	1,125	1,804	2,084	1,704	1,984
FlatCom XL 142/112	1,700	1,500	2,179	2,459	1,704	1,984
FlatCom XL 142/162	2,200	1,500	2,179	2,459	2,204	2,484
FlatCom XL 142/252	3,050	1,500	2,179	2,459	3,100	3,380

Technical specifications subject to change.

Flat bed units



Flat bed unit with Z-axis



Flat bed unit with Z-axis and underframe



Flat bed unit with Z-axis, underframe and housing

General note

Flatbed units as defined in the machine guidelines as incomplete machines according to the modular system with processing paths of 250 to 1250 mm. Step motors (MS200HT), set for no-play, are used as spindle drives. Recirculating ball drives with a repeatability of ± 0.02 mm (positioning reproducibility) are used. The linear guides used are the isel double track feeds, proven over many years, with no-play pre-stressed linear ball bearings and recirculating ball spindles with a repeatability of ± 0.02 mm. All units are equipped with two limit switches per spindle. The machining and positioning units are available in a number of versions and are characterised by smooth running and high process speeds. The use of high quality aluminium components with flat-milled surfaces achieves low weight and high accuracy. isel X/Y/Z units are the ideal basis for setting up machines and systems for fitting and assembling, pressing and engraving, drilling and milling, milling and screwing, shaping and modelling, bonding and casting, soldering and welding, measuring and checking, sawing and cutting, etc.

Ordering information

X/Y flatbed units FB2

Part no.	Chassis A x B (mm)	Clamping surface X x Y (mm)	process travel X x Y (mm)	Z gap (mm)
246203M	1,210 x 946	750 x 850	530 x 500	190
246203 2040M	1,210 x 1,196	750 x 1,100	530 x 750	
246203 2054M	1,210 x 1,446	750 x 1,350	530 x 1,000	
246203 2067M	1,460 x 1,446	1,000 x 1,350	780 x 850	
246203 2130M	1,710 x 1,846	1,250 x 1,750	1,030 x 1250	

All flatbed units are fitted with **16 x 4 mm recirculating ball** drives as standard

Z-axes for flatbed units

Part no.	Lift (mm)	
230514M	75	with magnet brake 24 V
230514 0400M	160	with magnet brake 24 V

Underframes

Part no.	suitable for flatbed unit With clamping surface:
248500 0027	750 x 850
248500 0040	750 x 1,100
248500 0054	750 x 1,350
248500 0067	1,000 x 1,350
248500 0130	1,250 x 1,750

Housings

Part no.	suitable for flatbed units with clamping surface:
248200 0000	750 x 850
248200 2040	750 x 1,100
248200 2054	750 x 1,350
248200 2067	1,000 x 1,350
248200 2130	1,250 x 1,750

Flat bed units

Options

- Appropriate Controller (e.g.: iMC-S8)
- Software modules for operating in CAM, CNC and SPS applications
- Underframe
- Housing
- Spindle motors (see pages E-22 et seq.)
- Gap: 300 and 500 mm respectively

Accessories

Part no.	
219200 0001	Energy guidance chain

Software

Part-no.	
Z11 - 333 500	ProNC Software
Z13 - 337 070	isy-CAM 2.8

Dimensioned drawings

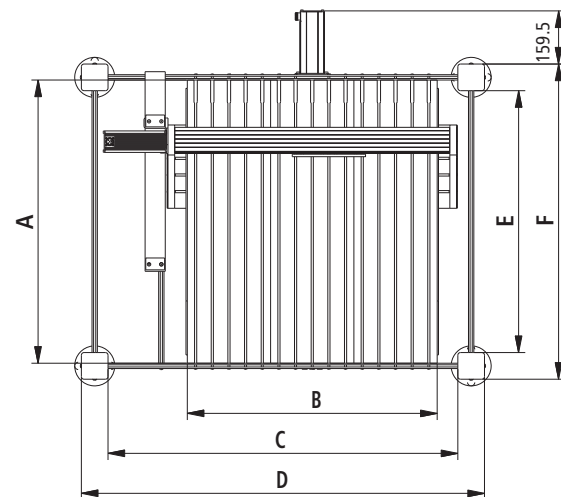
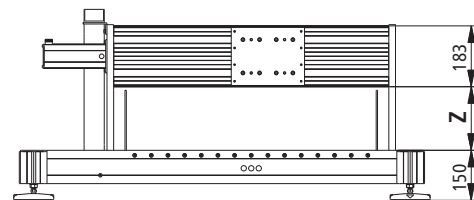
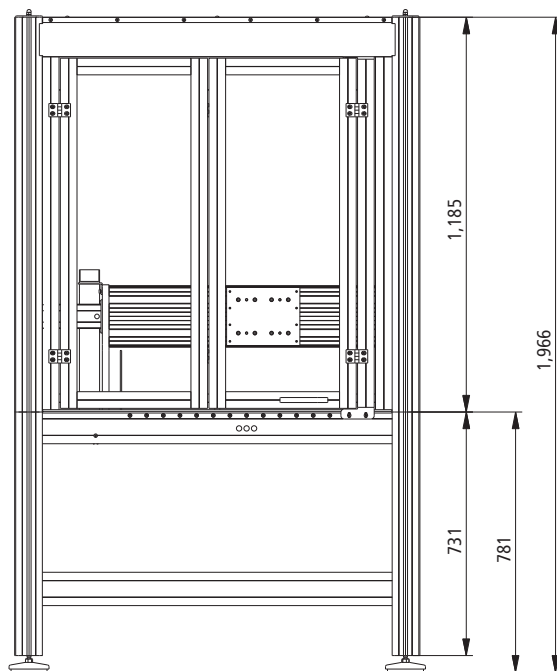

Part-no.	Travel [mm]		Bench clamping area						
	X	Y	A	B	C	D	E	F	Z
246203M	530	500	850	750	1,050	1,210	786	946	190
246203 2040M	530	750	1,100	750	1,050	1,210	1,036	1,196	
246203 2054M	530	1,000	1,350	750	1,050	1,210	1,286	1,446	
246203 2067M	780	850	1,350	1,000	1,300	1,460	1,286	1,446	
246203 2130M	1,030	1,250	1,750	1,250	1,550	1,710	1,686	1,846	

Technical specifications subject to change.

Introduction

When developing our spindle motors, our main emphasis was on functionality, quality, and the optimum price structure. Our spindle motors are also particularly easy to maintain. The particularly slim lines and square housing cross-section allow installation in rows with minimum separation.

Our approach to electrical construction is to use an AC short circuit rotor with 2-pole windings in our motors, designed to DIN EN 60034. The insulation of the windings is produced according to heat class F. The motors are dynamically balanced to very fine tolerances, so that good running properties are achieved even at high speeds. In all, they cover a range of speeds from 3,000 to 30,000 rpm. All spindle motors are produced entirely in Germany, meet at least the criteria for IP54 protection class and are therefore approved even for areas where wood dust is present. In our product portfolio, in addition to spindle motors, you'll find all the leads you will need in various lengths and preset, reliable frequency converters for connecting to the controller.

By integrating development, production, sales and service under one roof, we have very short procedures and have our own repair service which operates year-round, unlike many of our competitors. An extensive range of accessories, such as vacuum cleaning systems, minimum amount greasing systems, collets, SK housings, tool changers and our unique, patented Coolmin system for optimum and economical tool cooling, without residues, round off our product portfolio.



■ iSA 500 with manual tool changer	■ E-23
■ iSA 750 with manual tool changer	■ E-24
■ iSA 1500 with manual tool changer	■ E-25
■ iSA 1500 L with manual tool changer	■ E-26
■ iSA 900 with automatic tool changer	■ E-27
■ iSA 2200 with automatic tool changer	■ E-28
■ iSA 1500WL with automatic tool changer	■ E-29
■ iSA 3600 with automatic tool changer	■ E-30
■ iSA 1500 W with automatic tool changer	■ E-31
■ Universal milling spindles UFM 500 /1050, Engraving spindle	■ E-32
■ High frequency spindles HFS 800 / 2200	■ E-33
■ Extraction devices	■ E-34
■ CoolMin tool cooling system	■ E-36
■ Linear tool change stations SK 11 / 20 / 30	■ E-38
■ Turned tool change stations SK 11 / 20	■ E-40
■ Frequency converter, Length measuring sensor, vacuum cleaning, motor leads	■ E-41
■ Overview of collets, tool holders, milling boxes	■ E-42
■ Vacuum clamping plates	■ E-43

Technical specifications subject to change.

Spindle motor

with manual tool changer

iSA 500



Features

- Robust 2-pole AC motor (asynchronous motor)
- Square shape, protection class IP54, isolation class F
- Cast bearing apron A-side, aluminium extrusion B-side
- Motor shaft to take ER 11 collets
- Rated output 0.5 kW (S6-40% operation)
- Speed range 5,000 rpm. - 30,000 rpm.
- Manual tool change
- M23 plug connection
- incl. ER 11 collet, \varnothing 6 mm
- Clamping range \varnothing 1 mm – \varnothing 7 mm
- Intrinsic ventilation B-side
- Controlled by Frequency converter
- Spindle bearing: 2 bearings A-side
1 bearing B-side
- **Optional:**
 - CoolMin[®] (internal and external)
 - Frequency converter
 - Various collets, mounting plates, lead lengths
 - Suction device

Technical specification

Description		iSA 500
Torque at rated speed 18,000 rpm	[Nm]	0.28
Speed	[rpm]	5,000 to 30,000
Cut-off frequency	[Hz]	300
Number of poles		2
Rated voltage	[V]	230
Rated current	[A]	2.6
cos ϕ		0.75
S 6 = 40% rated output	[kW]	0.5
Concentricity	[mm]	0.01
Weight	[kg]	2.8

Dimensioned drawings

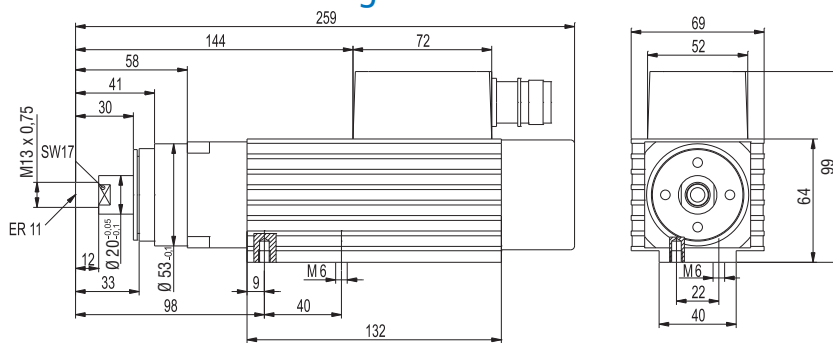

Torque curves

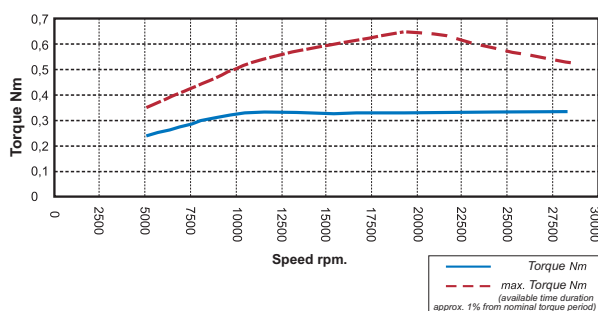

Technical specifications subject to change.

Ordering information

iSA 500 spindle motor
Part no.: **477004 3130**

iSA 500 spindle motor
with converter and lead (8m)
Part no.: **310704 1611**

iSA 500 spindle motor with CoolMin[®]
Part no.: **477004 5130**

iSA 500 spindle motor with converter,
lead (8 m) and CoolMin[®]
Part no.: **310704 1631**

LES 5 mounting plate
Part no.: **277014**

LES 6 / FB 2 mounting plate
Part no.: **277028 0008 / 277013**

ICP/ICV mounting plate
Part no.: **280000 0046**

EuroMod/FlatCom mounting plate
Part no.: **277028**

- SKC 750 frequency converter see page **E-41**
- M23 motor side leads see page **E-41**
- Suction device for 38 mm hose see page **E-41**
- collet set, ER11 type see page **E-42**

Spindle motor with manual tool changer

iSA 750



Features

- Robust 2-pole AC motor (asynchronous motor)
- Square shape, Protection class IP54, insulation class F
- Aluminium extrusion A and B sides
- Motor shaft to take ER 16 collets
- Rated output 0.75 kW (S6-40% operation)
- Speed range 3,000 rpm. - 24,000 rpm.
- Manual tool change
- M23 plug connection
- Incl. ER16 collet, Ø 6 mm
- Clamping range Ø 1 mm – Ø 10 mm
- Intrinsic ventilation B-side
- Two precision bearings
- Controlled by frequency converter
- optional:
 - CoolMin® (internal and external)
 - Frequency converter
 - Various collets, mounting plates, lead lengths
 - Suction device

Technical specification

Description		iSA 750
Torque at rated speed 22,000 rpm	[Nm]	0.34
Speed	[rpm]	3,000 to 24,000
Cut-off frequency	[Hz]	300
Number of poles		2
Rated voltage	[V]	230
Rated current	[A]	3.4
cos φ		0.79
S 6 = 40% rated output	[kW]	0.75
Concentricity	[mm]	0.01
Weight	[kg]	2.6

Dimensioned drawings

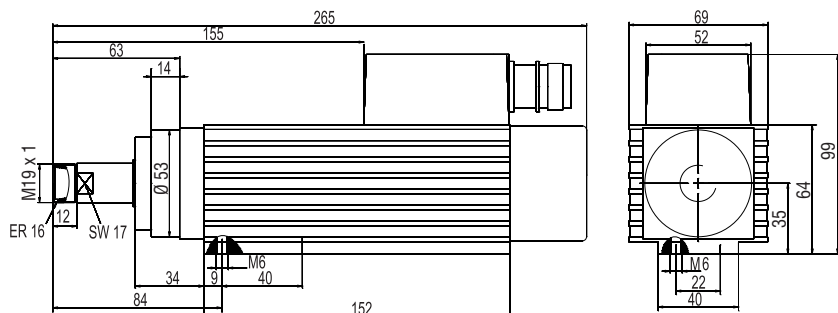

Torque curves

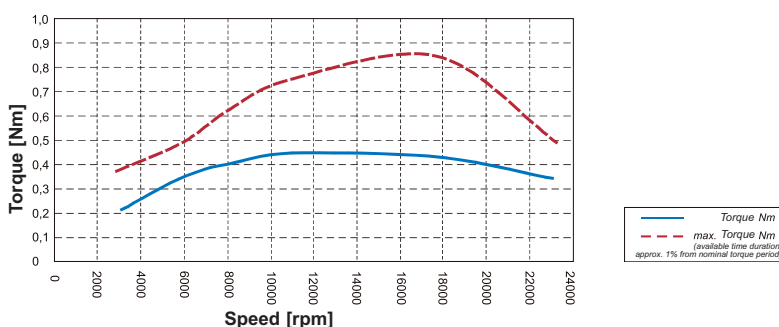

Ordering information

iSA 750 spindle motor
Part no.: **477008 3124**

iSA 750 spindle motor
with converter and lead (8 m)
Part no.: **310708 1611**

iSA 750 spindle motor with CoolMin®
Part no.: **477008 5124**

iSA 750 spindle motor with converter,
lead (8 m) and CoolMin®
Part no.: **310707 1631**

LES 5 / FB 2 mounting plate
Part no.: **277014 / 277013**

LES 6 mounting plate
Part no.: **277028 0008**

ICP/ICV mounting plate
Part no.: **280000 0046**

EuroMod/FlatCom mounting plate
Part no.: **277028**

- SKC 750 frequency converter see page **E-41**
- M23 motor side leads see page **E-41**
- Suction device for 38 mm hose see page **E-41**
- collet set, ER16 type see page **E-42**

Technical specifications subject to change.

Spindle motor with manual tool changer

iSA 1500

Features

- Robust 2-pole AC motor (asynchronous motor)
- Square shape, protection class IP54, insulation class F
- Cast bearing apron A and B sides
- Motor shaft to take ER 20 collets
- Rated output 1.5 kW (S6-40% operation)
- Speed range 5,000 rpm. - 20,000 rpm.
- Manual tool change
- M23 plug connection
- Incl. ER20 collet, Ø 6 mm
- Clamping range Ø 2 mm – Ø 13 mm
- Intrinsic ventilation B-side
- Controlled by frequency converter
- Spindle bearing: 2 bearings A-side
1 bearing B-side

optional:

- CoolMin® (internal and external)
- Frequency converter
- Various collets, mounting plates, lead lengths
- Suction device
- 4-pole motor version to order

Ordering information

iSA 1500 spindle motor
Part no.: **477510 3120**

iSA 1500 spindle motor with converter and connecting lead (8 m)
Part no.: **310610 3614**

iSA 1500 spindle motor with CoolMin®
Part no.: **477510 5120**

iSA 1500 spindle motor with converter and CoolMin®
Part no.: **310610 3634**

LES 5 mounting plate
Part no.: **277028 0003**

EuroMod/FlatCom mounting plate
Part no.: **277028 0002**

- CoolMin® external with hose see page **E-36**
- SKC 1500 frequency converter see page **E-41**
- M23 motor side connecting leads see page **E-41**
- Suction device for 80 mm hose see page **E-41**
- collet set, ER20 type see page **E-42**

iSA 1500 with manual tool change



iSA 1500 with manual tool change and CoolMin tool **cooling system**

Technical specification

Description		iSA 1500
Torque at rated speed 20,000 rpm	[Nm]	0.72
Speed	[rpm]	5,000 to 20,000
Cut-off frequency	[Hz]	300
Number of poles		2
Rated voltage	[V]	230
Rated current	[A]	7
cos ϕ		0.85
S 6 = 40% rated output	[kW]	1.5
Concentricity	[mm]	0.01
Weight	[kg]	6.4

Dimensioned drawings

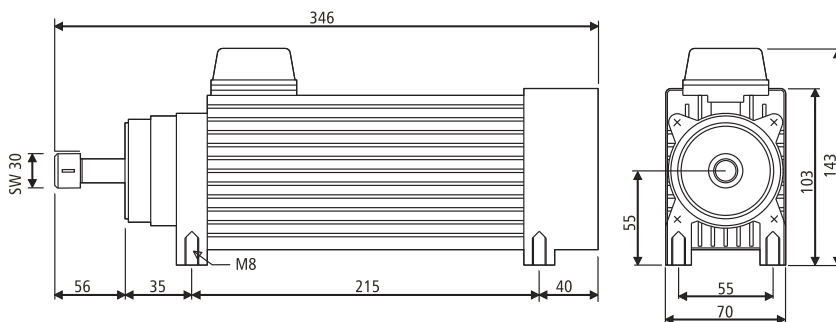

Torque curves

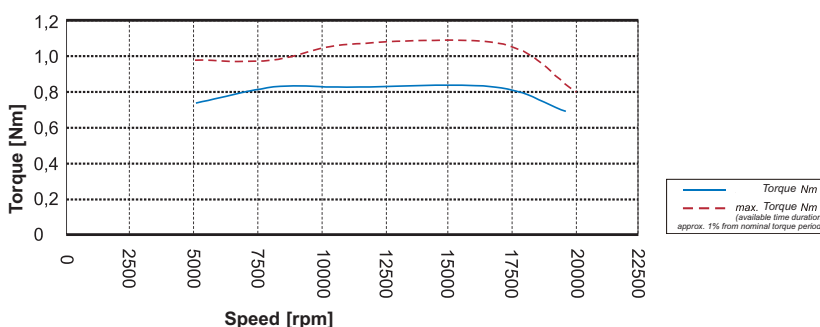

Technical specifications subject to change.

Spindle motor

with manual tool changer

iSA 1500 L



iSA 1500 L with manual tool change

Features

- Robust 2-pole AC motor
- Protection class IP54, insulation class F
- Motor shaft to take ER 20 collets
- Cast bearing apron A and B sides
- Rated output 1.5 kW (S6-40% operation)
- Rotational speed range 2,500 rpm – 6,000 rpm
- Torque 2.37 Nm (at 6,000 rpm)
- Rated voltage 200 V
- Manual tool change
- Clamping range \varnothing 2 mm – \varnothing 13 mm
- Intrinsic ventilation B-side
- Controlled by frequency converter
- Spindle bearing:
 - A-side (milling side) double,
 - B-side (ventilation side) single
- Concentricity: 0.01 mm
- Weight: 10.5 kg
- **Optional:**
 - CoolMin® Tool and material cooling, external
 - Frequency converter
 - collets

Technical specification

Description		iSA 1500 L
Torque at rated speed 6,000 rpm	[Nm]	2.37
Speed range	[rpm]	2,500 to 6,000
Cut-off frequency	[Hz]	107
Number of poles		2
Rated voltage	[V]	200
Rated current	[A]	6.5
cos ϕ		0.84
Rated power (S 6 = 40% operation)	[W]	1500
Concentricity	[mm]	0.01
Weight	[kg]	10.5

Dimensioned drawings

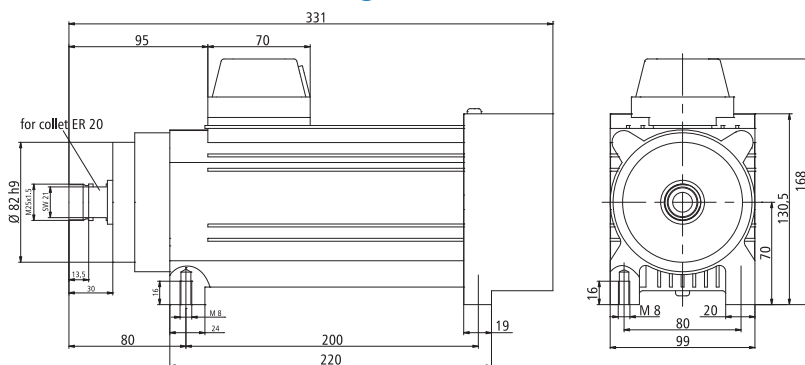

Torque curves

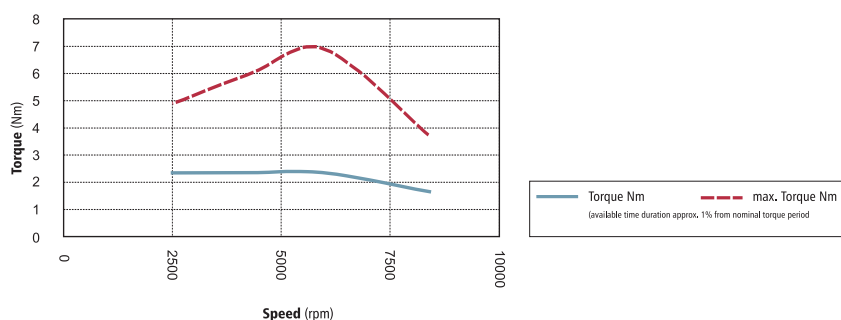

Ordering information

iSA 1500 L spindle motor with collet ER 20 (6 mm), clamping key ER 20, jaw key SW 22, Interconnectron connection

Part no.: **477510 3106**

iSA 1500 L spindle motor with converter with collet ER 20 (6 mm), clamping key ER 20, jaw key SW 22, Interconnectron connection

Connecting leads 8 m

Part no.: **310610 3615**

CoolMin® external

Part no.: **239011 0119**

Suction device for EuroMod / FlatCom prepared for 38 mm diameter hose

Part no.: **239012 0001**

Clamping set ER 20

2.0 / 3.0 / 4.0 / 5.0 / 6.0 / 7.0 / 8.0 / 9.0 / 10.0 / 11.0 / 12.0 / 13.0 mm

Part no.: **239172 0001**

Mounting plate isel System (Z axis)

EuroMod / FlatCom (LES 21)

Part no.: **277028 0011**

Mounting plate isel System (Z axis)

Linear unit LES 5

Part no.: **277028 0005**

Spindle motor

with automatic tool changer

iSA 900



iSA 900 with automatic tool change

Features

- Robust 2-pole AC motor (asynchronous motor)
- Square shape, Protection class IP55, insulation class F
- Cast bearing apron A and B sides
- Rated output 0.9 kW (S6-40% operation)
- Speed range 6,000 rpm. - 24,000 rpm.
- Automatic tool change with SK 11 tool holder and ER 11 collet, Ø 6 mm
- M23 plug connection
- Clamping range Ø 1 mm – Ø 7 mm
- Separately driven fan B-side
- Controlled by frequency converter
- Two precision bearings
- SK 11 tool changer, pneumatic (7.5 bars)
- **Optional:**
 - CoolMin® (external)
 - Frequency converter
 - Tool changing station
 - Various collets, mounting plates, lead lengths

Technical specification

Description		iSA 900
Torque at rated speed 18,000 rpm	[Nm]	0.37
Speed	[rpm]	6,000 to 24,000
Cut-off frequency	[Hz]	400
Number of poles		2
Rated voltage	[V]	230
Rated current	[A]	3.25
cos φ		0.84
S 6 = 40% rated output	[kW]	0.9
Concentricity	[mm]	0.01
Weight	[kg]	5.8

Dimensioned drawings

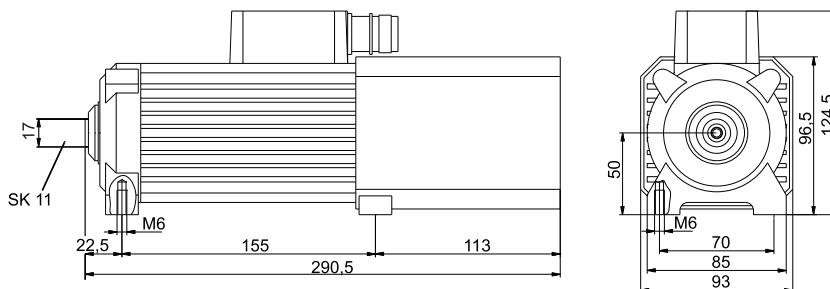

Torque curves

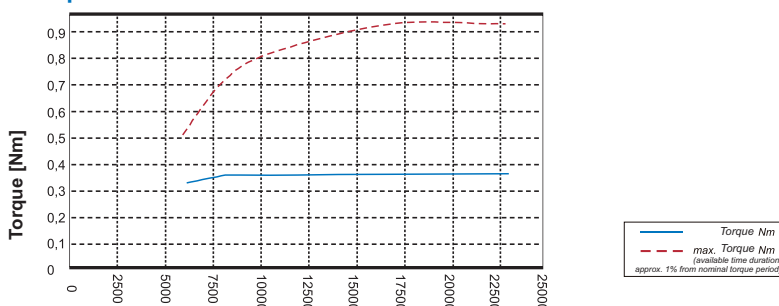

Technical specifications subject to change.

Ordering information

iSA 900 spindle motor
Part no.: **477009 3324**

iSA 900 spindle motor
with converter and lead (8m)
Part no.: **310709 3612**

LES 5/EuroMod/FlatCom mounting plate
Part no.: **277028 0003**

- Cooling system® external with hose see pages **E-36**
- 5 × SK 11 tool change stations see pages **E-38**
- 8 × SK 11 tool change stations see pages **E-38**
- SK 11 tool holder see pages **E-38**
- SKC 750 frequency converter see pages **E-41**
- M23 motor side connecting leads see pages **E-41**
- collet set, ER11 type see pages **E-42**

Spindle motor

with automatic tool changer

iSA 2200



iSA 2200 with automatic tool change

iSA 2200 with CoolMin® for internal tool cooling

Features

- Robust 2-pole AC motor
- Protection class IP55, insulation class F
- Cast bearing apron A and B sides
- Rated output 2.2 kW (S6-40% operation)
- Rotational speed range 5,000 rpm – 20,000 rpm
- Torque 1.26 Nm (at 18,000 rpm)
- Rated voltage 3 x 230 V
- Automatic tool change
- Clamping range Ø 2 – Ø 13 mm
- Separately driven fan B-side
- Controlled by frequency converter
- Two precision bearings
- SK 20 tool changer, pneumatic (7.5 bars)
- Concentricity: 0.01 mm
- Weight: 14.6 kg
- Optional:
 - CoolMin® Tool and material cooling, external
 - CoolMin® internal with **internal tool cooling**
 - Frequency converter
 - Tool changer, collets

Technical specification

Description		iSA 2200
Torque at rated speed 18,000 rpm.	[Nm]	1.26
Speed range	[rpm]	5,000 to 20,000
Cut-off frequency	[Hz]	280
Number of poles		2
Rated voltage	[V]	3 x 230
Rated current	[A]	7.6
cos φ		0.84
Rated power (S 6 = 40% operation)	[W]	2.2
Concentricity	[mm]	0.01
Weight	[kg]	14.6

Dimensioned drawings

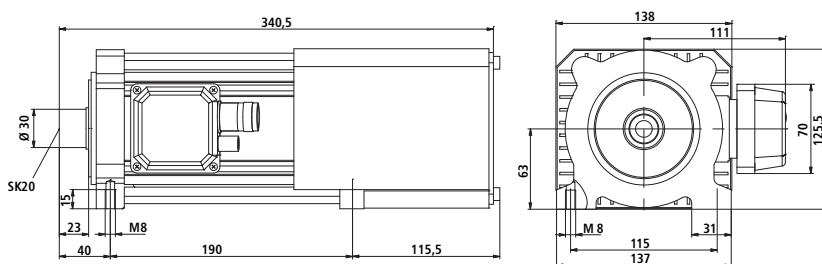

Torque curves

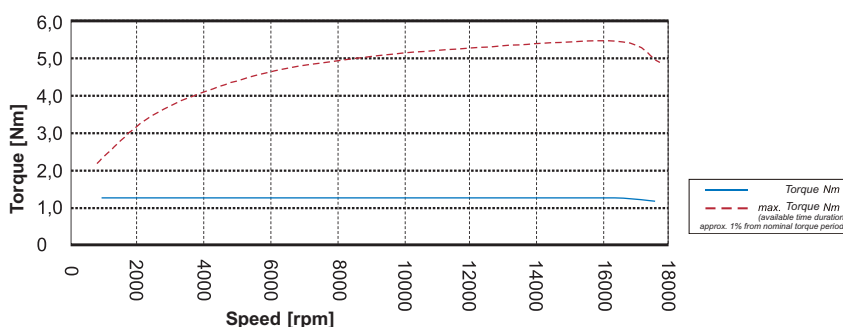

Ordering information

iSA 2200 spindle motor with collets ER 20 (6 mm), nut ERM 20, clamping key ER 20 M, jaw key SW 22, Interconnection connection
Part no.: **477022 3320**

iSA 2200 spindle motor as above, plus frequency converter SKC 1500, motor connecting cable 8 m
Part no.: **310722 3621**

iSA 2200 spindle motor + CoolMin® (internal) with collets ER 20 (6 mm), nut ERM 20, clamping key ER 20 M, jaw key SW 22, Interconnection connection
Part no.: **477022 5320**

iSA 2200 with converter + CoolMin® (internal) as above, plus frequency converter SKC 1500, motor connecting cable 8 m
Part no.: **310722 3631**

SK 20 tool change station 4-fold with hood
Part no.: **239011 0041**

SK 20 tool holder
Part no.: **239172 0020**

Suction device for EuroMod/FlatCom, prepared for hose Ø 80 mm, pneumatic opening
Part no.: **239012 0002**

Suction device with CoolMin® (external) for EuroMod/FlatCom, prepared for hose Ø 80 mm, pneumatic opening
Part no.: **239012 0003**

CoolMin® (external)
Part no.: **239011 0119**

Clamping set ER 20 2.0/3.0/4.0/5.0/6.0/7.0/8.0/9.0/10.0/11.0/12.0/13.0 mm
Part no.: **239172 0001**

Mounting plate isel System (Z axis)
FlatCom / EuroMod Part no.: **277028 0004**
LES 5 Part no.: **277028 0005**

Technical specifications subject to change.

Spindle motor

with **automatic tool changer**

iSA 1500WL



iSA 1500WL

Technical Data

Description		iSA 1500WL
Torque at nominal speed 6,000 rpm	[Nm]	2,5
Max. Speed	[rpm]	1,000 - 20,000
Cut-off frequency	[Hz]	100
Number of poles		2
Rated voltage	[V]	3 x 230 /star connection
Rated current	[A]	6
cos ϕ		0.35
Rated power (S6 = 40% operation)	[W]	1,500
Concentricity	[mm]	0.01
Weight	[kg]	14.0

Features

- Robust 2-pole AC motor (hardened motor shaft)
 - Protection class IP55, Isulation class F
 - Cast bearing apron A and B sides
 - Rated output 1.5 kW (S6-40% operation)
 - Rotational speed range 6,000 rpm / 100 Hz
 - Rated torque 2.5 Nm (at 6,000 rpm)
 - Specific torque rating for drilling and lowering in the speed range 1,000-20,000 rev / min
 - Rated voltage 3 x 230 V
 - Automatic tool change
 - Clamping range \varnothing 2 mm – \varnothing 13 mm
 - Separately driven fan B-side
 - Controlled by frequency converter
 - Double precision bearings
 - SK 20 tool changer pneumatic (7,5 bar)
 - Concentricity: 0.01 mm
 - Weight: 14.0 kg
- **Optional:**
 - CoolMin® Tool and material cooling (external)
 - Frequency converter
 - Tool changer
 - Collets

Dimensioned drawings

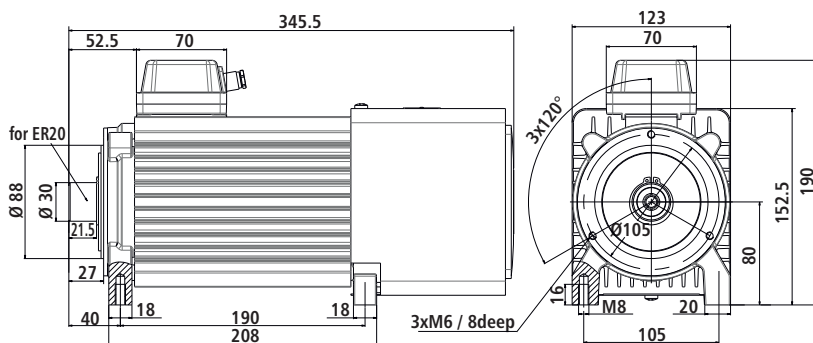

Torque curves

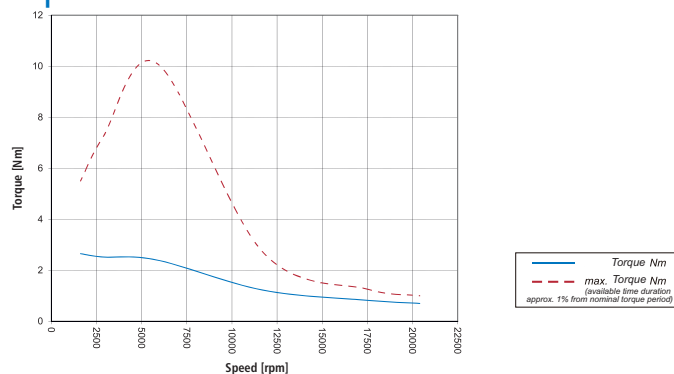

technical specifications subject to change

Ordering information

Spindle motor iSA 1500WL
with collets ER 20 (6 mm), nut ERM 20, clamping key ER 20 M, jaw key SW 22, Interconnection connection
Part no.: **477015 3320**

Spindle motor iSA 1500WL as above, plus
frequency converter SKC 1500, motor connecting cable 8 m
Part no.: **310715 3621**

SK20 tool change station 4-fold with hood
Part no.: **239011 0041**

SK 20 tool holder
Part no.: **239172 0020**

CoolMin® (external)
Part no.: **239011 0119**

Clamping set ER 20
2 / 3 / 4 / 5 / 6 / 7 / 8 / 9 / 10 / 11 / 12 / 13.0 mm
Part no.: **239172 0001**

Mounting plate isel systems (Z-axis)
LES 5 Part no.: **277028 0019**

Spindle motor

with automatic tool changer

iSA 3600



iSA 3600 with automatic tool change

Technical specification

Description		iSA 3600
Torque at rated speed 18,000 rpm	[Nm]	4.5
Speed	[rpm]	6,000 to 18,000
Cut-off frequency	[Hz]	300
Number of poles		2
Rated voltage	[V]	3 x 400
Rated current	[A]	5.4
cos ϕ		0.87
S 6 = 40% rated output	[kW]	3.6
Concentricity	[mm]	0.01
Weight	[kg]	23.0

Features

- Robust 2-pole AC motor
- Square shape, protection class IP54, insulation class F
- Cast bearing apron A-side, aluminium extrusion B-side
- Motor shaft to take ER 32 collets
- Rated output 3.6 kW (S6-40% operation)
- Speed range 6,000 rpm. - 18,000 rpm.
- Automatic tool changer with SK 30 tool holder and ER 32 collet, \varnothing 6 mm
- Clamping range \varnothing 3 mm – \varnothing 20 mm
- Intrinsic ventilation B-side
- Two precision bearings
- Controlled by frequency converter
- **Optional:**
 - CoolMin® (external)
 - Frequency converter
 - Tool changing station
 - Various collets, mounting plates and lead lengths

Ordering information

iSA 3600 spindle motor
Part no.: **477822 3600**

iSA 3600 spindle motor with converter and connecting lead (8 m)
Part no.: **310736 3615**

mounting plates LES 5 / FlatCom XL
Part no.: **277028 0009**

- CoolMin® external with hose see page **E-36**
- 4× SK 30 tool change stations see page **E-38**
- 5× SK 30 tool change stations see page **E-38**
- SK 30 tool holder see page **E-38**
- SKC 4000 frequency converter see page **E-41**
- M23 motor side leads see page **E-41**
- collet set, type ER 32 see page **E-42**

Dimensioned drawings

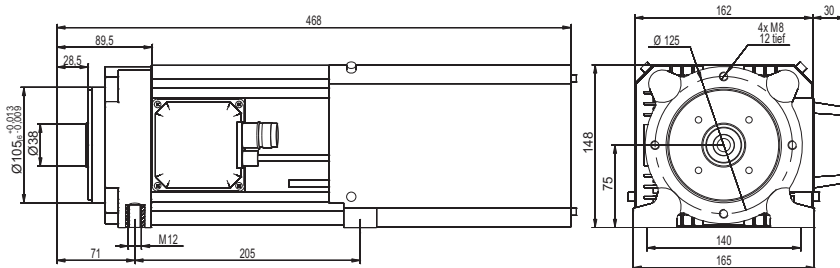

Torque curves

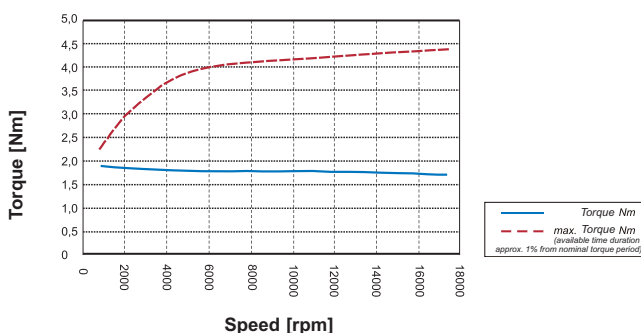

Technical specifications subject to change.

Spindle motor

for high rotational speeds, with **automatic tool changer**

iSA 1500 W



Features

- Precision angular ball bearings
- Automatic tool change with SK 20 tool holder and ER 20 collets, \varnothing 6 mm
- Clamping range \varnothing 2 mm - 13 mm
- Pneumatic tool change (7.5 bar)
- Controlled by frequency converter
- Balancing to EN/ISO standards
- IP54 protection class
- Optional
 - Tool changing station
 - Various collets

Technical specification

Description		
Max. torque	[Nm]	0.47
Max. Speed	[rpm]	40,000 (666 Hz)
Cut-off frequency	[Hz]	500 (30,000 rpm)
Number of poles		2
Rated voltage	[V]	3 x 230
tool holder	[ISO]	20
cos ϕ		0.8
Max. Output power (S 1)	[kW]	1.75
Concentricity	[mm]	under 0.01 or under 0.005 on request
Weight	[kg]	10

Ordering information

iSA 1500 W spindle motor
Part no. **477015 3340**

iSA 1500 W spindle motor with converter
Part no. **310715 3612**

- SKC 1500 frequency converter
see page **E-41**
- collet set, ER20 type
see page **E-42**

Dimensioned drawings

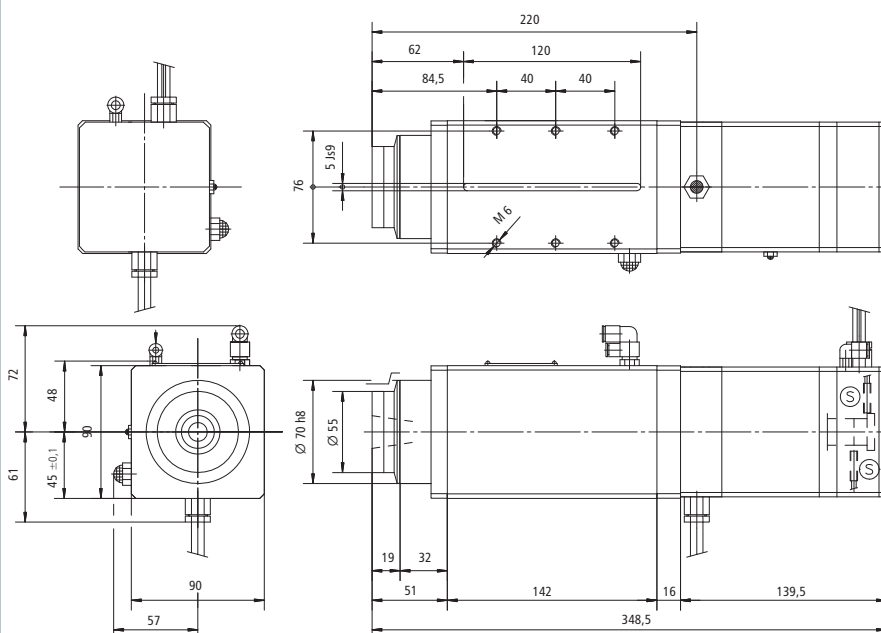

Technical specifications subject to change.

Torque curves

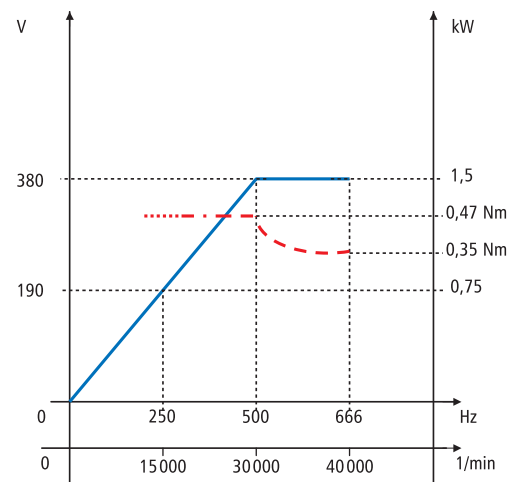

Universal milling and engraving spindles UFM 500/1050



UFM 1050

UFM 500

Technical specification

	Part no.	Load speed rpm	Voltage V	Efficiency %	Power consumption W	Power output W	Torque Nm
UFM 500	420003 0500	22.600	230	68	500	345	0.14
UFM 500-11	420003 0501	22.600	115	68	500	345	0.14
UFM 1050	420003 1050	21000	230	71	1050	720	0.32
UFM 1050-11	420003 1051	21.000	115	71	1050	720	0.32

Dimensioned drawings

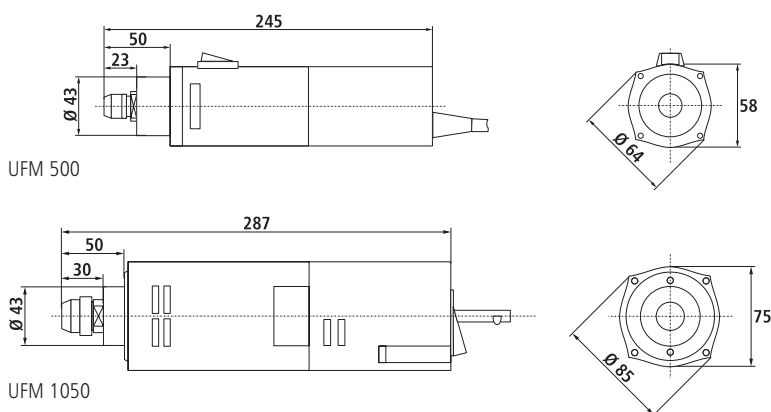

UFM 500

UFM 1050

Features

- Load-independent working speed with Tacho control electronics
- Smooth start for no-backlash acceleration to rated speed
- Blocking protection
- Protective isolation
- PTC thermal monitoring
- Rated output 345 W/720 W
- Speed range 11,000 to 25,000 rpm
- Torque 0.14 Nm (at 22,600/21,000 rpm)
- Rated voltage 230 V
- Collar
- Clamping range
Ø 1 – Ø 6.35 / 8 mm
- Speed control
- Rigid double ball bearing
- Weight: 1.9 / 2.1 kg

UFM 500

- Input power **500 W**
- Output power **345 W**
- Torque **0.14 Nm**

UFM 1050

- Power consumption **1050 W**
- Output power **720 W**
- Torque **0.32 Nm**

Clamping blocks

Clamping blocks Ø 43mm	Part no.
Ra 100 and Ra 150 mm fixings	290 902
Ra 100 mm fixing	290 903
Ra 125 mm fixing	290 904

Collets

collet sets	Part no.
for UFM 500 (Ø 1.0 - 6.35 mm)	239110
for UFM 1050 (Ø 1.0 - 8.0 mm)	239112 0000

Clamping nut

Clamping nut	Part no.
for UFM 500	239 111
for UFM 1050	239 112

Carbon brushes

Carbon brushes, VE = 2 units.	Part no.
for UFM 500	420 003 9000
for UFM 1050	420 003 9001

Technical specifications subject to change.

High frequency spindles

for **manual tool changing** with suitable frequency converters

HFS 800 / 2200



Features Spindles

- Robust 2-pole AC motor
- Speed range
5,000 rpm. – 24,000 rpm.
- Motor shaft to take ER 11 (1-8mm) / ER 20 (1-13mm)
- Spindle bearing, 2 bearings A-side, 1 bearing B-side, SKF bearing
- Round design, protection class IP 54, insulation class F, CE
- Self-ventilation B-side
- M23 connector
- Manual tool change
- Controlled by frequency converter

Options: Clamping block, motor cable, braking resistor, collets

Torque curves

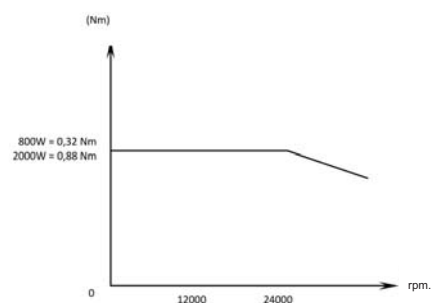

Technical specifications

Description	HFS 800	HFS 2200
Power [W]	800	2200
Torque at rated speed 24,000 rpm. [Nm]	0.32	0.88
Speed [rpm.]	500 to 24,000	
Maximal frequency [Hz]	400	
Cut-off frequency [Hz]	400	
Number of poles	2	
Rated voltage [V]	220	
Rated current [A]	2.5	8.0
cos ϕ	0.9	
Concentricity [mm]	0.01	
Weight [kg]	2.9	5.6

The air cooled high frequency spindle is driven by an diagonal designed squirrel cage motor. This kind of design allows an extremely smooth torque curve.

The HFS spindle series offers a great performance and torque and is used in small and medium-sized systems.

Frequency converter	Item-No.
for HFS 800	310802 2011
for HFS 2200	310802 2012

Features Frequency converter

- Torque control U / F, (vector) open loop
- 100% starting torque at 0.5Hz
- High capacity 150% overload for 60 sec.
- Programmable inputs and outputs, relay output, analog input / output
- 5-digit, removable LED keypad
- Input voltage single phase 230VA
- Fast braking of the spindle by external braking resistor can be connected

Dimensioned drawings

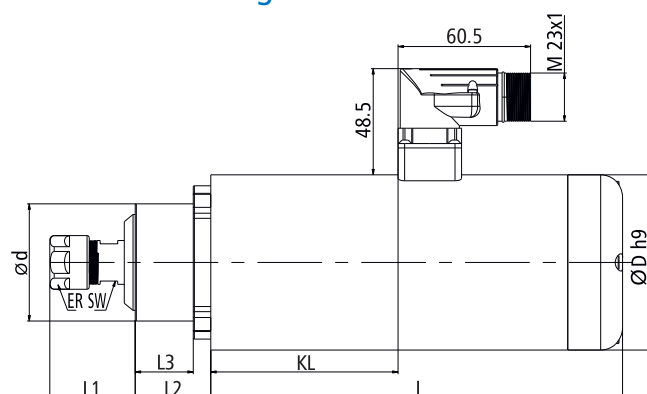

	HFS 800	HFS 2200
Item-No.	477008 30240	477022 30240
ER	11	20
SW	13	22
L [mm]	186.5	244
KL [mm]	103.5	148.5
L1 [mm]	32	46.5
L2 [mm]	16	17
L3 [mm]	8.5	8
d [mm]	49.8	58.5
D [mm]	65	80

Technical specifications subject to change.

Extraction devices in different versions

iAG



Extraction devices iAG 720

Area of application:

- Individual workplace exhaust at machines and manual workstations
- Free-flowing dusts (non-carcinogenic)
- Dry dusts / blades
- Hazardous to health dusts
- High blade / dust generation



Features iAG 720

- Low maintenance costs
- Long life cleanable filter cartridges class M
- Highly mobile unit fitted on movable castors combined with high extraction output
- Tilt-back filter housing for ease of dust disposal
- Suitable for most dust collection applications
- Supplied complete with hose 80mm, L+5m adaptors and mounting clamps

Specific characteristics:

- Manual cleaning
- Cleanable long life cartridge filters
- Special versions supplied with modified filter cartridges to suit application
- Vent connections (optional)
- Special voltage on request
- Floor cleaning kit and machine cleaning kit (optional)



Extraction devices iAG 600

Area of application:

- Individual workstation extraction for industrial and craft applications
- Small mechanical workshops
- Free – flowing dust / wood chips (non-carcinogenic)

Features iAG 600

- Suitable for small work areas
- Ease of use
- Cleanable, long life filter bags
- Low operating costs
- Supplied complete with hose 80mm, L+5m and mounting clamps

Specific characteristics:

- Cleanable filter bags cleaned with crank handle system
- Special versions with filter cartridges air vent and power supply to suit application



Extraction devices iAG 200

Area of application:

- Direct individual workplace extraction
- Free – flowing dust (non-carcinogenic)
- Dry dust and wood chips
- Low dust and wood chip volume

Features iAG 200

- Portable with multi-use applications
- Compact, space-saving design
- Cleanable, long life filter bags dust class M
- Low operating costs
- Supplied complete with hose 50mm, L+5m and mounting clamps

Specific characteristics:

- Integrated compressed air cleaning nozzle

Accessories



Hose, length= 5m
Part-No. 639012 0004
 ... Ø 80 mm, for iAG 720 and iAG 600
Part-No. 639012 0005
 ... Ø 50 mm, for iAG 200



Mounting clamp
Part-No. 639012 0008
 ... up to 170 mm, for iAG 720 and iAG 600
Part-No. 639012 0007
 ... 40-60 mm, for iAG 200



Reduction
 for iAG 720
 (Ø 100 / 80 mm)
Part-No.
639012 0006

Technical specifications subject to change.

Extraction devices

in different versions

iAG

Technical Data

Description		iAG 720	iAG 600	iAG 200
Voltage	[V]	230	400	230
Motor	[kW]	1.3	0.55	1.1
Max. negative pressure	[Pa]	2,800	1,400	19,000
Max. airflow	[m ³ /h]	720	600	200
Sound emission	[dB (A)]	73	68	66
Filter surface	[m ²]	3.5	1	0.8
Number of filter elements		1	1	1
Filter material		„M“-classified	„M“-classified	„M“-classified
Filter cleaning		manual brush cleaning	manual knock off appliance	Compressed air cleaning nozzle
Weight	[kg]	120	30	15
Intake diameter	[mm]	100	80	50
Dust collection bin	[Liter]	appr. 100	appr. 10	appr. 3
Dimensions L x W x H	[mm]	1,165 x 530 x 1,636	400 x 400 x 590	390 x 210 x 500
Part-No.		239012 0030	239012 0032	239012 0031

Dimensioned drawings

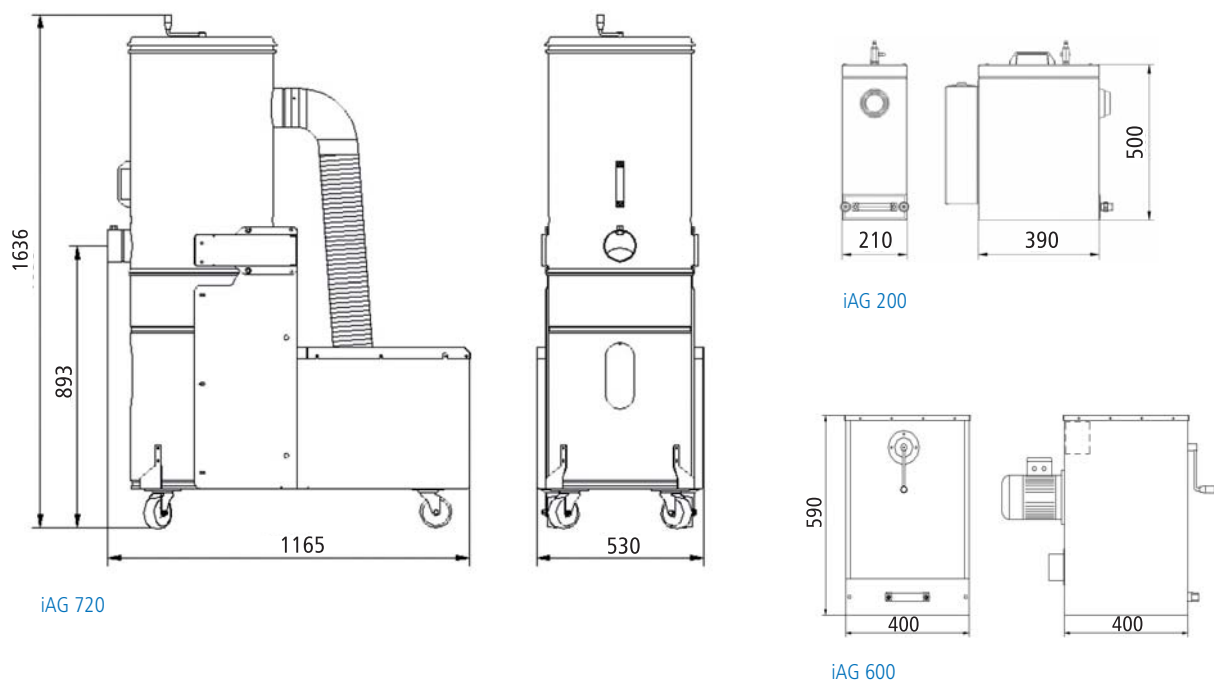

Technical specifications subject to change.

Tool cooling system

COOLMin

Functional principle

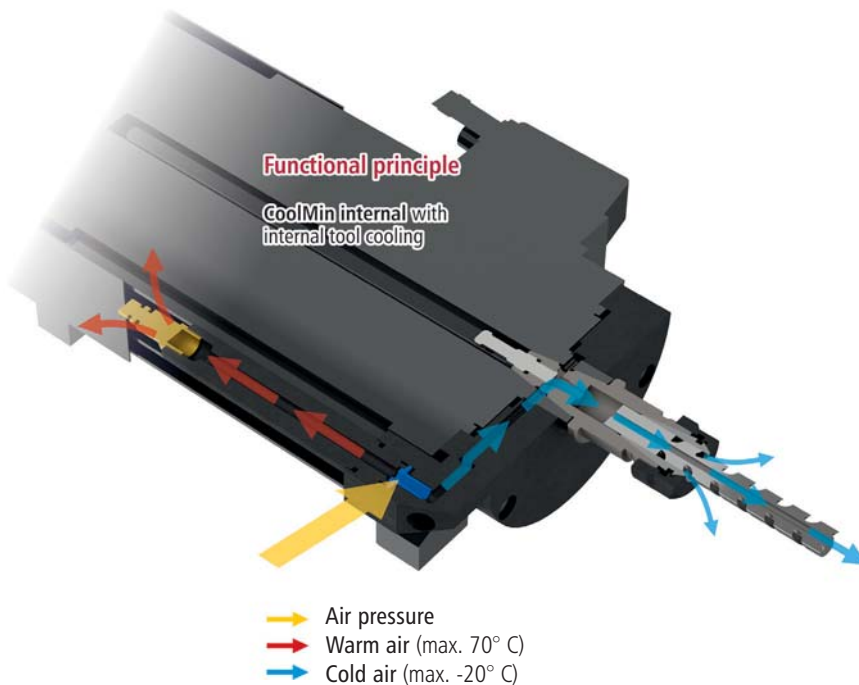

- 1** Spindle motor
- 2** Temperature controller
- 3** Hot air exhaust
- 4** Vortex nozzle with cold air exhaust
- 5** Compressed air feed
- 6** Cold air blower in synthetic material
- 7** Tool holder for internal cooling
- 8** Milling cutter for internal cooling



Tool and material cooling

Dry cutting is today the first choice for many machining tasks.

Hitherto, materials, tool wear and surface finish have often necessitated cooling with appropriate coolants / greases. This always means moisture. Even minimal moisture spray cooling causes unwanted effects such as the build-up of dirt and the adhesion of swarf to the cutting tool or to the working surface and can lead to the deterioration of the material surface structure, depending on the material being machined.

Our patented cooling method ensures adequate tool and surface cooling and reduces such effects to negligible levels. This keeps the swarf dry and, depending on the material, easy to remove by either blowing or vacuuming. Surfaces are therefore protected and, as a result of direct tool cooling, tool life is significantly increased (also suitable for tools with integrated cooling).

The main component of our cooling method is a cold air nozzle, which operates on the eddy current principle and separates warm air from cold.

The system is powered by air pressure alone (6 to 10 bar).

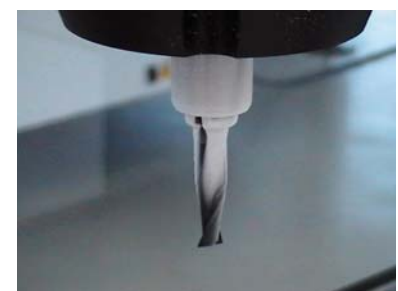

Tool, cooled by CoolMin internal

Technical specifications subject to change.

Tool cooling system

COOLMin

systems

Functional principle

CoolMin external

CoolMin internal without tool cooling system

- ❶ Compressed air feed
- ❷ Flexible mating hose
- ❸ Spindle motor
- ❹ Temperature controller
- ❺ Hot air exhaust
- ❻ Vortex nozzle with Cold air exhaust
- ❼ Cold air supply in synthetic material
- ❽ Collet



Diagram:
CoolMin external
with mating hose



Diagram:
CoolMin internal

Technical specification

Compressed air feed	6 – 10 bar
Cold air exhaust	up to max. -25° C
Hot air exhaust	up to max. 70° C
Air consumption	approx. 150 l/min.

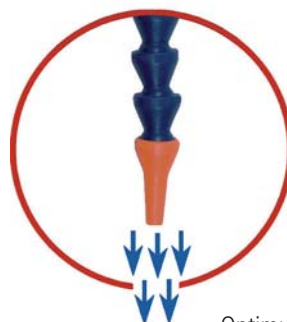

Diagram:
Optimum cold air flow (up to -25°C)
for tool cooling and chip evacuation



Ordering information

Description		Part number
CoolMin external	with mating hose, incl. servicing kit and shut-off tap (manual)	239011 0119
CoolMin external	incl. servicing kit and electrically-powered valve	239011 0117
CoolMin internal		see individual motors

Technical specifications subject to change.

Linear tool change stations

SK 11 / 20 / 30

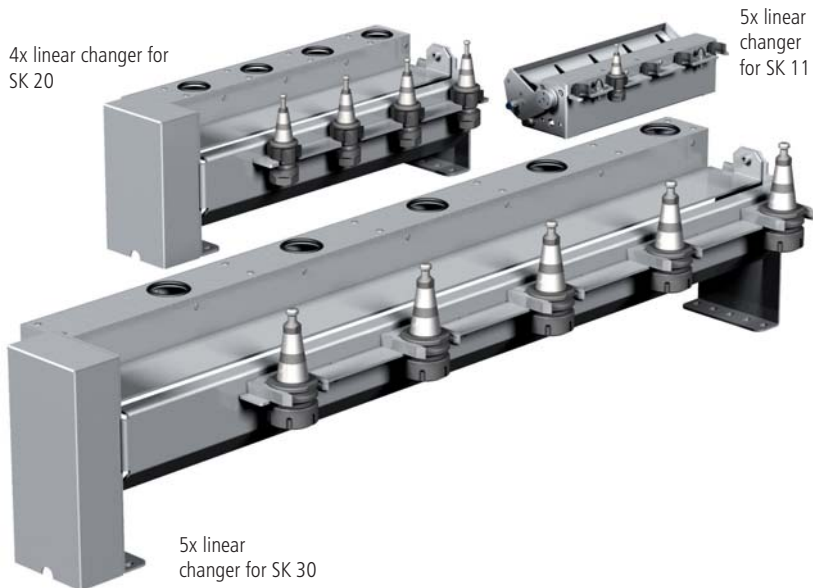

Features

- Simple, functional tool changer for SK 11, SK 20 and SK 30
- Pneumatic rotary cylinder and end position monitoring for safe changing
- Control via 5/2-way valve with integration in the safety circuit
- Low-maintenance, stainless steel design (powder-coated aluminium)
- Variable positioning on the machine bench

Ordering information

SK 11 tool change station ...for iSA 900

5x, with hood + pneumatics
Part-no.: **239011 0053**

8x, with hood + pneumatics
Part-no.: **239011 0083**

SK 20 tool change station ...for iSA 2200

4x (in steps of 100mm),
with hood + pneumatics
Part-no.: **239011 0041**

8x (in steps of 100mm),
with hood + pneumatics
Part-no.: **239011 0081**

5x (in steps of 170mm),
with hood + pneumatics
Part-no.: **239011 0050**

10x (in steps of 170mm),
with hood + pneumatics
Part-no.: **239011 0100**

SK 30 tool change station ...for iSA 3600

4x, with hood + pneumatics
Part-no.: **239011 0045**

5x, with hood + pneumatics
Part-no.: **239011 0055**

Tool holders



SK 11

SK 20

SK 30

SK 11 for collets Type ER 11
Part-no.: **239111 0001**

SK 20 for collets Type ER 20
Part-no.: **239172 0020**

SK 30 for collets Type ER 32
Part-no.: **239130**

Collets see page **E-42**.

Linear tool change stations

SK 11 / 20 / 30

Dimensioned drawings

Tool change stations SK 11

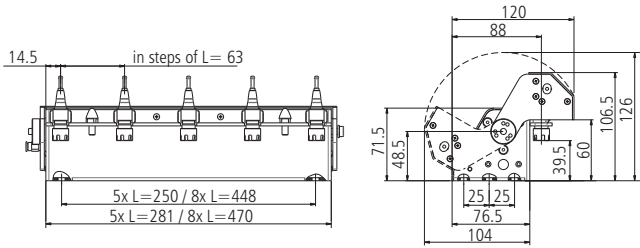

Tool change stations SK 20

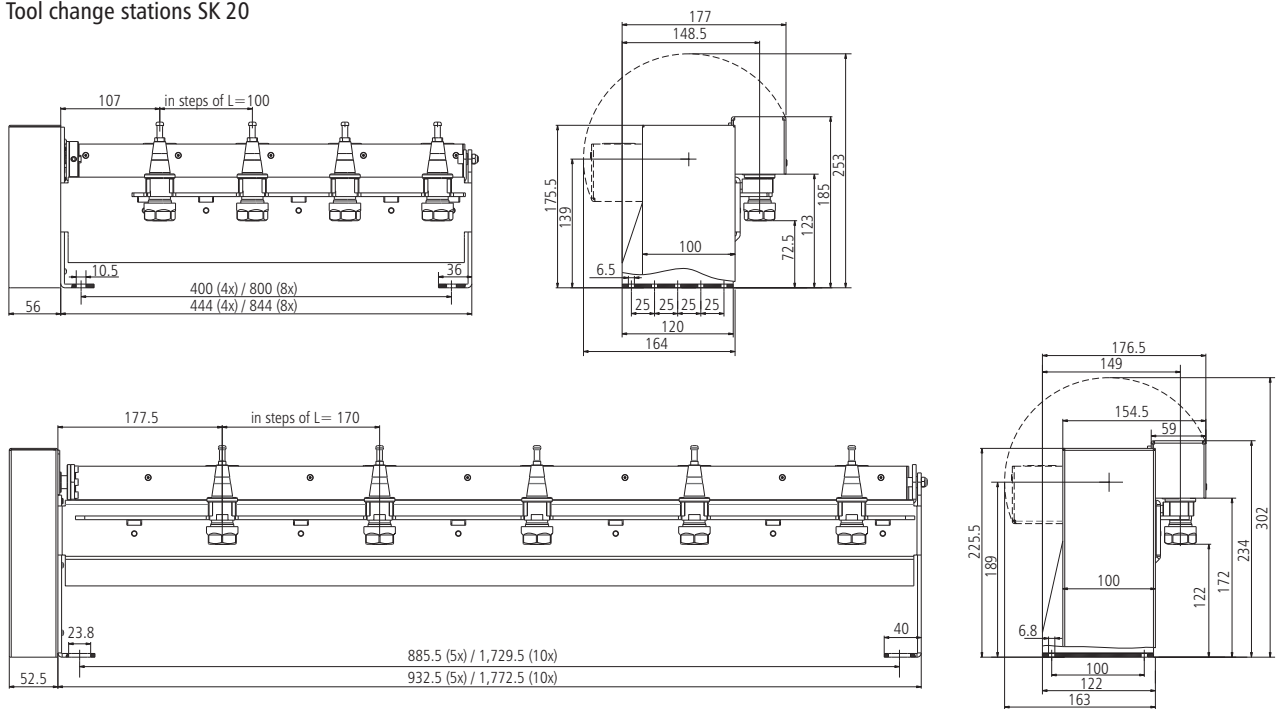

Tool change stations SK 30

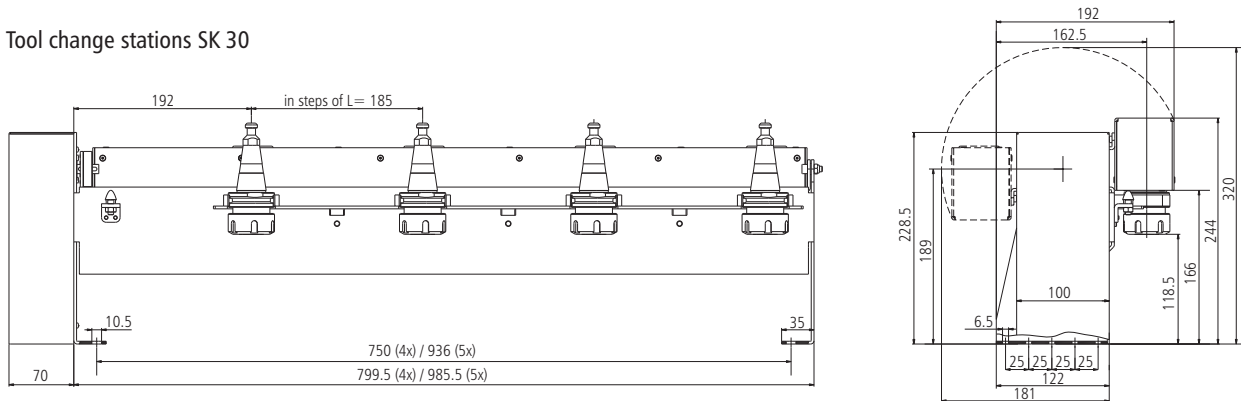

Technical specifications subject to change.

Turned tool change stations

SK 11 / 20

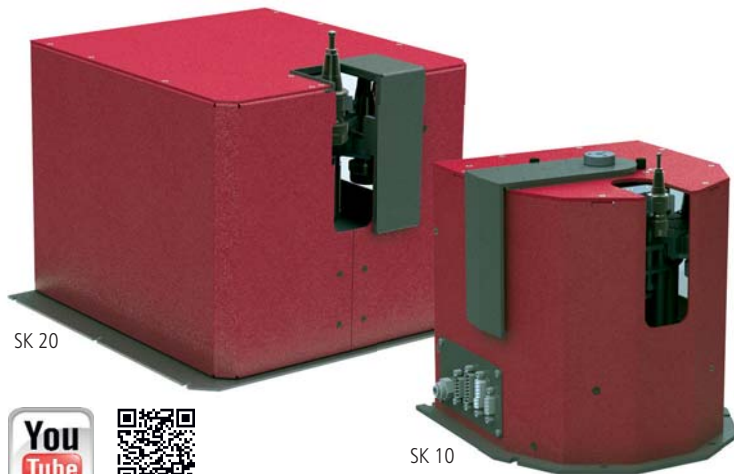

SK 20



SK 10

Interesting application videos can be found on our YouTube channel. Just take a look!

Features

- compact, space-saving design by circular tool positions
- powder-coated aluminium housing (RAL 3011)
- integrated power electronics for controlling via isel CNC commands via RS232 interface
- monitored tool positions and tool opening via sensors
- linear movement of the tool holder and the opening changer via switchable solenoid valves (5/2-way valve)
- used on all common isel Servo CNC machines
- easy to service

Dimensioned drawings

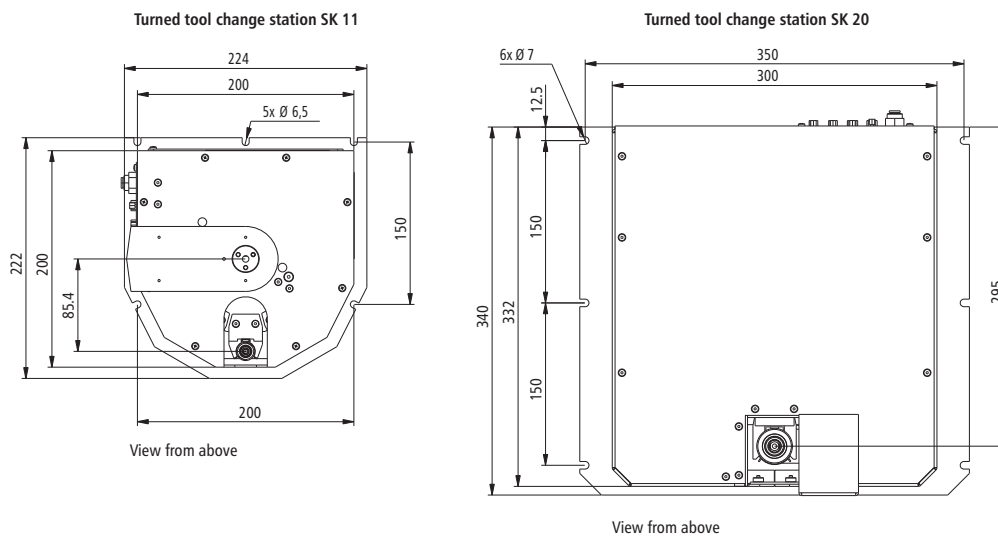

Technical data and ordering information

	turned tool change station SK 11	turned tool change station SK 20
Tool places	12	14
max. tool length [mm]	60	75
min.gap height [mm]	250	350
Suitable spindle motor	ISA 900	ISA 2200
Interface	RS 232	
Supply voltage	+24 VDC	
Dimensions W x D x H [mm]	224 x 222 x 228	360 x 340 x 271
Part-no.	239100 4900	239100 6630

Technical specifications subject to change.

Frequency converter, motor leads and Vacuum cleaning

Frequency converters



SKC 750 frequency converter, suitable for iSA 500, iSA 750 + iSA 900
Part no.: **311707 6000**

SKC 1500 frequency converter, suitable for iSA 1500 + iSA 2200
Part no.: **311715 6000**

SKC 4000 frequency converter, suitable for iSA 3600
Part no.: **311740 6500**

- Compact, pulse width modulated equipment in three output classes
- Input voltage, 230 V AC, single phase (SKC 750/1500) or 400 V AC, three phase (SKC 4000)
- Three phase, vector controlled control voltage frequency 0...1500 Hz
- Fast spindle braking with highly stressed, integrated brake resistance in the sub-frame
- Turn-off EMC filter
- Programmable inputs and outputs, relay output
- User-friendly control unit for configuring spindles
- 95 operating and display parameters for both simple and demanding applications (e. g. spindle energy sink in no load)
- Protection class: IP 20
- Control types: SPS; 0...10 V; 0...20 mA; with operating unit; CAN Bus (additional module required)
- Approved: CE; C-Tick; UL

Length measurement sensor and motor leads



Length measuring sensor for measuring tool lengths
Part no.: **239099 0001**

- 8-wire (3x 0.75 mm² + 1x PE + 2x(2 × 0.34 mm²))
- Drag chain compatible
- External braiding and separately shielded pairs
- Pre-fabricated



Motor side - M23 plug
Converter side - wire end bushings
Part no.: **392306 0300** (3 m)
Part no.: **392306 0500** (5 m)
Part no.: **392306 0800** (8 m)

Motor side - direct connection
Converter side - wire end bushings
Part no.: **392301 0300** (3 m)
Part no.: **392301 0500** (5 m)
Part no.: **392301 0800** (8 m)

Vacuum cleaning

... for iSA 500 + iSA 750 spindles

- prepared for hose 38 mm
- manual opening

Part no.: **239012 0000**

... for iSA 900 spindle

- prepared for hose 50 mm
- automatic opening

Part no.: **239012 0004**

... for iSA 1500 spindle

- prepared for hose 80 mm
- manual opening

Part no.: **239012 0001**

... for iSA 2200 spindle

- prepared for hose 80 mm
- automatic opening

Part no.: **239012 0002**

... for iSA 2200 spindle with external CoolMin

- prepared for hose 80 mm
- automatic opening

Part no.: **239012 0003**

... for iSA 3600 spindle

- prepared for hose 80 mm
- pneumatic opening

Part no.: **239012 0005**

Dust cover closed

Air hose inside diameter 80 mm



Dust cover open

Technical specifications subject to change.

Overview of collets and tool holders

tool holders



SK 11 SK 20 SK 30

SK 11 for collets, type ER 11
Part no.: **239111 0001**

SK 20 for collets, type ER 20
Part no.: **239172 0020**

SK 30 for collets, type ER 32
Part no.: **239130**

Cutting end mills Ultra-N



- for non-ferrous materials, with exemption
- with a defined cutting edge rounding
- Tool material Solid Carbide Micro Grain uncoated with mirror finished
- Large chip space for unobstructed chip flow

Milling box small // 6-piece (1,5 / 2 / 3 / 4 / 5 / 6 mm) Item-No.: **239200 0003**

Milling box big // 6-piece (3 / 4 / 6 / 8 / 10 / 12 mm) Item-No.: **239200 0004**

The following collets are also able to clamp shafts reduced in diameter by 0.5 mm:

Collets type ER 11

for iSA 500 and iSA 900

Ø (mm)	Part no.
1.0	239170 1000
1.5	239170 1500
2.0	239170 2000
2.5	239170 2500
3.0	239170 3000
3.5	239170 3500
4.0	239170 4000
4.5	239170 4500
5.0	239170 5000
5.5	239170 5500
6.0	239170 6000
6.5	239170 6500
7.0	239170 7000

Collet set

for spindle motor	Type	Ø (mm)	Part no.
iSA 500/iSA 900	ER 11	1.0 - 7.0	239170 0001

Clamping nuts

Type	Part no.
ERM 11	239170
ERM 16	239171
ERM 20	239172



ER 11



ER 16



ER 20

The following collets are also able to clamp shafts reduced in diameter by 1.0 mm:

Collets type ER 16

for iSA 750

Ø (mm)	Part no.
1.0	239171 1000
2.0	239171 2000
3.0	239171 3000
4.0	239171 4000
5.0	239171 5000
6.0	239171 6000
7.0	239171 7000
8.0	239171 8000
9.0	239171 9000
10.0	239171 0100

Collets type ER 20

for iSA 1500 and iSA 2200

Ø (mm)	Part no.
2.0	239172 2000
3.0	239172 3000
4.0	239172 4000
5.0	239172 5000
6.0	239172 6000
7.0	239172 7000
8.0	239172 8000
10.0	239172 0100
11.0	239172 0110
12.0	239172 0120
13.0	239172 0130

Collets type ER 32

for iSA 3600

Ø (mm)	Part no.
3.0	239130 3000
4.0	239130 4000
5.0	239130 5000
6.0	239130 6000
7.0	239130 7000
8.0	239130 8000
9.0	239130 9000
10.0	239130 0100
11.0	239130 0110
12.0	239130 0120
13.0	239130 0130
14.0	239130 0140
15.0	239130 0150
16.0	239130 0160
17.0	239130 0170
18.0	239130 0180
19.0	239130 0190
20.0	239130 0200

Collet sets

for spindle motor	Type	Ø (mm)	Part no.
iSA 750	ER 16	1.0 - 10	239171 0001
iSA 1500 / iSA 2200	ER 20	2.0 - 13	239172 0001
iSA 3600	ER 32	3.0 - 20	239130 0000

Vacuum clamping plates

VAKUFIT®

Sample diagram



Multiple connections for high volume flow and optimal vacuum distribution.



All our vacuum plates can be arranged to fit together to cover large areas.

Part number	Description	DIN	Clamping surface
216601 0017	VT 2115	A5	210 x 150 mm
216601 0018	VT 3021	A4	300 x 210 mm
216601 0019	VT 4230	A3	420 x 300 mm
216601 0020	VT 6042	A2	600 x 420 mm
216601 0030	Rotary vane pump (10.0 m ³ /h) for DIN A4 und A5		
216600 0028	Servicing kit for rotary vane pump 10.0 m ³ /h		
216601 0010	Connection set vacuum plate to rotary vane pump		
616601 2115	Rubber matting for vacuum plates A5		
616601 3021	Rubber matting for vacuum plates A4, T=1 mm		
616601 3022	Rubber matting for vacuum plates A4, T=3 mm		
616601 3023	Rubber matting for vacuum plates 1200 x 900 mm		

Technical specifications subject to change.

VakuFit - L

The raster plates for the vacuum clamping makes little demand on the vacuum pump. The plates are almost totally warp free and the material is therefore suitable for engraving operations when clamped.

In contrast to other vacuum clamping methods, surfaces can be milled over large areas without problem, with parts remaining securely clamped.

Material stops can be easily effected by inserting 5 mm dowelling pins into the raster plate holes. The board rubber matting is a consumable with a variety of uses. In addition to our standard plates, we offer customised variants and complete plate packages for special applications.

Note

Retaining force is proportional to the area covered, the coefficient of friction and the differential pressure.

In order to increase the coefficient of friction, rubber matting is included within the scope of delivery.

Scope of delivery

- 1x connection adapter
- 1x screw key 68 mm
- 1x rubber matting for holes
- 1x rubber matting for covering unused holes
- Operating instructions

Introduction



As a division within isel Germany AG, isel Robotik presents a cross-section of its product portfolio of automation components for robots, wafer-handler, prealigners, linear units, end effectors and accessories for the semiconductor industry, made in Germany. The company's Robotics Division has been operating for more than 10 years within the semiconductor sector. Sales began in 2004 with just a few types of robot and prealigner. Today the range of components for the semiconductor industry covers the needs of all OEM customer within the semiconductor sector. Since 2004, over 1000 robot systems have been successfully put into service. For these processes, in addition to clean room compatibility, high precision and reliability are paramount. Since these requirements affect the entire production process in the chip industry, stringent specifications also apply with regard to component handling. Handling components exemplify isel Germany's market reputation: very high quality, short delivery times, the best possible service and a very good price-performance ratio. Ask for an appointment with one of our applications engineers. We look forward to your visit and an opportunity to serve your automation, robotic and handling needs.

We're there for you...

...because you'll get it all from one source

Because we control all aspects of our products life cycle, from design, production, sales and service, we ensure you will receive competent contacts for all questions concerning our products.

...with more than 40 years of market presence

Supporting iselRobotik department is the renowned and internationally-active isel Germany AG. Benefit from our market presence of many years in a variety of industry lines.

...in the heart of Europe

Our location in Eichenzell (Hesse) in central Germany is close to Europe's semiconductor key locations.

Visit us under www.iselrobotik.com

Overview

Series 1 robots are designed for wafer handling. The modular system allows the combination of various base bodies, from 7" to 21" Z stroke, with a large number of different arm modules from 10.5" to 28". Handling weights of up to 3 kg are also possible with the appropriate combination of axes.

<p>■ Wafer Handling Robots IWH Series 1 with 2-link compact arm and 7 inch body series 1</p>	<p>E-46</p>
<p>■ Wafer Handling Robots IWH Series 1 with 2-Link-Heavy-Duty arm and standard body</p>	<p>E-47</p>
<p>■ Wafer Handling Robots IWH Series 1 with 3-Link-Heavy-Duty arm and standard body</p>	<p>E-48</p>

Series 3 single-arm robots are used wherever a higher structural rigidity is required. They can be used with loads of up to 3 kg, even in combination with long arm modules and a large Z stroke of up to 21".

<p>■ Wafer Handling Robots IWH Series 3 with 2-Link HDplus arm and body series 3</p>	<p>E-49</p>
-------------------------------------------------------------------------------------------------	-------------

Series 3 dual-arm robots have the potential to increase the throughput of an application. The two independent arms mean that the wafers on a station can be replaced very quickly and thus empty runs are prevented.

<p>■ Wafer Handling Robots IWH Series 3 with 2-Link dual arm and body series 3</p>	<p>E-50</p>
<p>■ Wafer Handling Robots IWH Series SHD with SHD dual arm and series SHD body</p>	<p>E-51</p>

<p>■ Controller & Software „Standard“</p>	<p>E-52</p>
------------------------------------------------------	-------------

<p>■ Controller & Software „Advanced“</p>	<p>E-53</p>
------------------------------------------------------	-------------

<p>■ Linear Track</p>	<p>E-54</p>
------------------------------	-------------

<p>■ End effectors</p>	<p>E-55</p>
-------------------------------	-------------

<p>■ Prealigner</p>	<p>E-56</p>
----------------------------	-------------

<p>■ Accessories</p>	<p>E-58</p>
-----------------------------	-------------

<p>■ References</p>	<p>E-59</p>
----------------------------	-------------

Wafer Handling Robots

with 2-link compact arm and 7 inch body series 1

IWH Series 1



Figure:
IWH-TA07S10F-1

Features

- Cost-effective
- Excellent structural rigidity and precision
- Maximum reliability
- Top mounted (TA) or bottom mounted (BA) versions available
- Customized designs
- Incremental encoder
- Seamless integration with prealigner, linear track and other peripheral components
- Including „Standard“ Controller & Software
- ISO 1 clean-room environment compatible
- MTBF: > 50,000 operating hours
- Made in Germany

Technical specifications

Description	IWH F-1	
Repeat accuracy	T	±0.02°
	R	±0.02 mm
	Z	±0.02 mm
Working area	Z	7"
	radial	10", 14"
	theta	450°
Payload	up to 1kg	
Maximum speed	T	360°/s
	R	1,000 mm/s
	Z	450 mm/s
Power supply	110 / 230 V AC	
Interface	RS-232 [DB9], Ethernet [RJ-45]	

Dimensioned drawings

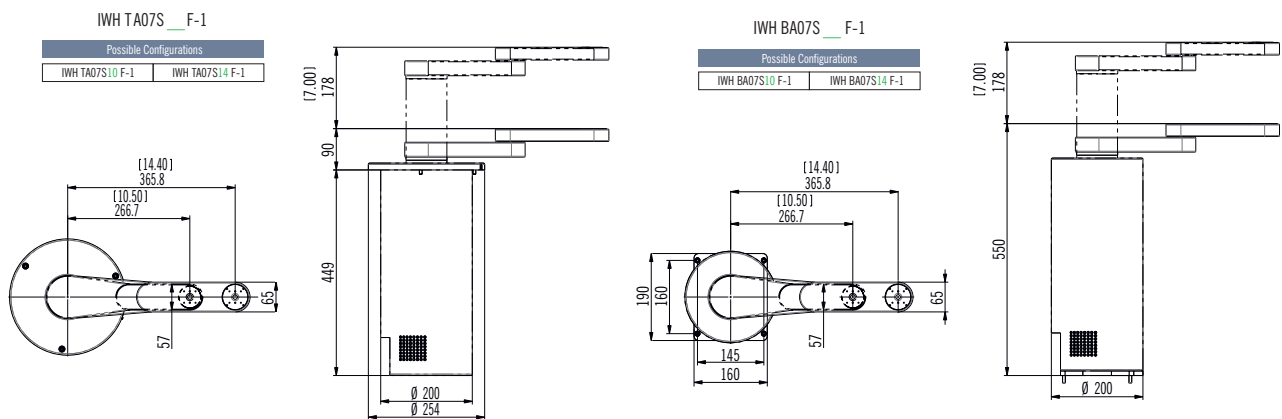

Wafer Handling Robots

with 2-Link-Heavy-Duty arm and standard body

IWH Series 1



Figure:
IWH TA10S10HD F-1

Features

- Excellent structural rigidity and precision
- Maximum reliability
- Top mounted (TA) or bottom mounted (BA) versions available
- Customized designs
- Absolute (digital) or incremental encoder
- Seamless integration with prealigner, linear track and other peripheral to the control
- including "Standard" or "Advanced" Hard- & Software
- ISO 14664-1 class 1 clean-room environment
- MTBF: > 50,000 operating hours
- Made in Germany

Technical specifications

Description	IWH F-1	
Repeat accuracy	T	±0.02°
	R	±0.02 mm
	Z	±0.02 mm
Working area	Z	10", 13", 17", 21"
	radial	10", 12", 14", 16", 20"
	theta	500°
Payload	up to 3 kg, optional: kompakt arm up to 1kg for 10" and 14"	
Maximum speed	T	360°/s
	R	1.000 mm/s
	Z	450 mm/s
Power supply	110 / 230 V AC	
Interface	RS-232 [DB9], Ethernet [RJ-45]	

Dimensioned drawings

IWH TA_S_HD F-1

Possible Configuration	
IWH TA10S10HD F-1	IWH TA17S10HD F-1
IWH TA10S12HD F-1	IWH TA17S12HD F-1
IWH TA10S14HD F-1	IWH TA17S14HD F-1
IWH TA10S16HD F-1	IWH TA17S16HD F-1
IWH TA10S20HD F-1	IWH TA17S20HD F-1
IWH TA13S10HD F-1	IWH TA21S10HD F-1
IWH TA13S12HD F-1	IWH TA21S12HD F-1
IWH TA13S14HD F-1	IWH TA21S14HD F-1
IWH TA13S16HD F-1	IWH TA21S16HD F-1
IWH TA13S20HD F-1	IWH TA21S20HD F-1

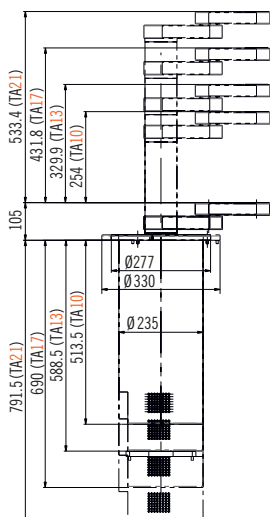
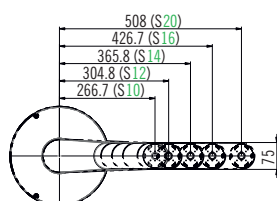

IWH BA_S_HD F-1

Possible Configuration	
IWH BA10S10HD F-1	IWH BA17S10HD F-1
IWH BA10S12HD F-1	IWH BA17S12HD F-1
IWH BA10S14HD F-1	IWH BA17S14HD F-1
IWH BA10S16HD F-1	IWH BA17S16HD F-1
IWH BA10S20HD F-1	IWH BA17S20HD F-1
IWH BA13S10HD F-1	IWH BA21S10HD F-1
IWH BA13S12HD F-1	IWH BA21S12HD F-1
IWH BA13S14HD F-1	IWH BA21S14HD F-1
IWH BA13S16HD F-1	IWH BA21S16HD F-1
IWH BA13S20HD F-1	IWH BA21S20HD F-1

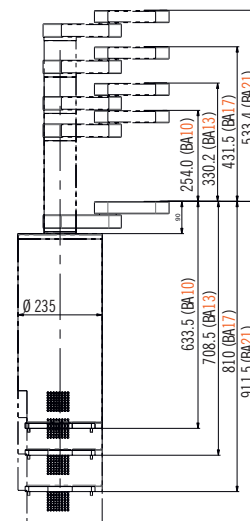
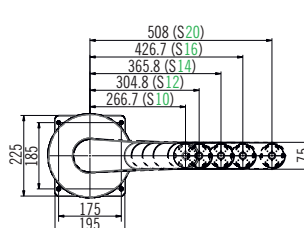

Wafer Handling Robots

with 3-Link-Heavy-Duty arm and standard body

IWH Series 1



Figure:
IWH TA10S16 F-1

Features

- Excellent structural rigidity and precision
- Maximum reliability
- Top mounted (TA) or bottom mounted (BA) versions available
- Customized designs
- Absolute (digital) or incremental encoder
- Seamless integration with prealigner, linear track and other peripheral to the control
- including "Standard" or "Advanced" Hard- & Software
- ISO 14664-1 class 1 clean-room environment
- MTBF: > 50,000 operating hours
- Made in Germany

Technical specifications

Description	IWH F-1	
Repeatability	T	±0.02°
	R	±0.02 mm
	Z	±0.02 mm
Working area	Z	10", 13", 17",
	radial	16", 21", 24", 28"
	theta	500°
Payload	up to 3 kg	
Maximum speed	T	360°/s
	R	1.000 mm/s
	Z	450 mm/s
Power supply	110 / 230 V AC	
Interface	RS-232 [DB9], Ethernet [RJ-45]	

Dimensioned drawings

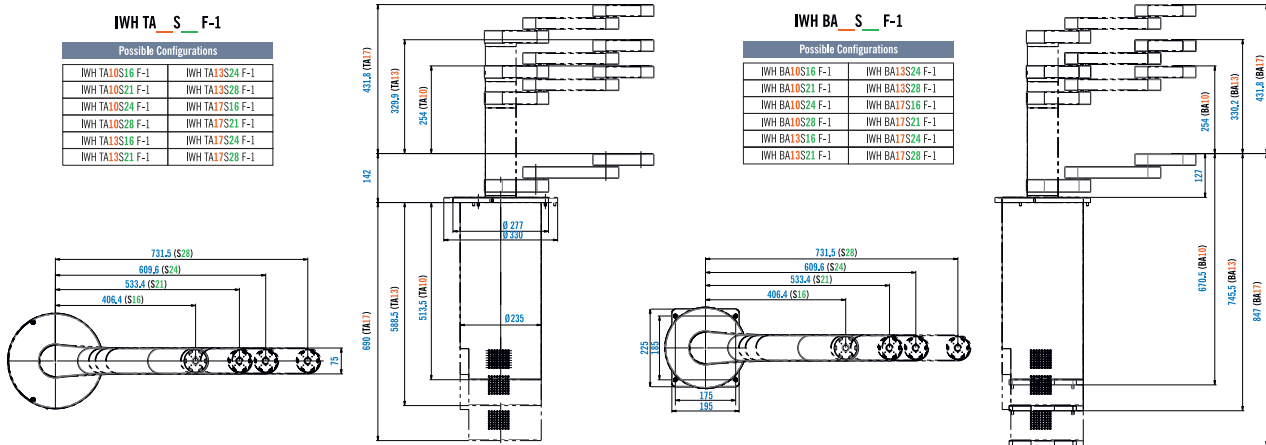

Wafer Handling Robots

with 2-Link HDplus arm and body series 3

IWH Series 3



Figure:
IWH TA13S24HDP F3

Features

- Excellent structural rigidity and precision
- Maximum reliability
- Top mounted (TA) or bottom mounted (BA) versions available
- Customized designs
- Absolute (digital) or incremental encoder
- Seamless integration with prealigner, linear track and other peripheral to the control
- including "Standard" or "Advanced" Hard- & Software
- ISO 14664-1 class 1 clean-room environment
- MTBF: > 50,000 operating hours
- Made in Germany

Technical specifications

Description	IWH F-3	
Repeatability	T	±0.02°
	R	±0.02 mm
	Z	±0.02 mm
Working area	Z	7", 10", 13", 15", 17", 21"
	radial	16", 24"
	theta	450°
Payload	up to 5 kg	
Maximum speed	T	360°/s
	R	1.000 mm/s
	Z	425 mm/s
Power supply	110 / 230 V AC	
Interface	RS-232 [DB9], Ethernet [RJ-45]	

Dimensioned drawings

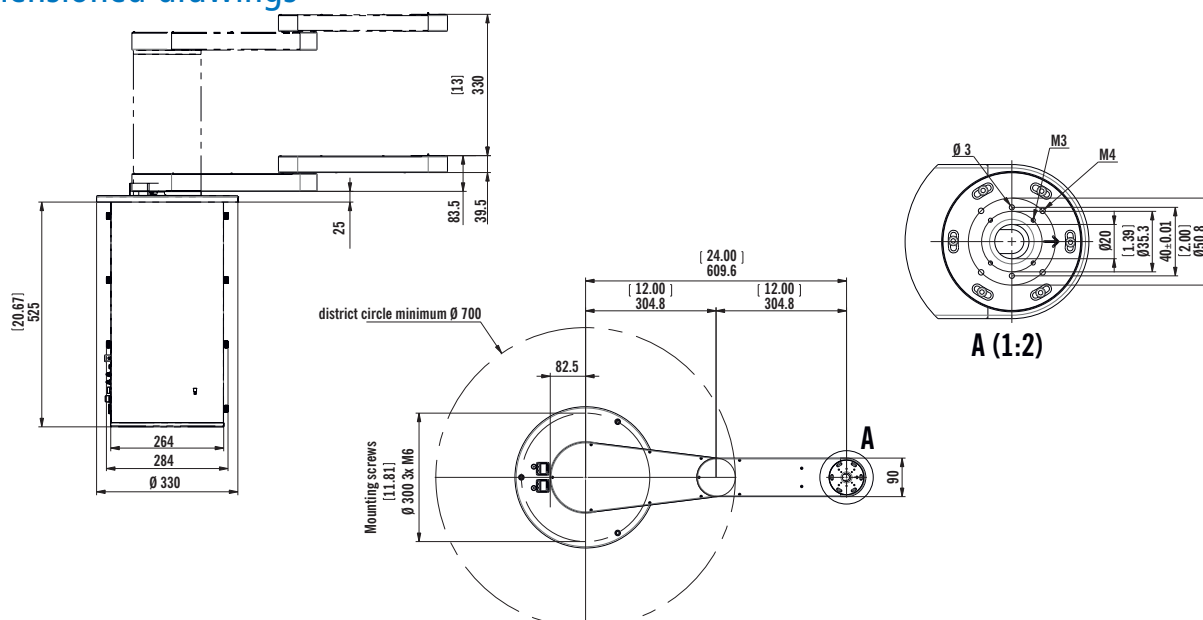

Wafer Handling Robots

with 2-Link dual arm and body series 3

IWH Series 3



Figure:
IWH F-3 Dual arm robot
with vacuum display

Features

- Excellent structural rigidity
- Wafer handling of up to 300mm
- Maximum reliability and precision
- Easy connection of a linear track to the robot controller
- Very smooth running
- Backlash free Harmonic Drive® gears
- Absolute, incremental encoder or resolver
- Integrated 2-channel vacuum display
- Including „Standard“ or „Advanced“ Controller & Software
- ISO 1 clean-room environment compatible
- MTBF: > 50,000 operating hours
- Made in Germany

Technical specifications

Description	IWH F-3	
Repeatability	T	± 0.02°
	R	± 0.02 mm
	Z	± 0.02 mm
Working area	Z	7", 10", 13", 15", 17"
	radial	10", 14"
	theta	500°
Payload	max. 1.25 kg per arm	
Maximum speed	T	360°/s
	R	1.100 mm/s
	Z	425 mm/s
Power supply	110 / 230 V AC	
Interface	RS-232 [DB9], Ethernet [RJ-45]	

Dimensioned drawings

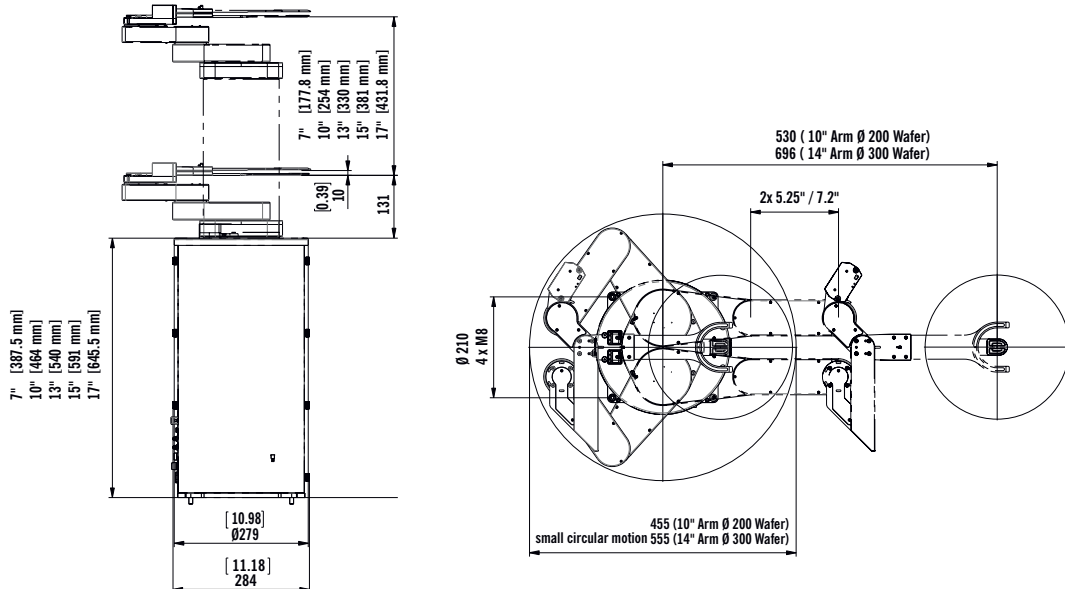

Wafer Handling Robots

with SHD dual arm and series SHD body

IWH Series SHD



Figure:
IWH F-3 SHD Dual arm robot
with vacuum display

Features

- Excellent structural rigidity
- Wafer handling of up to 450mm
- Maximum reliability and precision
- Easy connection of a linear track to the robot controller
- Very smooth running
- Backlash free Harmonic Drive® gears
- Absolute encoder
- Integrated 2-channel vacuum display
- Including „Advanced“ Controller & Software
- ISO 1 clean-room environment compatible
- MTBF: > 50,000 operating hours
- Made in Germany

Option: 2 Flip modules iFM-300-3

Technical specifications

Description	IWH SHD	
Repeatability	T	± 0.02°
	R	± 0.02 mm
	Z	± 0.02 mm
Working area	Z	13", 15"
	radial	14"
	theta	450°
Payload	max. 3 kg per arm	
Maximum speed	T	250°/s
	R	800 mm/s
	Z	300 mm/s
Power supply	110 / 230 V AC	
Interface	RS-232 [DB9], Ethernet [RJ-45]	

Dimensioned drawings

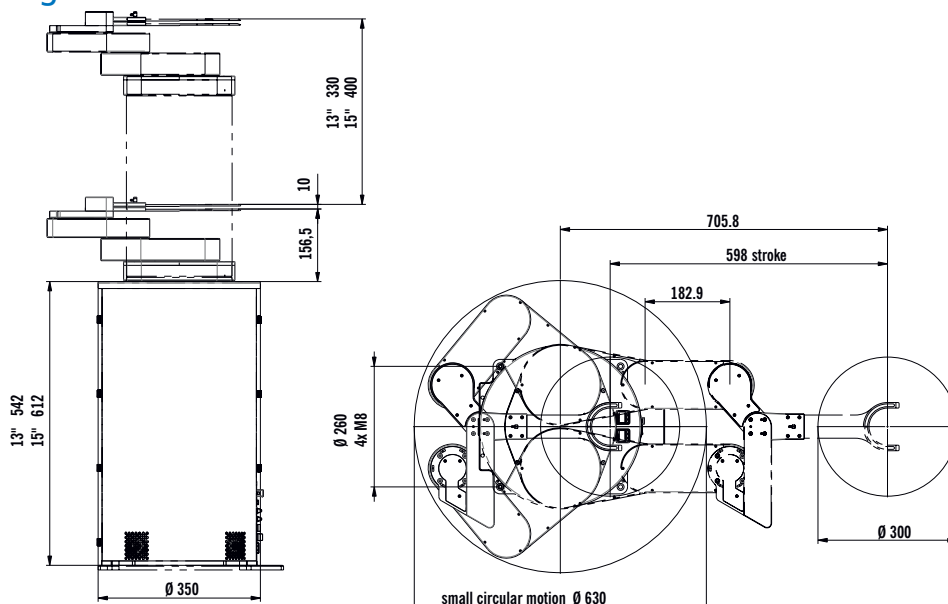

Controller & Software

„Standard“



Figure: Hand terminal IHT for Standard Controller

Figure: isel Standard Robot Controller

General

The controller which is completely integrated into the wafer handler has been in widespread use for over 10 years and has proven itself in the semiconductor industry. As a separate external controller is not used, the handling system only requires very little space and is also well suited for replacing other robot systems (emulations are available on request). The "Standard" hardware & software provides a huge range of pre-installed macro programmes and the option of working with a single-axis prealigner. Provision has been made for the connection of the IHT hand-held terminal for service work.

The Windows-based RCC software provides support for setting up and management of the robot system and its extensive functions.

Features

- optional: Single Axis Prealigner
- Less wiring
- Large range of functions
- OTF-Function
- Integrated electronic (All-in-one-Design)
- approved over 10 years
- Optional Hand control
- Interface: RS232, TelNet

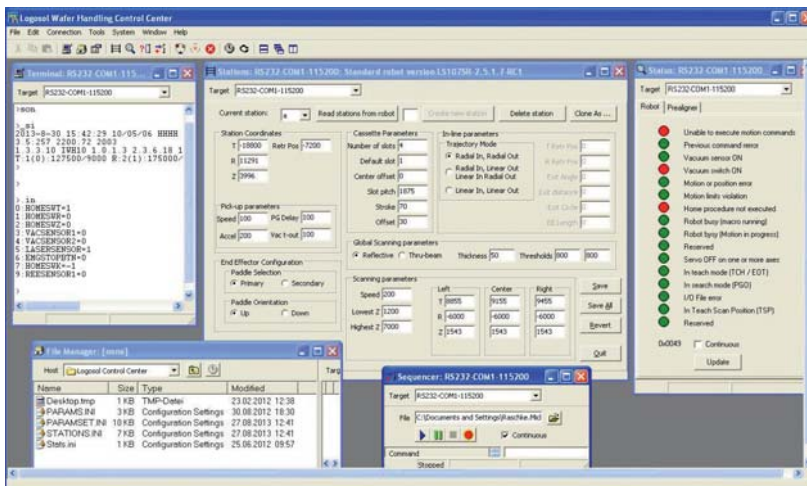

Figure: RCC Software



Figure: All-in-one-Design

Controller & Software

„Advanced“



Figure: Advanced-Controller front



Figure: Advanced-Controller back



Figure: Teach Pendant for Advanced-Controller

General

The Advanced controller is based on a contouring control system with integrated safety PLC which incorporates state-of-the-art technology. The contouring mode makes it possible to set a constant and maximum speed on the TCP, which ensures additional safety when handling the substrate. The controller runs internally with the Powerlink real-time bus system which improves performance even further. The high-voltage technology, with the use of an additional linear motor axis, makes for very dynamic performance. The controller complies with the current international standards for industrial robots. Provision has been made for connection of the ergonomic Teach Pendant with its graphic operating interface, the required functions for safe set-up mode and manual mode.

The operating interface integrated into the controller can be visualised on any PC with a VNC viewer and provides an innovative and intuitive GUI for setting up and managing all functions and a diagnosis and optimisation tool. What is special about the "Advanced" hardware & software is that it is isel's own development and thus further development and know how are exclusive to isel.

Features

- innovative user interface
- support high-voltage technology "State of the Art"
- Integrated safety to DIN EN ISO 10218-1:2008
- Resolver or EnDat-2.2 Giver possible
- as 19" rack or table housing available
- Interface: Ethernet, RS232, IMA
- Dimensions: W 39 x H 16 x D 41.5 mm

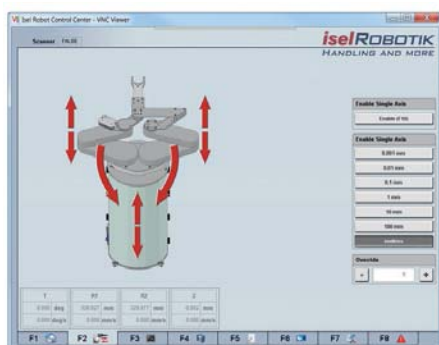

Figure: isel Robot Center



Linear Track

iLD Series



Figure:
iLD 50-6 as Linear Track
for wafer handling robots

Technical specifications

Description	
Repeatability	< 0.01 mm
Drive	Linear motor; optional: spindle
Maximum speed	4.5 m/s
Maximum length	48 m
Maximum acceleration	10 m/s ²
Power supply	110 / 230 V AC

Accessories: assemble set for aligning the axes

Item-No.: **650200 8344**

consisting of 2 adapter plates, 4 nuts, 2 adjusting bolts and mounting material

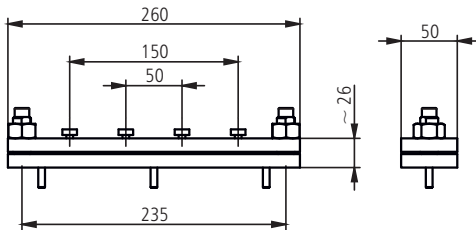

General

The iLD linear track series can be integrated seamlessly into your system's handling area owing to its flexibility. Tracks are controlled in conjunction with our IWJH series robots. This combination of linear tracks with isel robots makes for a very effective system and thus provides high throughputs. Depending on the application, installation can be below or to the side of the robot. The use of brushless servo motors makes linear tracks very responsive dynamically, low maintenance and quiet in operation.

Features

- Maximum speed up to 4.5 m/s
- Maximum acceleration up to 10 m/s²
- Overall lengths up to 15m
- Configurable lateral or bottom mounting
- Excellent structural rigidity
- Robust-industry-proven reliability and precision
- Simple to connection to the robot controller
- Driven by Linear motor
- Free from wear
- Multiple motor operation
- Low-maintenance
- Made in Germany

Dimensioned drawings

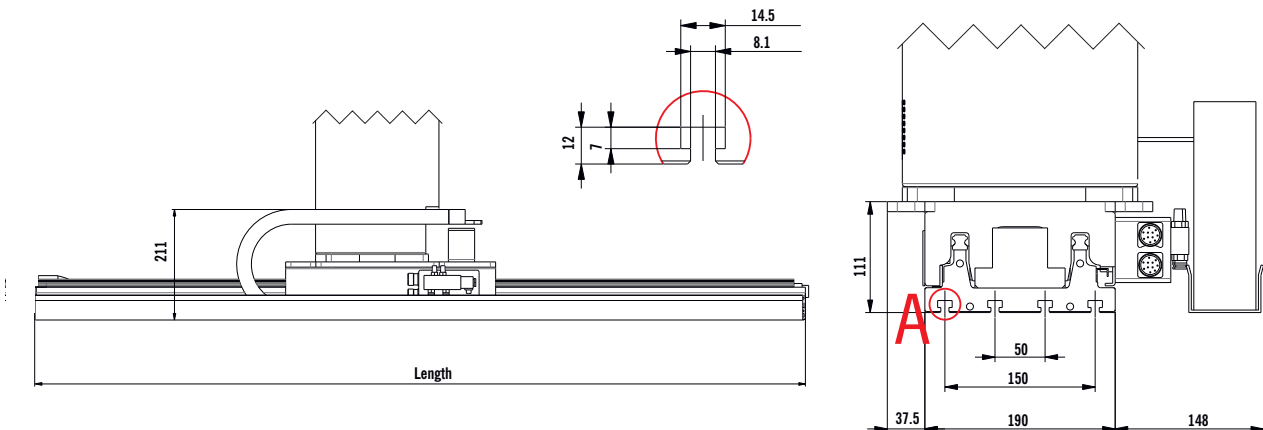

End effectors

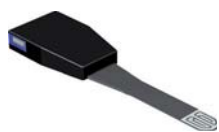

Paddle-EE with scanner



Horse Shoe-EE without scanner



Doppel-EE with Thru Beam-Scanner



Exclusion Zone Vacuum with scanner



Edge Grip with scanner



Customized



Edge Grip EE



Exclusion Zone



Vacuumcontrol



Extended version

Features

- For wafer, masks & filmrings up to 12" (300 mm)
- Modular concept
- Low own weight
- Excellent structural rigidity
- Good cost/ performance ratio
- PTFE coated

Options

- diverse wafer mapping sensor
- several surface coatings
- Special designs
 - Pocket EE
 - Friction Wafer
 - Edge Grip EE
 - Exclusion zone Grip EE
 - Exclusion zone Vacuum EE
 - Multiple EE

Accessories

Vacuum control

- Extremely fast response
- Freely programmable
- Resolution of 0.001 bar
- Built-in end effector
- Bicoloured display
- Useable for all vacuum end effectors

Ordering key

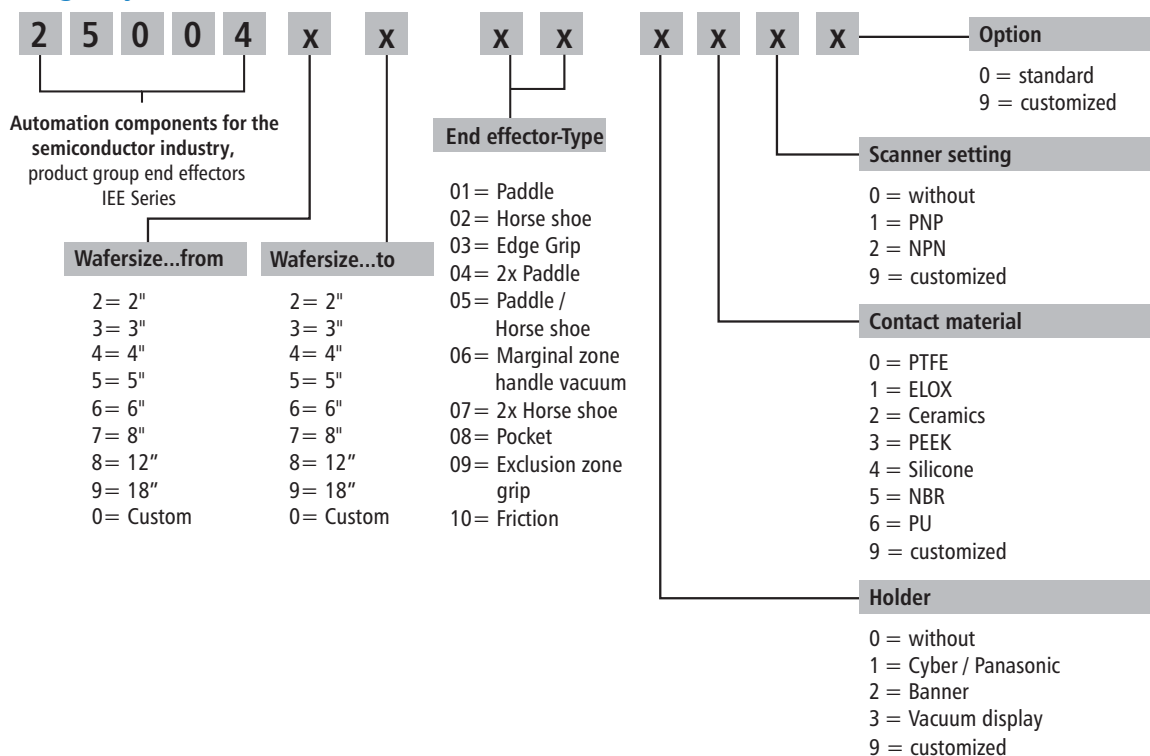

Prealigner



Three-axis prealigner
LPA series with lateral
connectors and
PEEK-pin/chuck



Three-axis prealigner
edge grip



Single-axis prealigner
LPA series with
bottom cable configuration

LPA Series

General

The LPA series prealigners are an innovative, high-precision, class 1 clean room solution with integrated scan electronics. These prealigners make it possible to align objects from 45 mm to 480 mm, regardless of their degree of transparency. They centre wafers, masks and other substrates, detect notches, flats or other marks and align the object exactly and independently. The prealigners are developed and produced by Logosol Inc. USA. isel Germany AG is the exclusive authorised distributor for Europe.

Features

Three-axis prealigner

- innovative all-in-one design
- Alignment times < 3.5 seconds
- repeatability:
linear 0.025 mm,
circular 0.02°
- contactless measurement using LED and CCD sensor
- integrated scanning electronics
- standalone capability
- Chuck or pin load and change to another wafer size without rebuild
- transparent, semi-transparent, holed and opaque wafers can be aligned
- SEMI, flat and notch wafer specifications
- For wafer sizes from 2" to 12"
- Connection fields available from the side and from below
- Optional: external (North sensor)
- Optional: Dual layer for bonded wafer

Features

Single-axis prealigner

- Alignment times < 2.5 seconds
- contactless measurement using LED and CCD sensor
- integrated scanning electronics
- Chuck load
- Change to another wafer size without rebuild
- transparent, semi-transparent, holed and opaque wafers can be aligned
- SEMI, flat and notch wafer specifications
- For wafer sizes from 3" to 12"
- Connection fields available at the side and from below

Prealigner

LPA Series

Characteristics

Specifications		Prealigner Model												Edge Handling Type
		Standalone						Embedded						
		26-3	38-3	58-3	312-3	812-3	1218-3	25-1E	38-1E	58-1E	312-1E	812-1E	1218-1E	
Wafer Diameter	2"	✓	-	-	-	-	-	✓	-	-	-	-	-	
	3"	✓	✓	-	✓	-	-	✓	✓	-	✓	-	-	
	100mm	✓	✓	-	✓	-	-	✓	✓	-	✓	-	-	4EH, 45EH
	125mm	✓	✓	✓	✓	-	-	✓	✓	✓	✓	-	-	5EH, 45EH, 56EH
	150mm	✓	✓	✓	✓	-	-	-	✓	✓	✓	-	-	6EH, 56EH
	200mm	-	✓	✓	✓	✓	-	-	✓	✓	✓	✓	-	8EH, 8ET
	300mm	-	-	-	✓	✓	✓	-	-	-	✓	✓	✓	12ET
	450mm	-	-	-	-	-	✓	-	-	-	-	-	✓	
Square Substrates		✓	✓	✓	✓	✓	✓	✓	✓	✓	✓	✓	✓	
Angular Accuracy (3 Sigma)	10 000 CPR Encoder	0.04°					N/A	0.06°					N/A	0.04°
	24 000 CPR Encoder	0.02°						0.04°						0.02°
Centering Accuracy (3 Sigma)		25 μm						50 μm						25 μm
Offset Limit	10 mm	12 mm					9 mm	10 mm					1.7 mm to 2.0 mm	
Body Dimensions	W	173 mm						95 mm						173 mm
	L	267 mm			317 mm		404 mm	266 mm				328 mm	267 mm or 317 mm	
	H	190 mm						191 mm						190 mm to 196 mm
Weight	5.0 kg to 5.7 kg						3.4 kg to 3.8 kg						5.3 kg to 6.0 kg	
Servo Axes	Three						One						Three	
Handling	Vacuum Chuck and Pins						Vacuum Chuck						Edge Handling	
Facilities Required	100-240V AC, 50-60 Hz, 48 V A or 24 V DC/2A, Vacuum 12" Hg for vacuum retention													
Host Interface	RS232, Ethernet													
Flat / Notch Compatibility	SEMI Standards Compliant													
Wafer Opacity	Transparent, Semi-Transparent and Opaque													
Cleanliness	Class 1													
MTBF	More than 70000 hours													

Accessories



Figure:: IMS-MDW1

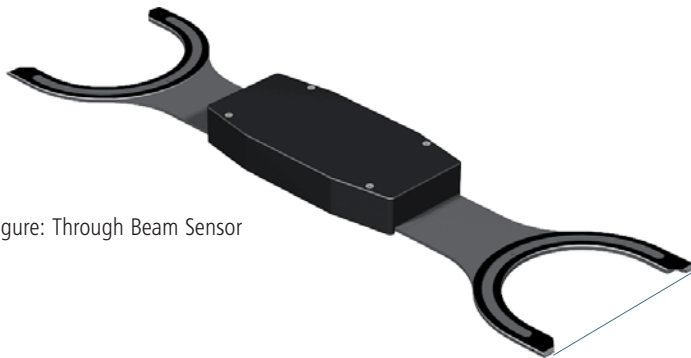

Figure: Through Beam Sensor



Figure: Flip module



Figure: Hand terminal IHT for standard controller



Figure: Teach Pendant for advanced controller

IMS-MDW1

- LED light source
- Measuring distance 45 mm (1,75")
- PNP / NPN switchable

Alignment on the fly (OTF)

- Wafer centering without prealigner
- Centralization during movement
- without separate alignment station

Through Beam Sensor

- optional to reflective Sensor
- integrated in End Effector

Flip module IFM-300-3

- Accurate flipping of wafers with the most precise positioning by means of
- positive stops
- Universal end effector adapter
- Mapping Sensor
- DC-Motor with transmission unit
- Electrical end-of-travel damping
- Continuously variable speeds

Hand terminal for Standard Controller

- Optimal support when teaching an isel wafer handler
- Keyboard layout optimized for isel wafer handlers
- Terminal function
- Teach function
- Diagnosis function
- RS-485
- Emergency button

Teach Pendant for Advanced Controller

- Optimal support when teaching an isel wafer handler
- graphical user interface on a 6.5"VGA color display
- ergonomic multi-grip for fatigue -free work
- Hand wheel for jogging operation
- Enable switch, key switch and stop button for safe manual operation (Complies iwth EN ISO 13850)

References

The following companies use successfully the products from iselRobotik:

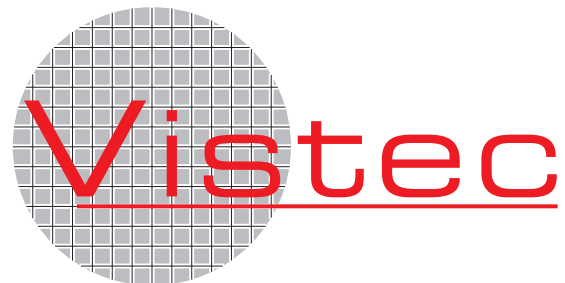

Space for your notes

Space for your notes

general

Space for your notes

Space for your notes

general

Index

A

Accessories (CNC machines)	E-22 – E-43
Accessories (LEZ linear units)	B-86
Accessories (linear guides)	B-28
Aluminium rotating plate	B-92, B-100
Aluminium slide IWS 1	B-25
Aluminium slide WS 1	B-6
Aluminium slide WS 3	B-8
Aluminium slide WS 4	B-18
Aluminium slide WS 6	B-16
Aluminium slide WS 7	B-18
Aluminium slide WS 8	B-20
Aluminium slide WS 11	B-12
Aluminium T-slot plate	B-92, B-100
Angle bracket	B-68 – B-70
Angular transmission	B-62

B

Ball nut spindles Ø 12 / 16 / 20 / 25 mm	B-34
Ball nuts	B-36 – B-38
Block diagram KG drives	B-32

C

CAN controller components	C-20
CAN I/O modules	C-20
CAN PCI board	C-19
CAN-CNC controller	C-26
Carbon brushes	E-32
Chassis (flatbed units)	E-20
Chuck assembly	B-92, B-94, B-96, B-98 B-100, B-102, B-104, B-107
Clamping blocks	B-37, E-32
Clamping nuts	E-32
Clutches	B-92

CNC control units iOP-19	C-14
Collet housings	B-102, B-104, B-107
Collets	E-42
Control PC iPC	C-18
Cooling/spray device	E-7
CoolMin	E-36
CoolMin tool cooling system	E-36
Critical rpm	B-52
Cross bench connection plates	B-66

D

Drive controller iMD	C-16
Drive dimensioning calculation	B-53
Drive elements overview	B-32
Drive modules	C-15
Dual track set	B-22

E

EC 42	C-6
EC 60	C-7
EC 86	C-8
End effectors	E-55
Energy guidance chain	B-71
Engraving spindle	E-32
EuroMod	E-12
Extraction device	E-34

F

Flange bearing	B-39
Flatbed unit FB2	E-20
FlatCom L	E-16
FlatCom M	E-14

Index

FlatCom XL E-18
 Frequency converter E-41

G

Gas pressure spring B-87
 Grease B-44

H

High frequency spindles HFS 800 / 2200 E-33
 Housing (flatbed units) E-20

I

iCC 10/20 C-19
 ICP 4030 E-6
 iCU-DC / iCU-EC C-24
 ICV 4030 E-8
 iLD 50-6 B-72
 iLM C-10
 iMC-S8 C-22
 iMD 10/20/40 C-16
 iMS C-12
 Installation set B-100
 iOP-19 C-14
 iPC 25 C-18
 iPU power unit C-25
 iPU-DC/iPU-EC C-25
 iSA 1500 E-25
 iSA 1500 L E-26
 iSA 1500 W E-30
 iSA 1500 WL E-29
 iSA 2200 E-28
 iSA 3600 E-29
 iSA 500 E-23
 iSA 750 E-24
 iSA 900 E-27

isy[®]CAM 2.8 D-4
 IT 116 Flash C-21

L

Length measurement sensor E-41
 LES 4 B-46
 LES 5 B-50
 LES 6 B-48
 LES combination examples B-54
 LES functional overview B-44
 LES motor modules B-56
 LEZ 1 B-76
 LEZ 1G Blue Line B-78
 LEZ 2 B-80
 LEZ 3 B-82
 LEZ 9 B-84
 LEZ angle bracket B-86
 LEZ combination examples B-87
 LEZ functional overview B-74
 LEZ motor modules B-77, B-79, B-81, B-83, B-85
 LFS-12-1 B-14
 LFS-12-10 B-22
 LFS-12-11 B-16
 LFS-12-2 B-18
 LFS-12-3 B-20
 LFS-16-120 B-24
 LFS-8-1 B-6
 LFS-8-2 B-6
 LFS-8-3 B-8
 LFS-8-4 B-10
 LFS-8-7 B-12
 Limit switches B-71
 Linear ball bearing B-28
 Linear guide slides function B-4
 Linear guides overview B-2
 Linear motors C-10
 Linear Track E-54
 Linear units overview B-42
 LSK Linear guides B-26

Index

M

Magnetic length measurement system	C-12
Magnetic rails MS	C-10
Magnetic tape	C-12
MC1-10 / MC 1-20 / MC 1-40	C-23
MD 1	B-102
MD 24/28	C-15
Motor fixing plate	B-86
Motor leads	B-61
Motor pin assignments	B-60, B-108
MS 135/200 HT - 2	C-4
MS 300/600/900 HT - 2	C-5
Multiple axis controller	C-22, C-24, C-25

O

Operating load calculation	B-29
OverHead Gantry	E-10

P

PAL-PC 2.1	D-7
Pillow blocks	B-40
Plastic nuts	B-35
Prealigners	E-56
ProNC	D-8

R

RDH-M	B-92
RDH-S	B-94
RDH-XS	B-96
Remote	D-6
RF 1	B-101
ROBOTICS	E-44
Rollers	B-15, B-28
Rotary tilting unit	B-98
Rotation units overview	B-88

S

Sensor	C-12
Servomotors	C-6 – C-8
Shaft housing blocks	B-15
Shaft slides	B-86
Single axis controller	C-21, C-23
SK 11/20/30	E-38, E-39, E-40
Sliding nuts	B-28, B-71
Slide plates	B-64 – B-65
Software and controller organisation	D-2
Spanner	D-14
Spindle motors	E-22 – E-31
Steel slide ILS 1	B-25
Steel slide LS 1	B-14
Step controller	C-21 – C-22
Suction device	E-6
Systems overview	E-2

T

Tailstock units	B-92, B-94, B-96, B-104
Tapped rails	B-28

Index

Tapped strips	B-71
T-slot slide plates	B-67
Tool changing stations	E-38 - E-40
Tool holders	E-42
Transmission shaft	B-62
Transport loads (rotation units)	B-109
Trolley LW 2	B-20
Trolley LW 3	B-14, B-18
Trolley LW 4	B-22
Trolley LW 5	B-16
Trolley LW 6	B-6
Trolley LW 7	B-8, B-10
Trolley LW 8	B-20
Trolley LW 10	B-22
Two-phase stepper motors	C-4, C-5

U

Uni-drill/mill motors UFM 500/UFM 1050	E-32
----------------------------------------	------

V

Vacuum clamping plates	E-43
Vacuum cleaning	E-41

W

Wafer handling robots	E-46 – E-51
Workspace lighting	E-7

Z

ZD 30	B-104
ZDS 2030	B-107
ZR 20	B-106

Area of application

1. The following conditions of sale shall apply to all goods delivery contracts concluded between the purchaser and ourselves. The ordering and acceptance of goods delivered by us shall constitute knowledge and/or confirmation of the customer's agreement with our conditions. These conditions shall apply to all future business relations, even where no further agreement has been expressly concluded. Any conflicting conditions on the part of the purchaser that have not been expressly acknowledged by us shall not be binding, even where we have made no express objection to them. Any such conflicting conditions are hereby expressly repudiated in advance. The following sales conditions shall also apply where we implement customer orders in the knowledge that conflicting or diverging conditions stipulated by the purchaser exist.

2. Any agreement, alteration or arrangement shall be made in writing.

3. Any agreements made between ourselves and the customer and relating to the purchasing contracts shall be confirmed in writing.

4. These General Terms and Conditions and the contractual relationship between our company and Seller shall be subject to the law of the Federal Republic of Germany; the international harmonised law, in particular the United Nations Convention on Contracts for the International Sale of Goods (CISG), shall be excluded.

5. In the case where Seller, in terms of the HGB (Handelsgesetzbuch – German Commercial Code), is a body corporate under public law or a public-law special fund, the exclusive place of jurisdiction – also on an international level – for all legal disputes resulting from this contractual relationship shall be at our registered office in Fulda. This shall be applicable accordingly in the case where Seller is an entrepreneur in terms of section 14 BGB (Bürgerliches Gesetzbuch – German Civil Code). However, we shall in each case have the right to institute legal proceedings at the place of fulfillment with respect to the delivery obligations on the basis of these General Terms and Conditions of Purchase and/or on the basis of prevailing individual agreements or at a general place of jurisdiction of Seller. Not affecting legal provisions, in particular those relating to exclusive competence, shall not be prevented by this.

Quotation and conclusion of contract

1. Purchasing contracts shall be concluded on the basis of a customer purchase order. The acceptance of a purchase order shall be confirmed either by the forwarding of an order confirmation document to the customer or by the delivery of the goods ordered, within a period of two weeks in both cases.

2. Our offers are subject to change and are non-binding, unless expressly stated otherwise. The scope of our responsibilities is established exclusively in our written order confirmation document.

3. Any drawings or illustrations included in our quotation or order confirmation documentation and any information issued with respect to weights or dimensions shall be understood as approximate, unless stated to the contrary.

4. All drawings, illustrations, calculations and other documents, materials, models, patterns and specifications are subject to property, copyright and other trade mark rights. These must be treated as confidential and may not be transferred to any third party without our written permission, irrespective of whether they are accompanied by any comment to that effect.

5. We accept no liability for any printing or calculation errors appearing in our literature or documentation and we shall entertain no claims for damages linked thereto.

6. We reserve the right to make any necessary changes in product construction, technical specifications and performance features, provided they constitute a technical improvement.

Prices and payment condition

1. Our prices are based on CIP clause of the Incoterms 2010 of the ICC (Carriage and Insurance paid to the agreed place of destination in accordance with Point V.1. of these Terms and Conditions) including standard packaging and excluding VAT. Our calculations are made on the day on which the invoice is issued and are shown on the invoice.

2. Delivery shall be made following advance payment of invoice in Euros.

3. All orders are based on the prices and price reductions valid at the time of delivery. Discounts shall only apply where they are expressly agreed in writing between ourselves and the purchaser. This is a written agreement, which shall also be shown in our order confirmation document.

4. Payment on delivery terms must be expressly agreed in advance. The purchase price is shown as net (with no deduction) with immediate payment by the purchaser following receipt of invoice, provided no other payment arrangements are shown in the order confirmation document. Payment is deemed to be fulfilled when we have access to the funds transferred. Payment by cheque is deemed to be fulfilled once the cheque is cleared and the funds have been transferred to us as credit. We are not bound to accept bills of exchange.

5. Legal provisions shall apply if a purchaser fails to pay on time.

6. All claims against the purchaser shall immediately become due if the purchaser fails to make a payment on time, breaches any other agreement made with us, or where we have reason to doubt his creditworthiness. We shall also be entitled in such cases to withhold any outstanding deliveries until such time as payment or satisfactory payment assurance has been received, even where agreement has been previously made to the contrary. Following the setting of an appropriate period, we shall also be entitled in such cases to withdraw from the contract and/or to seek damages due to non-fulfilment of contract. We shall also be entitled to waive the purchaser's right to dispose of any goods delivered and, subject to retention of title, to demand their return or transfer at the purchaser's expense and direct debit authorization shall be revoked.

7. The purchaser shall only be entitled to compensation, even where notification of defect or return claim has been made, where such claims are legally binding, are acknowledged by us or are undisputed. The purchaser shall only be entitled to withhold payment if his counter claims relate to the same contractual relationship.

Delivery and delivery terms

1. Delivery dates or periods shall be understood as non-binding provided no express agreement to the contrary has been made. The delivery times specified by us shall only commence once all relevant technical and implementation issues have been resolved.

2. The purchaser shall be obliged to implement all necessary requirements correctly and promptly. The agreed delivery period shall be extended - provided our rights have not been infringed by any purchaser payment arrears - by a period equal to the payment backlog that the purchaser has on the given (or any other) account. This shall also apply when a fixed delivery date has been agreed.

3. In the case of purchase contracts based on fixed date delivery as stipulated in Art. 286 Para. 2 No. 4 of the German Civil Code or Art. 376 of the German Commercial Code, we accept liability in accordance with current statutory provisions. The same shall apply where the purchaser, following delayed delivery for which we are responsible, is entitled to discontinue his interest in the further fulfilment of the contract. In this case, our liability shall be limited to foreseeable, typically-occurring damage. No liability limitations shall apply where delayed delivery is related to any breach of contractual conditions caused by our representatives or associates.

4. We also accept liability in accordance with current statutory provisions for any negligence in respect of contractual conditions caused by our representatives or agents. Where delayed delivery is not related to any breach of contractual conditions, our liability shall be limited to foreseeable, typically-occurring damage.

5. Where delayed delivery relates to a breach of contractual conditions caused by our representatives or agents, we accept liability in accordance with current statutory provisions, provided that compensation liability is restricted to foreseeable, typically-occurring damage.

6. In the event of delayed delivery for which we are responsible, the purchaser shall be entitled, for each full week of non-delivery, to a one-off compensation payment of 0.5% of the value of the delivery (valid to a maximum of 5 %).

7. We shall accept no additional liability for delay in delivery. Any further legal claims or purchaser rights above and beyond those relating to damage compensation and made in respect of delays in delivery for which we are responsible shall remain unaffected.

8. We shall be entitled to make partial delivery at any time, provided this is acceptable to the customer.

9. Delivery times are considered as fulfilled if the goods have been dispatched from our factory on time.

10. Under the onset of any conditions beyond our control, we shall be entitled to reschedule delivery or retire from any delivery contract, non-fulfilment notwithstanding. Conditions beyond our control shall be taken to mean strikes, lock-outs or any other conditions that hinder delivery or make delivery impossible, irrespective of whether the said conditions affect us directly or affect our suppliers. The purchaser shall be entitled to receive a declaration from us, as to whether we continue to deliver within a set period or retire from the delivery contract. In the absence of any such declaration, the purchaser shall be entitled to withdraw from the contract.

11. In the event of delays in acceptance on the part of the purchaser, we shall be entitled to claim compensation for any damage incurred and any additional expenditure. The same shall apply where the purchaser culpably infringes any obligation to cooperate. In the event of delays in acceptance and debtor default, the risk of accidental deterioration or loss of the goods shall transfer to the purchaser.

Transfer of risk - shipment/packaging - delivery

1. If delivery is made under clause CIP according to Incoterm 2010 the ICC, then:
-- Standard deliveries nationally and Community countries to agreed delivery address (destination)
-- Standard deliveries to third countries to import-seaport as agreed destination

We reserve the right to make a surcharge for express shipment and shipment by air.

Airfreight to third countries is still with costs. For parts with oversize length from 6m, with 2.4m and height 2.4m including packaging, delivery shall be by express air freight.

2. The risk is transferred to the customer with the delivery of the goods to the first forwarding agent or carrier, at the latest however on leaving the factory or warehouse.

3. With regard to deliveries involving goods to be installed or assembled at the purchaser's premises, risk shall transfer on the day on which the goods are commissioned into use, or at the end of a given trial period where the said period has been agreed beforehand. In the event of any delay occurring during shipment or delivery to the purchaser, any delay in the commencement or implementation of installation or assembly, any delay in commissioning or testing at the purchaser's premises or, where any delay occurs for whatever reason in the acceptance of the goods by the purchaser, risk shall be considered to have already transferred to the purchaser at the moment the goods were made available to him.

4. In accordance with packaging regulations and with the exception of pallets, we will not

accept the return of any packaging used for transportation or any other purpose. The purchaser shall be responsible for the proper disposal of any packaging delivered.

5. Where shipment is delayed at the request of the purchaser, or occurs due to his negligence, any subsequent warehousing costs and risks shall be the responsibility of the purchaser. The same shall apply in the case of notification of readiness for shipment.

6. With regard to the delivery of customer orders, the minimum order values shall be 100 EUR/OS (domestic) and 250 EUR/OS (abroad). These costs do not include VAT. The preparation costs for small deliveries below the minimum value for delivery within Germany shall be 50 EUR/OS (excluding VAT). These costs do not include postage and packing. We are unable to ship orders below the above-stated minimum value to addresses outside Germany.

7. Special orders, including goods ordered in quantities or with dimensions not stated in our catalogue, must be made in writing by the purchaser. Such orders may be subject to an agreed advance payment. Where one-off production orders in very large quantities are accepted by us, we reserve the right to deliver the goods with an appropriate quantity margin (normally ±10%). Packaging charges are, as a general rule, calculated in accordance with manufacturing costs.

Guarantee / liability

1. In contractual relationships with registered traders, we guarantee our products defect free for a period of one year from arriving at the place of destination in accordance with V.1 of these Terms.

2. Milling spindles and other consumables are guaranteed defect free for a period of 6 months. This 6-month guarantee period also applies to milling spindles already integrated into machine systems.

3. The technical advice we give is based on the best of our knowledge. However, we accept no liability for any information relating to the suitability and application of our goods and the purchaser is not exempt from the responsibility of conducting his own calculations, tests and trials. The purchaser shall be solely responsible for complying with any statutory provisions and regulations applying to the use of the goods. Liability with regard to the suitability of our goods for any given application shall only be accepted where previously expressed in writing.

4. We accept liability for material defects, excluding any further claims - subject to the following provisions and those given under VIII. and IX. - as follows:

5. Any claims relating to defects submitted by the purchaser as registered trader shall only be upheld if the purchaser has properly carried out the necessary inspection and has fulfilled notification obligations in accordance with Article 377 of the German Commercial Code. Other purchasers shall forward their complaints to us in writing within 10 days of receipt of the goods. With regard to business with non-trade personnel, this shall only apply where the defects are apparent. Complaints shall only be considered where the goods are still in "as delivered" condition.

6. With regard to justified complaints relating to defects we shall be entitled, in excluding purchaser rights, to withdraw from this contract, to raise the sales price or to honour our supplementary performance obligations unless, in accordance with statutory provisions, we are justified in refusing to honour our supplementary performance obligations. The purchaser shall allow us a reasonable period in which to provide supplementary performance. With regard to supplementary performance, we shall be entitled to choose whether to correct the defect (rectification) or deliver replacement goods. If we choose to correct the defect, we shall bear any costs (provided these do not increase) incurred due to the object of agreement being located at a location other than the delivery address. In the event of our failure to provide this supplementary performance, the purchaser shall be entitled to choose either a reduction in the purchase price or withdrawal from the contract. Supplementary performance is deemed to have failed following a second unsuccessful attempt, unless further supplementary performance attempts are appropriate and acceptable to the purchaser on the basis of the object of agreement. Claims for damage compensation under the following conditions and with regard to defects may only be issued by the purchaser after supplementary performance is deemed to have failed. The purchaser's right to claim damage compensation shall remain unaffected under the following conditions.

7. Goods may only be returned to us with our consent. Goods shall be returned in their original packaging or in packaging of similar value. The purchaser shall bear the full costs of shipment. Compensation shall only be made where the defect complaint is deemed justified. Where the customer allows us to test the goods and a defect is discovered, we accept liability, where no defect is found, we shall be entitled to issue a charge for each component tested.

8. Warranty claims may only be lodged by the purchaser up to one year after the goods are delivered, except in the case where we have knowingly hidden the fault, whereby statutory provisions shall apply. Our responsibilities, as stipulated in Section VI, 9 and Section VI, 10 shall in this case remain unaffected.

9. We are required in accordance with current legal provisions to accept the return of new goods delivered or to reduce the purchase price without the setting of any requisite period if the purchaser's customer, as the end user of the new goods (sale of consumer goods), demands the return of the goods or a price reduction from the purchaser due to a defect or asserts a claim for recourse against the purchaser. In this case, we shall also be liable for compensating the purchaser's expenses, including transportation, material, labour and material, including interest, to the end user due to the replacement of the defective goods on the basis of transfer of risk from us to the purchaser. No claim made by the purchaser with regard to defect shall be supported, where the purchaser has failed to carry out the inspection and to fulfil notification obligations in accordance with Article 377 of the German Commercial Code.

10. No liability under Section VI, 9 shall be accepted where the defect relates to any advertising slogan or any contractual agreements not originating with us, or where the purchaser himself affords the end user any special guarantees. Liability shall also be denied where, based on statutory provisions, the purchaser himself has no warranty obligations in respect of the end user or where the complaints have not been made in respect of any claim made by him. The above shall also apply, where the purchaser has afforded the end user guarantees above and beyond the legal limit.

11. We shall be liable, independent of the following liability limitations and in accordance with the statutory provisions covering loss of life, bodily injury and damage to health caused by the deliberate or negligent actions of ourselves, our legal representatives or our agents, as well as for any damage covered by the German Product Liability Act. We shall be liable in accordance with statutory provisions for any damage not included in Clause 1 caused by the deliberate act, gross negligence or due to any breach of contract committed by us, our legal representatives or our agents. In this case, compensation liability shall be limited to foreseeable, typically-occurring damage, in so far as we, our legal representatives and our agents are not deemed to have acted wilfully. We shall also be liable in the context of this warranty and in respect of the goods or their components for the properties and/or life span guarantees we have given. We shall only be liable for damage relating to defects affecting the guaranteed quality of life span, but not directly relating to the goods themselves, where the risk of such damage is apparent from the quality and life span warranty.

12. No further liability will be accepted without examination of the claims made; this shall apply in particular to tort claims or claims for the compensation of wasted expenses in lieu of performance; our liability as stipulated in Section IV, 6 - Section 6, 10 of this contract shall remain unaffected. Where our liability is limited or excluded, the same shall also apply to that of our employees, sub-contractors, representatives and agents.

13. Purchaser claims for defect damage compensation shall lapse one year after initial delivery of the goods. This shall not apply where we, our legal representatives or our agents are responsible for loss of life, bodily injury or damage to health or where we or our legal representatives have acted wilfully or negligently, or where our vicarious agents have acted wilfully.

14. In general, we accept no liability for any damage resulting from the following: incorrect or inappropriate use or storage, faulty installation by the customer or by any third party, damage resulting from the customer's own attempts at servicing or modification, natural instances of wear, faulty or negligent handling, chemical attack, electrical faults, etc. over which we have no control, or damage resulting from improper use or the failure to comply with operating instructions or information sheets. Furthermore, our warranty conditions shall not apply where the customer or a third party makes any modification without prior written approval from us and without justification (relate to controls on our part in the removal of defects), especially where such modifications relate to control / software and even where the fault appears in an unmodified component.

15. In the event that use of the delivered goods infringes German Copyright or Trade Mark Law, we will bear the costs of either providing the customer with the respective rights or of modifying the goods in a way acceptable to the customer, such that no further breach of copyright law exists. Where it is not possible to restore appropriate commercial conditions within an acceptable period, the customer shall be entitled to withdraw from the contract. Under these conditions, we also reserve the right to withdraw from the contract. In addition thereto, we will exempt the customer from any incontestable or legally established claims.

16. Our acceptance of liability shall be subject to current statutory provisions governing liability for infringements of copyright and trade mark law. Any liability under Article 15 shall only be accepted by us provided the customer immediately notifies us of the infringement of any copyright or trade mark law, provided he supports us to a reasonable extent in the defence of any claims made or allows us to make any relevant modification, provided all defensive measures, including extra-judicial provisions, are available to us, provided not based on the customer's instruction and where there has been no breach of the law and provided the customer has made no modification to the delivered goods or used them in any way contrary to the provisions of the contract.

Repairs and the return of goods

1. When requested, the purchaser shall be provided with cost estimates prior to any repair being undertaken. Our liability relating to shipment and packaging shall be borne by the purchaser. Invoices for repair work shall be paid in full, with no deductions and immediately upon receipt. All repairs, including those made under warranty shall, under normal circumstances, be carried out in our repair facility, unless agreed to the contrary in writing.

2. Delivered goods will only be taken back with our consent and once any relevant fees have been agreed. Under normal circumstances, we will not accept the return of any specially-prepared goods or software!

Goods dispatched or returned must always be accompanied by delivery documents or copies of invoice. The costs of returning goods shall be borne by the purchaser under "free to door" conditions.

Assembly

1. Installation work will be charged separately unless agreed to the contrary in writing. Installation costs shall include travel costs and accommodation allowances, as well as the normal rates of payment for the work including supplements for overtime, night work, work carried out on Sundays and holidays and work carried out under difficult conditions, as well as for planning and commissioning.

2. We shall invoice for all costs incurred in respect of preparatory work, travel, waiting times and commissioning time. The customer shall compensate us for any further waiting time, travelling time and travelling costs incurred due to any delay in the starting or final commissioning of the said works, where the causes of such delays are beyond our control.

3. The customer shall bear all costs relating to the provision of any necessary auxiliary personnel and shall ensure that any tools needed are available in the required quantities. The customer shall also ensure the provision of suitably-sized, dry premises for the storage of machinery parts, apparatus, materials, tools, etc. The customer shall take appropriate measures to protect our property and that of our service personnel, equal to those he would take for the protection of his own property. Where the customer's operating conditions require the use of special clothing or protective equipment, he shall ensure that these are made available to our service personnel.

4. Our service personnel and auxiliary staff shall not be required to undertake any tasks not directly related to the implementation of our delivery and installation duties, unless prior agreement has been reached with us. Where such tasks are agreed, we accept no liability for any works implemented by our personnel beyond the scope of our contractual responsibilities. Any installation works carried out by the customer, or by any third party commissioned by him, must meet our current operating and installation requirements.

Software, software use and additional guarantee and defect claims

1. With regard to any software supplied by us and all documentation belonging thereto, the customer shall be provided, in return for payment, with a non-expiring, non-exclusive, non-transferable user rights on an established or, in certain cases, yet to be specified hardware product. We shall remain the owner of the copyright and all associated trade marks. Any entitlement to produce copies shall be granted solely for the purposes of securing data. Copyright infringement must not be removed.

2. Instructions for installation and commissioning shall be supplied by us in a printed format together with safety advice relating to your format. All other documentation shall be supplied exclusively by us, in a software data format. Following the release of new software, all necessary software data relevant to the release will be sent together with the new software. Furthermore, we reserve the right to deliver such documentation in the form of online help or online documentation.

3. Transfer to any third party may only be effected subject to our prior written consent. Acknowledgement of this condition must be obtained prior to the transfer of software to a third party. No modification shall be permitted.

4. Each and every infringement of these provisions shall be subject to a penalty amounting to 10 times the total value of the customer order. Any entitlement to further claims for compensation shall remain unaffected. Contractual penalties shall be levied separately and in addition to any potential further claims for damage compensation. The customer shall be entitled to provide evidence in support of any claim of reduced or negligible damage. The software and all documentation belonging thereto shall, in this case, be returned to us.

5. These conditions shall not apply to exclusive, customer-specific software developed and provided to meet individual customer requirements. Under the contract-related provision of control software, developed by us using modular multi-application software components (standard software modules), these are to be fitted and adapted in accordance with customer-specific and contractual performance requirements (customer-specific applications program).

6. On payment of the full purchase price for the customer-specific application program, we shall provide the customer with exclusive, spatially- and temporally-unrestricted user rights. The customer will not be afforded any rights with regard to the standard software module on which the customer-specific adaptations are based, irrespective of the type of module.

7. We shall be entitled, irrespective of these provisions and on the basis of other customer orders, to prepare and offer for sale the resulting customer-specific software solutions developed. We shall in each and every case retain non-exclusive user rights to customer-specific solutions for internal operational purposes.

8. Subject to the provisions above, we undertake the guarantee for the correct duplication of our software. Our software may be used for up to run on hardware products specified by us. Our warranty obligations shall be fulfilled through the delivery of replacement parts. We undertake no guarantee for the fault-free operation of the software or its data structure, unless we have agreed to the contrary in writing. Regarding customer-specific software, we guarantee compliance with the specific function and performance features outlined in the operational specifications, the order confirmation document and the established function / operating sequence documentation. We accept no liability for the fault-free functioning of programs in all the customer's planned applications and, in particular, with regard to any applications not mentioned or tested at the time of program creation / acceptance.

Retention of title

1. The goods delivered (goods subject to the retention of title) shall remain our property until such time as all debts, including all current account balance claims, accrued by the purchaser to us, and any other claims, have been paid in full. In the event of any infringement of contractual conditions on the part of the purchaser, e.g. payment arrears, we shall be entitled, after setting and upon culmination of a reasonable period, to repossess goods subject to the retention of title. The repossession of goods subject to the retention of title shall constitute our withdrawal from the contract. The seizure of goods subject to the retention of title by us shall constitute our withdrawal from the contract. Following repossession, we shall be entitled to dispose of goods subject to the retention of title. Following the deduction of an appropriate amount for the costs of the disposal, the proceeds from the disposal shall be deducted from the outstanding amounts owed to us by the purchaser.

2. The purchaser shall be responsible for the proper handling of goods subject to the retention of title and shall insure these at his own expense to their full value against damage by fire, water and theft. The costs of its inspection and servicing the goods at their appropriate intervals shall be borne by the purchaser.

3. The purchaser shall be entitled to use and/or dispose of goods subject to the retention of title in the course of his normal business activities, provided he is not in payment arrears. Pawning or chattel mortgaging shall not be permitted. Any existing claims (including all current account balance claims) with respect to goods subject to the retention of title arising due to resale or for other legal reasons (insurance, tort) shall be assigned by the purchaser by way of security and in their entirety to us; we hereby accept assignment. The purchaser has our (revocable) authorisation to collect the claims assigned to us for his invoices in his own name. We reserve the right to revoke authorisation at any time, should the purchaser not be able to meet his payment obligations. The purchaser shall not be entitled to assign the claim even for the purposes of collecting the debts by way of factoring, unless an obligation is simultaneously imposed on the factor to transfer the collected amounts directly to us, provided we still have outstanding claims against the purchaser.

4. Any processing or modification of goods subject to the retention of title shall be carried out on our behalf. Where goods subject to the retention of title are modified using items not belonging to us, we shall become co-owners of the new commodity in the ratio of the value of the goods subject to the retention of title (total amount of invoice including VAT) to the other items used, at the time of modification. The same shall apply to the processing of new products created as applies to goods subject to the retention of title. In the case of an inseparable mix of goods subject to retention of title and items not belonging to us, we shall become co-owners of the new commodity in the ratio of the value of the goods subject to retention of title (total amount of invoice including VAT) to the other items used, at the time of creation of the mix. Where the purchaser's item is the major component of the mix, the purchaser shall agree to assign co-ownership to us on a proportional basis; we hereby accept the assignment. The purchaser shall ensure that a record of sole- and co-ownership on a single item is kept on our behalf.

5. Where a third party gains access to goods subject to retention of title and in particular to pledged goods, the purchaser shall provide notification of our ownership and shall notify us immediately if he knows or should know that his ownership is infringed. Where the third party is unable to compensate us for the in-court and out-of-court costs incurred in respect thereof, liability shall fall to the purchaser.

6. We undertake to release the securities due to us in so far as their value exceeds the claims to be secured by more than 10%, the choice being ours as to which securities to release.

Applicable law, court of jurisdiction and location

1. All legal relationships between the parties are exclusively subject to German law, to the exclusion of the United Nations Convention on Contracts for the International Sales of Goods, even if the buyer has its usual place of residence or abode abroad or delivery is being made abroad. The same applies if the buyer transfers their usual residence to another country at a later time or is unavailable.

2. If you do not have a place of residency in Germany at the time of ordering or you move your place of residency to another country following the conclusion of the contract or your place of residency is not known at the time that a claim is made, legal jurisdiction for all disputes arising from and in relation to the contractual relationship is Fulda.

3. If the customer is a merchant under the provisions of paragraph 1 section 1 of the Commercial Code (Handelsgesetzbuch, HGB), a legal person under public law or a special fund under public law, the courts in Fulda will be exclusively responsible for all disputes arising from or in connection with the relevant contractual relationship. In all other cases the customer and we are permitted to bring claims before any court that is legally cognisant.

4. Should individual provisions of this contract be wholly or partly invalid or void then the validity of the rest of the contract will not be affected. The parties undertake to replace the invalid or void provision with a valid provision that is closest to the intended commercial purpose. The same applies in cases of gaps. Changes and amendments to these General Conditions must be agreed in writing. The suspension of this requirement of the written form must also be made in writing.

This contract is executed both in German and in English. In the case of differences between the German and the English version, as well as in the case of legal disputes, the German version shall exclusively be applicable. The parties expressly waive a translation into any other language.

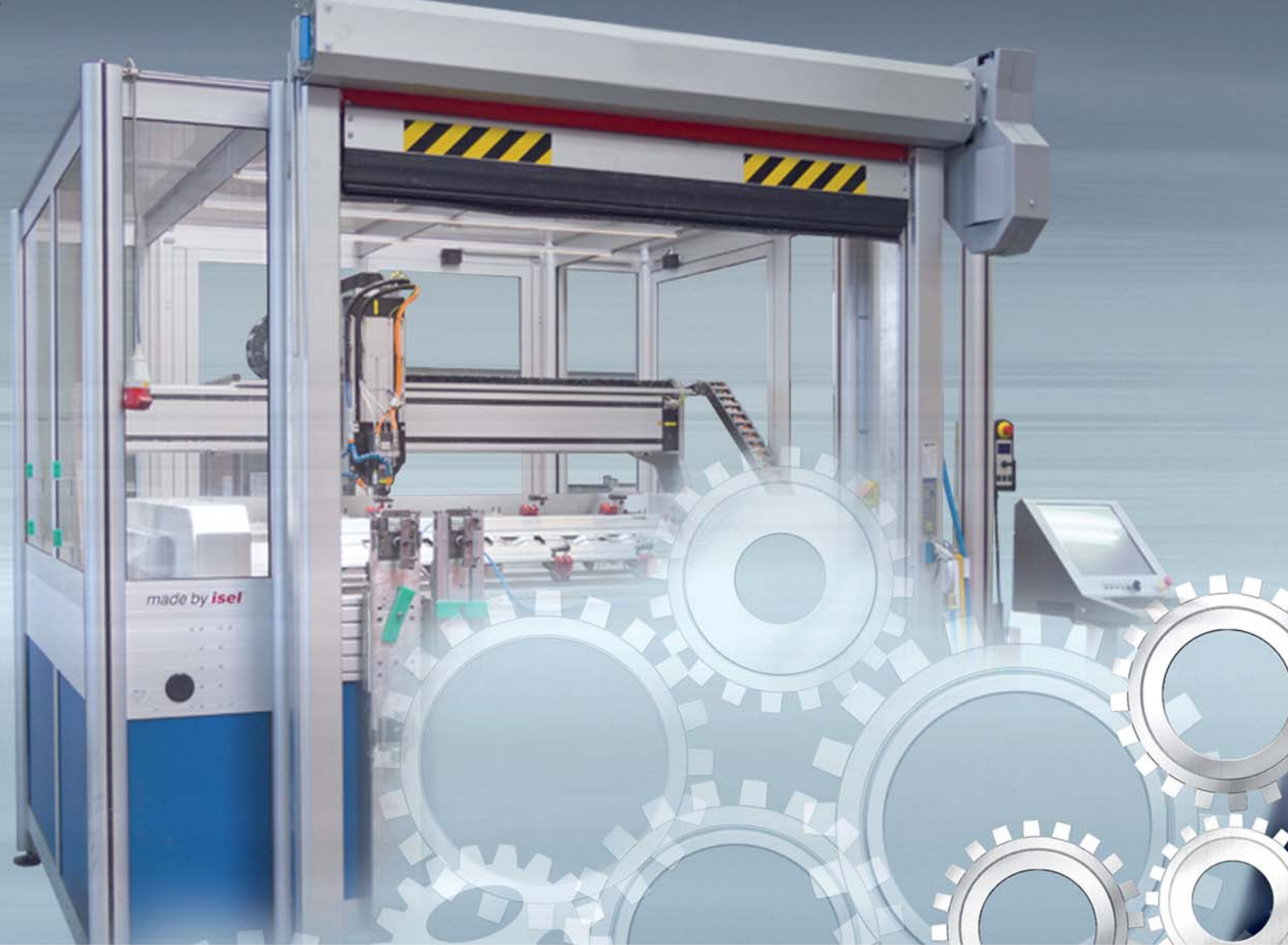

...for best quality and price...

isel Germany AG

Buergermeister-Ebert-Str. 40
D-36124 Eichenzell
Phone: +49 (0) 6659 / 981-700
Fax: +49 (0) 6659 / 981-776
E-Mail: automation@isel.com
www.isel.com/germany

isel France

ZAC de la Prévauté
4, Rue des Côtes d'Orval BP 41
F-78550 Houdan
Phone: +33 (0) 130 461 201
E-Mail: info@isel.fr
www.isel.com/fr

isel UK Ltd.

Unit 17 | Maylands Business Centre
Redbourn Road
Hemel Hempstead | HP2 7ES | United Kingdom
Phone: +44 (0) 1442 531 225
E-Mail: info@isel-uk.com
www.isel.com/uk

isel Austria GmbH & Co.KG

Maria Theresia-Str. 53 / 1.1
4600 Wels / Austria
Phone: +43 (0) 7242 206829
Fax: +43 (0) 7242 211445
E-Mail: info@isel-austria.com
www.isel.com/at

isel Hungaria Kft.

József A. utca 38
H-8200 Veszprém
Phone: +36 (0) 88 406 682
Fax: +36 (0) 88 406 681
E-Mail: iselhungaria@isel.hu
www.isel.com/hu

isel USA, Inc.

69 Bloomingdale Road
USA, Hicksville, New York 11801
Phone: 001-516-595-7497
E-Mail: George.Klein@isel.com
Joseph.Griffin@isel.com
www.techno-isel.com